

# HITACHI

**ZW180-7 | ZW180PL-7** | Preliminary  
ZW-7 series

Reliable solutions



## ZW180

### WHEEL LOADER

Model code: ZW180-7 | ZW180PL-7

Engine maximum power: 173 hp (129 kW)

Operating weight: 32,959–34,635 lb. (14,950–15,710 kg)

Bucket capacity: 3.3–6.8 yd<sup>3</sup> (2.5–5.2 m<sup>3</sup>)

\* Shown with optional equipment that may not be available in all markets

# SPECIFICATIONS

ENGINE	
Model	CUMMINS B6.7
Type	4 cycle water-cooled, direct injection
Aspiration	Turbocharger and intercooled
Aftertreatment	DPF+SCR system
No. of cylinders	6
Maximum power	
ECE R120 gross	173 hp (129 kW) at 2,200 min <sup>-1</sup> (rpm)
ISO 9249: 2007 net	168 hp (125 kW) at 2,200 min <sup>-1</sup> (rpm)
Rated power	
ISO 14396: 2002 gross	173 hp (129 kW) at 2,200 min <sup>-1</sup> (rpm)
ISO 9249: 2007 net	168 hp (125 kW) at 2,200 min <sup>-1</sup> (rpm)
Maximum torque	
ISO 9249: 2007 net.....	1,104 Nm at 1,100 min <sup>-1</sup> (rpm)
gross .....	1,120 Nm at 1,100 min <sup>-1</sup> (rpm)
Bore and stroke	4.2" x 4.9" (107 mm X 124 mm)
Piston displacement	410.1 cu.in (6.69 L)
Batteries	2 x 12 V
Air cleaner	Two element dry type with restriction indicator

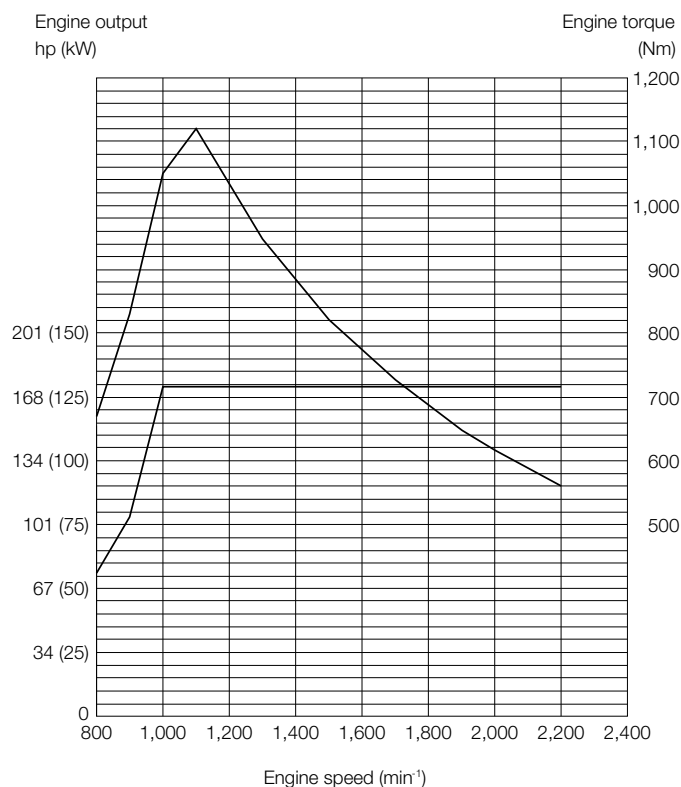

POWER TRAIN	
Transmission	Torque converter, countershaft type power-shift with computer-controlled automatic shift and manual shift features included.
Torque converter	Three elements, single stage, single phase
Main clutch	Wet hydraulic, multi-disc type
Cooling method	Forced circulation type
Travel speed* Forward/Reverse	
1st	3.7/3.9 mph (5.9/6.2 km/h) [3.9/4.1 mph (6.3/6.6 km/h)]
2nd	7.1/7.5 mph (11.5/12.1 km/h) [7.6/8.0 mph (12.2/12.9 km/h)]
3rd	10.9/16.5 mph (17.5/26.5 km/h) [11.5/17.6 mph (18.5/28.3 km/h)]
4th	15.7 mph (25.3 km/h) [16.8 mph (27 km/h)]
5th	24.2 mph (39 km/h) [24.2 mph (39 km/h)]

\*With 20.5 R25 (L3) tires  
[: Data at Power Mode

AXLE AND FINAL DRIVE	
Drive system	Four-wheel drive system
Front and rear axle	Semi-floating
Front	Fixed to the front frame
Rear	Trunnion support
Reduction and differential gear	Two stage reduction with limited slip differential
Oscillation angle	Total 20° (+10°, -10°)
Final drives	Heavy-duty planetary, mounted inboard

TIRES	
Tire size	20.5R25 (L3)

BRAKES	
Service brakes	Inboard mounted fully hydraulic 4 wheel wet disc brakes. Front and rear independent brake circuit
Parking brakes	Spring applied, hydraulically released, dry disc type with external output shaft

STEERING SYSTEM	
Type	Articulated frame steering
Steering angle	Each direction 40°; total 80°
Cylinders	Double-acting piston type
No. x Bore x Stroke	2 x 2.8" x 17.4" (2 x 70 mm x 442 mm)

HYDRAULIC SYSTEM	
<b>Arm and bucket are controlled by multifunction lever</b>	
Arm controls	Four position valve; Raise, hold, lower, float
<b>Bucket controls with automatic bucket return-to-dig control</b>	
Three position valve; Roll back, hold, dump	
<b>Main pump (Serve as steering pump)</b>	
Variable Displacement Axial Plunger Pump	
Maximum flow	59.1 gal (224 L) /min at 2,200 min <sup>-1</sup> (rpm)
Maximum pressure	3,974 psi (27.4 MPa)
<b>Fan pump</b>	
Fixed Displacement Gear Pump	
Maximum flow	14.5 gal (54.8 L) /min at 2,200 min <sup>-1</sup> (rpm)
Maximum pressure	2,640 psi (18.2 MPa)
<b>Hydraulic cylinders</b>	
ZW180-7	
Type	Double acting type
No. x Bore x Stroke	Arm: 2 x 4.9" x 30.1" (2 x 125 mm x 765 mm)
	Bucket: 1 x 5.9" x 19.5" (1 x 150 mm x 495 mm)
Filters	Full-flow 15 micron return filter in reservoir
ZW180PL-7	
Type	Double acting type
No. x Bore x Stroke	Arm: 2 x 4.9" x 30.1" (2 x 125 mm x 765 mm)
	Bucket: 2 x 4.3" x 37.6" (2 x 110 mm x 955 mm)
Filters	Full-flow 15 micron return filter in reservoir
<b>Hydraulic cycle times</b>	
ZW180-7	
Lift arm raise	5.3 s
Lift arm lower	3.7 s
Bucket dump	1.1 s
Total	10.1 s
ZW180PL-7	
Lift arm raise	5.3 s
Lift arm lower	3.7 s
Bucket dump	2.3 s
Total	11.3 s

\*Data at Power Mode

ENVIRONMENT	
<b>Engine Emissions</b>	
EPA Final Tier 4/EU stage V	
<b>Sound level</b>	
Sound level in cabin according to ISO 6396: 2008	67 LpA dB(A)
External sound level according to ISO 6395: 2008 and EU Directive 2000/14/EC	104 LwA dB(A)

SERVICE REFILL CAPACITIES	
Fuel tank	60.7 gal (230 L)
Engine coolant	6.6 gal (25 L)
Engine oil	6.6 gal (25 L)
Torque converter and transmission	7.9 gal (30 L)
Front axle differential and wheel hubs	8.2 gal (31 L)
Rear axle differential and wheel hubs	9.0 gal (34 L)
Hydraulic oil tank	26.4 gal (100 L)
DEF/AdBlue® tank	6.6 gal (25 L)

# SPECIFICATIONS

## DIMENSIONS AND SPECIFICATIONS ZW180-7

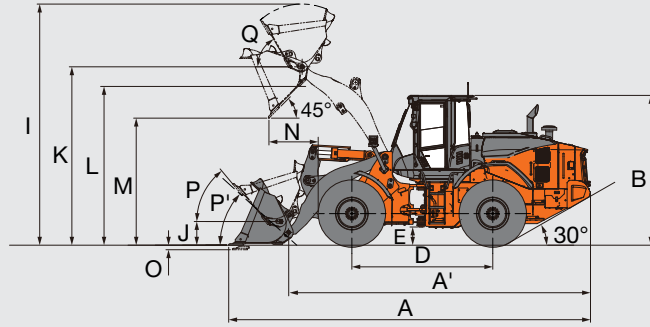
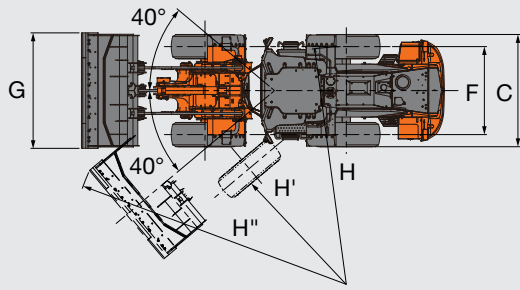

Bucket type			Standard arm				High-lift arm		
			General purpose				High volume	General purpose	
			Weld-on teeth	Bolt-on cutting edge	Weld-on teeth	Bolt-on cutting edge	Bolt-on cutting edge	Weld-on teeth	Bolt-on cutting edge
Bucket capacity	ISO 7546: 1983 Heaped	yd <sup>3</sup> (m <sup>3</sup> )	3.4 (2.6)	3.4 (2.6)	3.7 (2.8)	3.7 (2.8)	6.8 (5.2)	3.4 (2.6)	3.7 (2.8)
	ISO 7546: 1983 Struck	yd <sup>3</sup> (m <sup>3</sup> )	2.9 (2.2)	2.9 (2.2)	3.1 (2.4)	3.1 (2.4)	5.8 (4.4)	2.9 (2.2)	3.1 (2.4)
A	Overall length	ft-in (mm)	26' 6" (8,085)	26' 2" (7, 975)	26' 8" (8,135)	26' 4" (8,025)	27' 8" (8,430)	27' 9" (8,470)	27' 11" (8,520)
A'	Overall length (without bucket)	ft-in (mm)	22' 1" (6,725)	22' 1" (6,725)	22' 1" (6,725)	22' 1" (6,725)	22' 1" (6,725)	23' 8" (7,225)	23' 8" (7,225)
B	Overall height up to cab top	ft-in (mm)	10' 10" (3,310)	10' 10" (3,310)	10' 10" (3,310)	10' 10" (3,310)	10' 10" (3,310)	10' 10" (3,310)	10' 10" (3,310)
C	Width over tires outside tire	ft-in (mm)	8' 3" (2,505)	8' 3" (2,505)	8' 3" (2,505)	8' 3" (2,505)	8' 3" (2,505)	8' 3" (2,505)	8' 3" (2,505)
D	Wheel base	ft-in (mm)	10' 2" (3,100)	10' 2" (3,100)	10' 2" (3,100)	10' 2" (3,100)	10' 2" (3,100)	10' 2" (3,100)	10' 2" (3,100)
E	Ground clearance Minimum	ft-in (mm)	1' 4" (400)	1' 4" (400)	1' 4" (400)	1' 4" (400)	1' 4" (400)	1' 4" (400)	1' 4" (400)
F	Tread	ft-in (mm)	6' 4" (1,930)	6' 4" (1,930)	6' 4" (1,930)	6' 4" (1,930)	6' 4" (1,930)	6' 4" (1,930)	6' 4" (1,930)
G	Bucket width	ft-in (mm)	8' 4" (2,535)	8' 4" (2,535)	8' 4" (2,535)	8' 4" (2,535)	9' 8" (2,950)	8' 4" (2,535)	8' 4" (2,535)
H	Turning radius (centerline of outside tire)	ft-in (mm)	17' 2" (5,235)	17' 2" (5,235)	17' 2" (5,235)	17' 2" (5,235)	17' 2" (5,235)	17' 2" (5,235)	17' 2" (5,235)
H'	Turning radius to inside of tires	ft-in (mm)	9' 10" (2,995)	9' 10" (2,995)	9' 10" (2,995)	9' 10" (2,995)	9' 10" (2,995)	9' 10" (2,995)	9' 10" (2,995)
H''	Loader clearance radius, bucket in carry position	ft-in (mm)	20' 2" (6,145)	20' 1" (6,115)	20' 3" (6,160)	20' 1" (6,130)	21' 1" (6,420)	20' 9" (6,330)	20' 10" (6,345)
I	Overall operating height bucket full raise	ft-in (mm)	17' 4" (5,280)	17' 4" (5,280)	17' 6" (5,345)	17' 6" (5,345)	19' 2" (5,840)	18' 8" (5,685)	18' 10" (5,750)
J	Carry height of bucket pin at carry position	ft-in (mm)	1' 4" (400)	1' 4" (400)	1' 4" (400)	1' 4" (400)	1' 4" (400)	1' 4" (400)	1' 4" (400)
K	Height to bucket hinge pin, fully raised	ft-in (mm)	12' 11" (3,925)	12' 11" (3,925)	12' 11" (3,925)	12' 11" (3,925)	12' 11" (3,925)	14' 3" (4,335)	14' 3" (4,335)
L	Lift arm clearance at max lift	ft-in (mm)	12' 0" (3,670)	11' 12" (3,645)	12' 0" (3,670)	11' 12" (3,645)	11' 12" (3,650)	13' 4" (4,055)	13' 4" (4,055)
M	Dumping clearance 45 degree, full height	ft-in (mm)	8' 11" (2,710)	9' 2" (2,785)	8' 9" (2,675)	9' 0" (2,750)	8' 1" (2,465)	10' 6" (3,190)	10' 4" (3,155)
N	Reach, 45 degree dump, full height	ft-in (mm)	3' 11" (1,205)	3' 7" (1,095)	4' 1" (1,240)	3' 8" (1,130)	4' 8" (1,415)	4' 1" (1,245)	4' 2" (1,280)
O	Digging depth (horizontal digging angle)	ft-in (mm)	0' 3" (70)	0' 4" (95)	0' 3" (70)	0' 4" (95)	0' 4" (95)	0' 7" (170)	0' 7" (170)
P	Max. roll back at carry position	deg	47	47	47	47	47	47	47
P'	Max. roll back at ground level	deg	43	44	43	44	44	45	45
Q	Roll back angle at full height	deg	60	60	60	60	60	53	53

Bucket type		Standard arm					High-lift arm	
		General purpose				High volume	General purpose	
		Weld-on teeth	Bolt-on cutting edge	Weld-on teeth	Bolt-on cutting edge	Bolt-on cutting edge	Weld-on teeth	Bolt-on cutting edge
Static tipping load ISO 14397-1: 2007 (Section 1-5) *	Straight .....lb (kg)	27,712 (12,570)	27,426 (12,440)	27,712 (12,570)	27,448 (12,450)	26,544 (12,040)	21,583 (9,790)	21,561 (9,780)
	Full turn .....lb (kg)	23,986 (10,880)	23,700 (10,750)	23,964 (10,870)	23,700 (10,750)	22,774 (10,330)	18,541 (8,410)	18,519 (8,400)
Breakout force	.....kN	128	117	122	112	81	107	103
	..... lbf (kgf)	28,682 (13,010)	26,279 (11,920)	27,403 (12,430)	25,155 (11,410)	18,298 (8,300)	24,119 (10,940)	23,082 (10,470)
Operating weight * (With ROPS/FOPS Cab)		32,959 (14,950)	33,158 (15,040)	32,981 (14,960)	33,246 (15,080)	34,106 (15,470)	33,598 (15,240)	33,665 (15,270)

Note  
 \*: Static tipping load and operating weight marked with\* include 20.5R25 (L3) tires (No ballast) with lubricants, full fuel tank and operator. Machine stability and operating weight depend on counterweight, tire size and other attachments.

### WEIGHT CHANGE

Option item		Operating weight lb (kg)	Tipping load lb (kg)		Overall width in (mm) (outside tire)	Overall height in (mm)	Overall length in (mm)
			Straight	Full turn			
Tire	20.5R25 (L3) VJT	+22 (+10)	+66 (+30)	+66 (+30)	-0.2 (-5)	-0.2 (-5)	±0
Belly guard		+364 (+165)	+265 (+120)	+243 (+110)	±0	±0	±0

### BUCKET SELECTION GUIDE

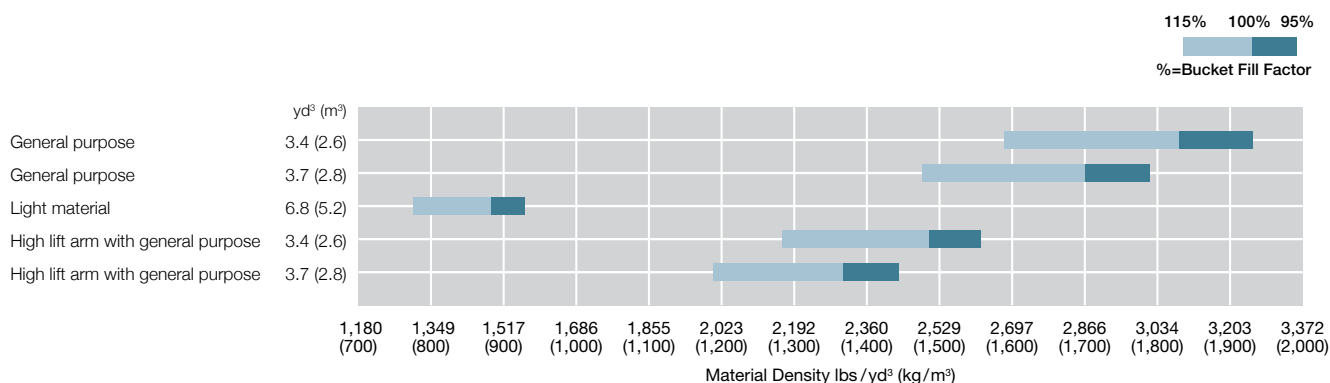

# SPECIFICATIONS

## DIMENSIONS AND SPECIFICATIONS ZW180PL-7

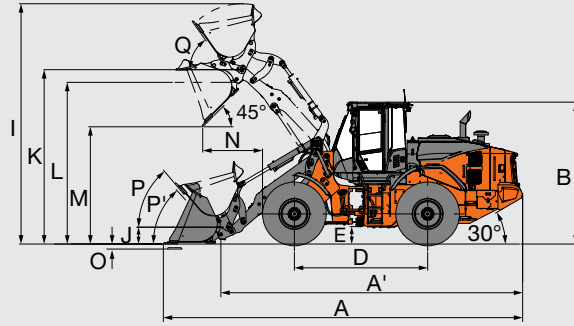
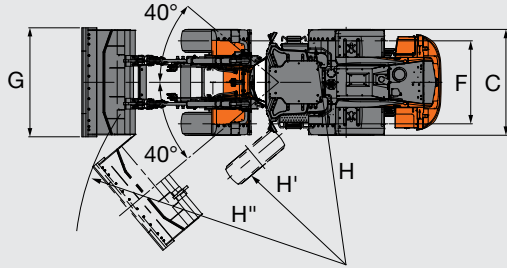

Bucket type			Standard arm						
			Bolt-on cutting edge	Bolt-on cutting edge	Bolt-on cutting edge	Weld-on teeth	Weld-on teeth	Weld-on teeth	
Bucket capacity	ISO 7546: 1983 Heaped	yd <sup>3</sup> (m <sup>3</sup> )	3.4 (2.6)	3.7 (2.8)	4.1 (3.1)	3.3 (2.5)	3.5 (2.7)	3.9 (3.0)	
	ISO 7546: 1983 Struck	yd <sup>3</sup> (m <sup>3</sup> )	3.0 (2.3)	3.1 (2.4)	3.5 (2.7)	2.9 (2.2)	3.0 (2.3)	3.4 (2.6)	
A	Overall length	ft-in (mm)	27' 4" (8,330)	27' 6" (8,380)	27' 10" (8,480)	27' 9" (8,450)	27' 11" (8,500)	28' 3" (8,600)	
A'	Overall length (without bucket)	ft-in (mm)	23' 0" (7,020)	23' 0" (7,020)	23' 0" (7,020)	23' 0" (7,020)	23' 0" (7,020)	23' 0" (7,020)	
B	Overall height up to cab top	ft-in (mm)	10' 10" (3,310)	10' 10" (3,310)	10' 10" (3,310)	10' 10" (3,310)	10' 10" (3,310)	10' 10" (3,310)	
C	Width over tires outside tire	ft-in (mm)	8' 3" (2,505)	8' 3" (2,505)	8' 3" (2,505)	8' 3" (2,505)	8' 3" (2,505)	8' 3" (2,505)	
D	Wheel base	ft-in (mm)	10' 2" (3,100)	10' 2" (3,100)	10' 2" (3,100)	10' 2" (3,100)	10' 2" (3,100)	10' 2" (3,100)	
E	Ground clearance Minimum	ft-in (mm)	1' 4" (400)	1' 4" (400)	1' 4" (400)	1' 4" (400)	1' 4" (400)	1' 4" (400)	
F	Tread	ft-in (mm)	6' 4" (1,930)	6' 4" (1,930)	6' 4" (1,930)	6' 4" (1,930)	6' 4" (1,930)	6' 4" (1,930)	
G	Bucket width	ft-in (mm)	8' 4" (2,535)	8' 4" (2,535)	8' 4" (2,535)	8' 4" (2,535)	8' 4" (2,535)	8' 4" (2,535)	
H	Turning radius (centerline of outside tire)	ft-in (mm)	17' 2" (5,235)	17' 2" (5,235)	17' 2" (5,235)	17' 2" (5,235)	17' 2" (5,235)	17' 2" (5,235)	
H'	Turning radius to inside of tires	ft-in (mm)	9' 10" (2,995)	9' 10" (2,995)	9' 10" (2,995)	9' 10" (2,995)	9' 10" (2,995)	9' 10" (2,995)	
H''	Loader clearance radius, bucket in carry position	ft-in (mm)	20' 4" (6,190)	20' 4" (6,205)	20' 5" (6,230)	20' 5" (6,225)	20' 6" (6,240)	20' 7" (6,270)	
I	Overall operating height bucket full raise	ft-in (mm)	18' 4" (5,590)	18' 6" (5,650)	18' 9" (5,720)	18' 4" (5,590)	18' 6" (5,650)	18' 9" (5,720)	
J	Carry height of bucket pin at carry position	ft-in (mm)	1' 4" (400)	1' 4" (400)	1' 4" (400)	1' 4" (400)	1' 4" (400)	1' 4" (400)	
K	Height to bucket hinge pin, fully raised	ft-in (mm)	13' 3" (4,050)	13' 3" (4,050)	13' 3" (4,050)	13' 3" (4,050)	13' 3" (4,050)	13' 3" (4,050)	
L	Lift arm clearance at max lift	ft-in (mm)	12' 4" (3,760)	12' 4" (3,760)	12' 4" (3,760)	12' 4" (3,760)	12' 4" (3,760)	12' 4" (3,760)	
M	Dumping clearance 45 degree, full height	ft-in (mm)	8' 11" (2,720)	8' 10" (2,690)	8' 7" (2,620)	8' 8" (2,650)	8' 7" (2,610)	8' 4" (2,540)	
N	Reach, 45 degree dump, full height	ft-in (mm)	4' 7" (1,390)	4' 8" (1,420)	4' 11" (1,490)	4' 11" (1,510)	5' 1" (1,540)	5' 3" (1,610)	
O	Digging depth (horizontal digging angle)	ft-in (mm)	0' 4" (110)	0' 4" (110)	0' 4" (110)	0' 3" (80)	0' 3" (80)	0' 3" (80)	
P	Max. roll back at carry position	deg	50	50	50	50	50	50	
P'	Max. roll back at ground level	deg	48	48	48	48	48	48	
Q	Roll back angle at full height	deg	55	55	55	55	55	55	
Bucket weight			lb (kg)	2 844 (1,290)	2 932 (1,330)	3 064 (1,390)	2 624 (1,190)	2 712 (1,230)	2 844 (1,290)
Static tipping load ISO 14397-1: 2007 (Section 1-5) *	Straight	lb (kg)	23,744 (10,770)	23,656 (10,730)	23,523 (10,670)	24,097 (10,930)	23,898 (10,840)	23,766 (10,780)	
	Full turn	lb (kg)	20,415 (9,260)	20,349 (9,230)	4,365 (1,980)	20,723 (9,400)	20,547 (9,320)	20,437 (9,270)	
Breakout force		kN	112	108	101	120	116	108	
		lbf (kgf)	25,133 (11,400)	24,251 (11,000)	22,708 (10,300)	26,896 (12,200)	26,015 (11,800)	24,251 (11,000)	

Bucket type	Standard arm					
	Bolt-on cutting edge	Bolt-on cutting edge	Bolt-on cutting edge	Weld-on teeth	Weld-on teeth	Weld-on teeth
Operating weight * (With ROPS/FOPS Cab).....lb (kg)	34,414 (15,610)	34,502 (15,650)	34,635 (15,710)	34,194 (15,510)	34,282 (15,550)	34,414 (15,610)

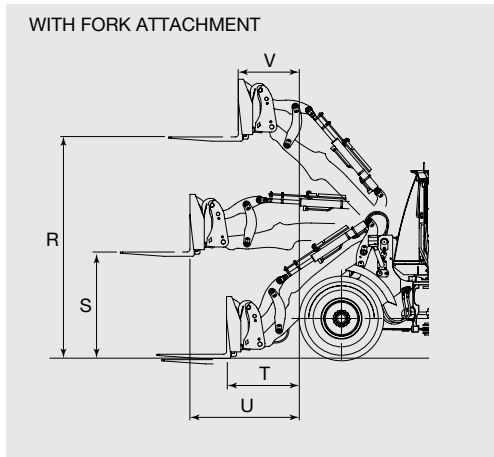

Attachment type		Fork
R	Max. stacking height .....	12' 7" (3,830)
S	Height of fork at maximum reach ...	5' 11" (1,810)
T	Reach at ground level .....	4' 4" (1,310)
U	Max. reach .....	6' 3" (1,910)
V	Reach at max. stacking height .....	3' 6" (1,070)
Static tipping load	Straight .....	18,783 (8,520)
	Full 40 degree turn .....	16,292 (7,390)
Max. payload per EN 474-3, 80 % .....		15,344 (6,960)
Max. payload per EN 474-3, 60 % .....		11,508 (5,220)
Fork tine length .....		4' 0" (1,220)
Operating weight * .....		33 025 (14,980)

Note: \*: Static tipping load and operating weight marked with\* include 20.5R25 (L3) tires (No ballast) with lubricants, full fuel tank and operator. Machine stability and operating weight depend on counterweight, tire size and other attachments.

### WEIGHT CHANGE

Option item		Operating weight lb (kg)	Tipping load lb (kg)		Overall width in (mm) (outside tire)	Overall height in (mm)	Overall length in (mm)
			Straight	Full turn			
Tire	20.5R25 (L3) VJT	+22 (+10)	+44 (+20)	+44 (+20)	-0.2 (-5)	-0.2 (-5)	±0
Belly guard		+364 (+165)	+265 (+120)	+243 (+110)	±0	±0	±0

### BUCKET SELECTION GUIDE

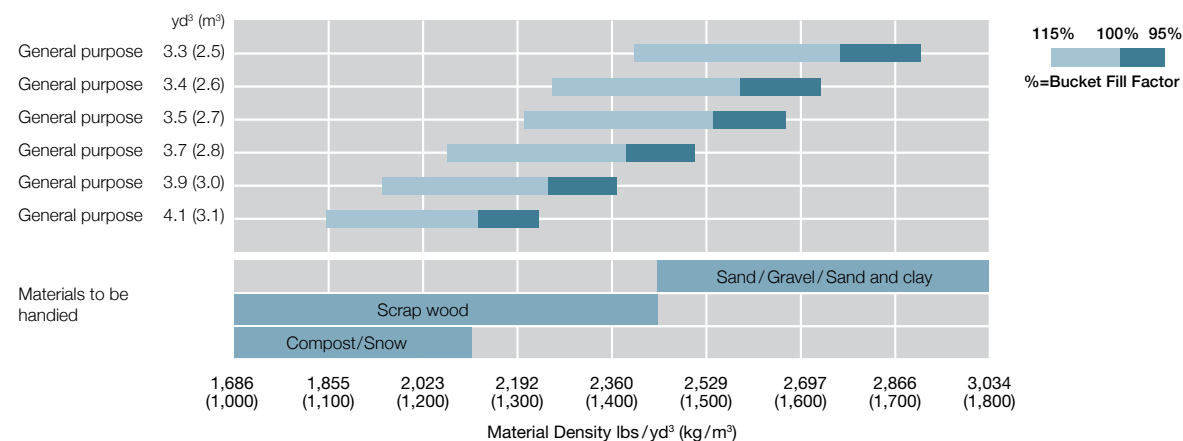

# EQUIPMENT

●: Standard equipment ○: Optional equipment

ENGINE	ZW180-7	ZW180PL-7
Aftertreatment device	●	●
Aftertreatment manual regeneration inhibit switch	●	●
Aftertreatment manual regeneration switch	●	●
Air filter double elements	●	●
Air intake		
Pre-cleaner (sy-clone type)	●	●
Pre-cleaner (Turbo II)	○	○
Anti-clogging radiator (wide fin pitch)	●	●
Automatic reversible cooling fan with heat sensing	●	●
Cartridge-type engine oil filter	●	●
Cartridge-type fuel main filter	●	●
Cartridge-type fuel pre-filter (with water separator function)	●	●
Coolant reservoir sight gauge	●	●
DEF/AdBlue® tank	●	●
DEF/AdBlue® tank with magnet adapter	●	●
Engine auto shut-down control system	●	●
Engine oil remote drain	●	●
Fan guard	●	●

BRAKE SYSTEM	ZW180-7	ZW180PL-7
Front and rear independent brake circuit	●	●
Inboard mounted fully hydraulic 4 wheel wet disc	●	●
Spring-applied/Hydraulic-released parking brake	●	●

HYDRAULIC SYSTEM	ZW180-7	ZW180PL-7
Bucket auto leveler (automatic return to dig control)	●	●
Control lever lock switch	●	●
Dual lift arm auto leveler and kickout system	●	●
Electric control lever		
for 3 spools control valve		
MF lever and Proportional switch for 3rd function	●	●
2 levers and AUX lever for 3rd function – Inside layout pattern (3rd – bucket – liftarm)	○	○
Hydraulic filters	●	●
Lift arm float system	●	●
Quick coupler piping and switch	●	●
Reservoir sight gauge	●	●
Ride control system (OFF-AUTO type)	●	●
Work mode selector	●	●

CAB	ZW180-7	ZW180PL-7
Adjustable steering column with POP-UP	●	●
Auto control air conditioner		
Pre-cleaner for air conditioner	○	○
with double intake filter	●	●
Bluetooth® integrated DAB+radio, hands-free calling	●	●
Camera and monitor		
AERIAL ANGLE (Side and rear view camera)	○	○
Rear view camera and monitor	●	●
Coat hook	●	●
Evacuation hammer	●	●
Front/rear defroster	●	●
Glove compartment	●	●
LED room light	●	●
Payload checker with tip-off function	●	-
Rear obstacle detection system	○	○
Rear view mirrors		
Inside (1)	●	●
Standard outside mirrors	●	●
Premium Outside (heated, 2) electrical adjustment with proximity	○	○
Retractable seat belt, 3.0 in (76 mm)	●	●
ROPS (ISO 3471: 2008), FOPS (ISO 3449: 2008 LEVEL II): multi-plane isolation mounted for noise, vibration reduction	●	●
Rubber floor mat	●	●
Seat		
Heavy duty air suspension seat equipped with horizontal suspension headrest and heater: fabric, high back, adjustable for damper, inclination of the seat, seat depth, weight-height, fore-aft position, reclining angle, armrest angle, headrest height and angle, lumbar support	●	●
Seat belt reminder	●	●
Steering system		
Wheel steering	●	●
Storage		
Cup holder	●	●
Document holder	●	●
Hot and cool box	●	●
Seatback pocket	●	●
Smartphone and Tablet device holder	●	●
Sunscreen roller type	●	●
Textured steering wheel with spinner knob	●	●
Tinted safety glass		
Front windshield: laminated	●	●
Others: tempered	●	●
USB power supply	●	●
Windshield washer front and rear	●	●
Windshield wipers front and rear	●	●
2 speakers	●	●
8 inch sub monitor	●	●



●: Standard equipment ○: Optional equipment

MONITORING SYSTEM	ZW180-7	ZW180PL-7
Gauge: coolant temperature, fuel level, transmission oil temperature	●	●
Indicator lights: clearance lights, control lever lock, fuel level, high beam, parking brake, preheat, turn signals, work lights, fan reverse indicator, seat belt indicator	●	●
Indicator on multifunction monitor: F-N-R shift position, gear shift position, clock, DEF alarm indicator, DEF level gauge, ECO indicator, forward/reverse selector switch indicator, hold display, hour meter, odometer, battery volt, speedometer, tachometer, transmission auto-shifting indicator, Warning lights: air filter restriction, brake oil low pressure, communication system error, discharge warning, engine oil low pressure, engine warning, hydraulic oil level, low steering oil pressure, overheat, transmission warning	●	●
Indicator on sub monitor: payload checker (excluding PL), dual auto-leveler indicator rear obstacle detection and warning system (optional)	●	●
38 languages selection	●	●

ELECTRICAL SYSTEM	ZW180-7	ZW180PL-7
Alternator (95 A)	●	●
Backup alarm	●	●
Battery disconnect switch	●	●
Large capacity batteries	●	●
Power outlet 12 V and 24 V	●	●

LIGHTS	ZW180-7	ZW180PL-7
Clearance lights	●	●
LED brake and tail lights	●	●
LED headlights	●	●
Rotating lamp	○	○
Turn signals with hazard switch	●	●
Work lights		
premium work light package 4 front, 2 rear on cab and 2 rear LED working lights	●	●

POWER TRAIN	ZW180-7	ZW180PL-7
Approach speed control	●	●
Automatic transmission with load sensing system	●	●
Clutch cut position switch	●	●
Differential		
LSD (limited slip differential, front and rear)	●	●
Driving speed limiter 12.4 mph (20 km/h)	○	○
DSS (down shift switch)	●	●
Forward/reverse lever	●	●
Maximum gear limited switch	●	●
Power mode switch	●	●
Quick power switch	●	●
Travel mode selector (auto1-auto2)	●	●

TIRES	ZW180-7	ZW180PL-7
20.5R25 (L3) VJT	●	●

MISCELLANEOUS	ZW180-7	ZW180PL-7
Articulation lock bar	●	●
Auto lubrication system	○	○
Belly guard (bolt on type) (front/rear)	○	○
Bucket cylinder guard	○	○
Cab top rail		
Front rail on the cab top	●	●
Rear rail on the cab top	●	●
Counterweight, built-in	●	●
Drawbar with locking pin	●	●
Emergency steering	○	○
Fenders		
for 20.5 R25 (front and half rear fenders with mud flaps)	●	●
for 20.5 R25 (front and full covered rear fenders with mud flaps)	○	○
Global e-Service	●	●
Lift and tie down hooks	●	●
Lift arm		
High lift arm	○	-
Parallel lift arm	-	●
Standard lift arm	●	-
On board information controller	●	●
Vandal Protection		
Battery cover with locking bracket	●	●
Lockable engine cover	●	●
Lockable fuel refilling cap	●	●
Quick coupler	○	○
Radiator dust protection screen	○	○
Standard tool kit	●	●
Tool box	●	●



# HITACHI

Reliable solutions



REPUTATIONS ARE  
**BUILT ON IT.**

With manufacturing facilities in Banshu, Ryugasaki, Tierra, Hitachinaka, and Tsuchiura, Japan, and the U.S. corporate office and campus in Newnan, Georgia, Hitachi Construction Machinery Americas Inc. (HCMA) has the experience and technology to design, engineer, manufacture, and service your Hitachi construction machinery. The HCMA team is securely poised as your go-to source in the North American and Latin American construction machinery markets.

Through our long-term commitment to maintaining a leadership position in technology, service, and support, HCMA supports an extensive network of independent, local dealers focused on providing you with knowledgeable and experienced sales, service, and parts personnel — all backed by dedicated HCMA support teams.

Your Hitachi Construction Machinery Americas dealer has the resources, expertise, and personnel to work with you to ensure that you receive the most benefit from your investment, utilizing carefully designed programs and services in conjunction with extensive digital resources. HCMA provides a totally focused approach to supporting you, your business, and your construction machinery.

Machines representative of global product. Options may not be available in all markets. Prior to operating this machine, including satellite communication system, in a country other than a country of its intended use, it may be necessary to make modifications to it so that it complies with the local regulatory standards (including safety standards) and legal requirements of that particular country. Please do not export or operate this machine outside the country of its intended use until such compliance has been confirmed. Please contact your Hitachi Construction Machinery Americas dealer in case of questions about compliance.