



Material Transfer Vehicle

SB-1500

ENGINE

SB-1500e: Tier 4F, Cummins® QSL9 300 hp (224 kW) @ 2,000 rpm

SB-1500ex: Teir 3, Cummins® QSL9 300 hp (224 kW) @ 2,000 rpm

OPERATING WEIGHT

67,240 lbs (30,500 kg)





Roadtec — An Astec Industries Company

Roadtec, Inc. is proud to be a part of the family of companies that make up Astec Industries, Inc. Founded in 1972, Astec Industries, has grown to become America's leading manufacturer of equipment for asphalt road building, aggregate processing, oil, gas and water well drilling and wood processing. Roadtec continues to be an industry leader together with Astec Industries, by applying Astec's model of creative thinking bolstered by a corporate culture renowned for putting customer service first.



THE ROADTEC DIFFERENCE: DELIVERING QUALITY AND INNOVATION WITH SUPERIOR CUSTOMER SERVICE

Dependability

Roadtec has been manufacturing innovative, heavy-highway equipment since 1981. We continue to grow and add new products, yet our personal connection to our customers and our ability to respond immediately to your needs is even stronger.

Customer Service

Our customers benefit from our strong focus on customer support after the sale. In-the-field service technicians live in the regions where they work and respond quickly. 24/7 parts support will get you the right parts fast, and at a fair price. Our product specialists will train your people on any newly purchased machine, and we also offer industry-leading training at our state-of-the-art training facility or in the field.

Count on Roadtec Equipment

We don't build roads. We make the equipment so you can cost-effectively build and maintain the world's roads. With the Roadtec heavy-duty design, we are able to keep your machine working longer while lowering maintenance and operating costs. We are also able to make your operators more comfortable and confident with our user-friendly design and our customization for special projects.



THE ROADTEC SHUTTLE BUGGY® MTV GIVES YOU SUPERIOR MAT QUALITY AND EFFICIENCY ON THE JOBSITE

Material Transfer Vehicles (MTVs) : A Must-Have

In 1935 Harry Barber launched his invention, the very first asphalt paver. As you might imagine road building was forever changed for the better. However, road paving technology would not significantly change again until 1989 when Roadtec introduced the very first material transfer vehicle, the Roadtec Shuttle Buggy® MTV. Roadtec material transfer technology led the way to dramatically improved pavement life and quality, making Roadtec MTV's an essential tool for today's road builders.

SB-1500: At a Glance

The Roadtec Shuttle Buggy® material transfer vehicle SB-1500 features a low weight and narrower wheel base. It can store up to 15 tons (13.6 mt) of asphalt mix, allowing haul vehicles to unload as soon as they arrive. This substantially reduces trucking costs. The SB-1500 features an end dump hopper or an optional windrow pickup head. It also features the patented anti-segregation auger which remixes materials for control of aggregate and temperature segregation.

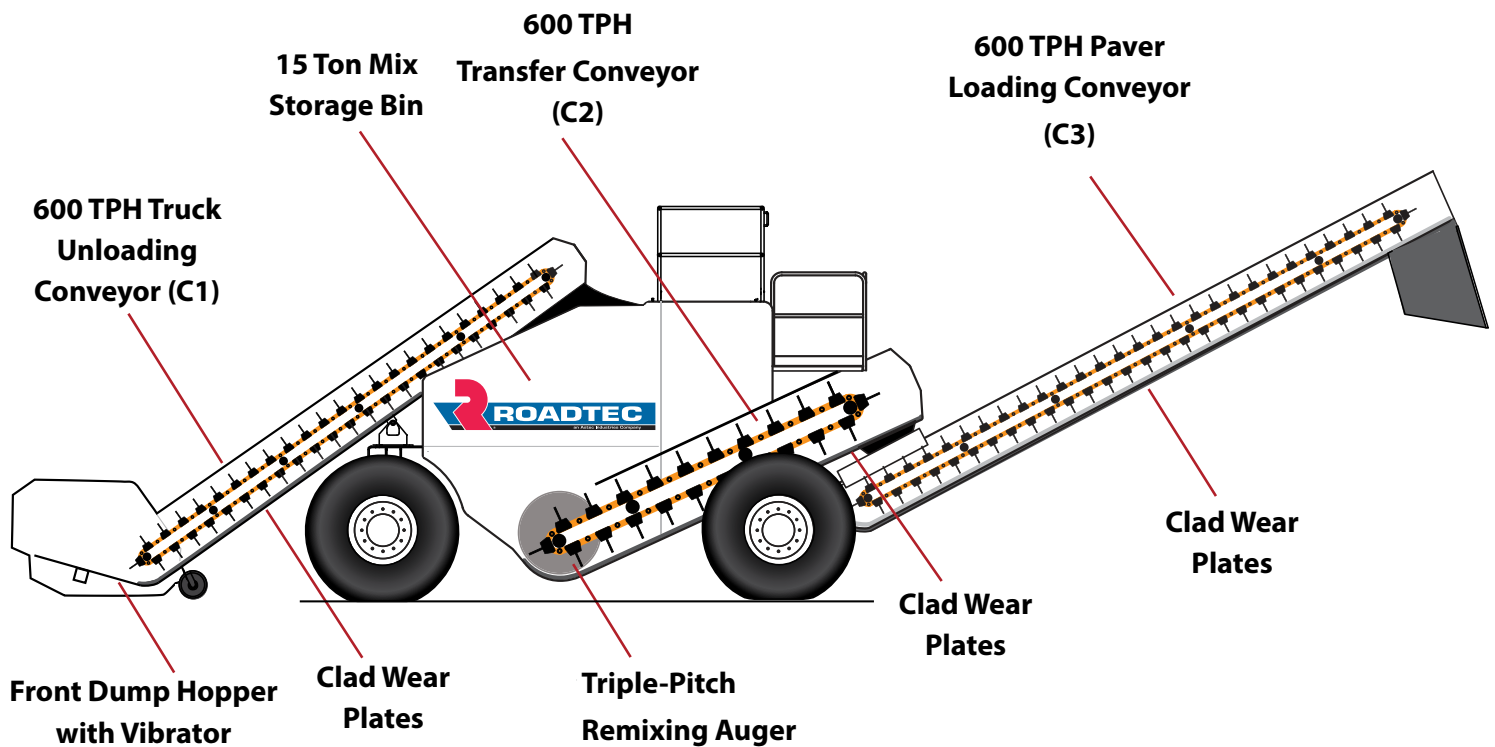

Roadtec MTV Experience

MTV's lead a tough life. They're subject to getting bumped by trucks, they get 16 plus tons of hot mix dumped into them in less than a minute, they keep the abrasive material moving and mixing, and they feed the paver at rates up to 600 tons per hour. Materials and workmanship must stand up to those demands. With Roadtec, you'll get a heavy-duty design you can rely on, coupled with the functionality you need.

Road Builders Rely on MTVs

The Shuttle Buggy® MTV is the only machine that combines the benefits of a remixing material transfer with unmatched reliability. That's why road builders worldwide recognize the value of using Roadtec's Shuttle Buggy® MTV to construct high quality asphalt pavements.

Important Benefits

Truck handling, temperature and material segregation all contribute to poor pavement quality. The Roadtec Shuttle Buggy® MTV provides a solution for all of these issues by remixing material onsite while allowing the paver to operate at a constant speed without stopping.

- Temperature Segregation during transport cannot be avoided. Without remixing, the colder material will screed out together and form a potential trouble spot.
- The Shuttle Buggy® MTV allows continuous paving, which leads to a much smoother surface.
- The machine has a storage capacity of 15 tons (13.6 mt), allowing the contractor to use fewer trucks by unloading them quickly so they can return to the plant.

DRIVE PROFITS BY ELIMINATING TRUCK DELAYS AND KEEPING YOUR PAVER MOVING WITH ON-SITE MIX STORAGE



Frame

The SB-1500 has an extremely strong frame that is fabricated, welded and assembled by Roadtec.

Parts Made for Durability

All conveyors are outfitted with durable roller bushing chain. Flights are made of abrasion-resistant steel, and we install thick wear plate linings on the conveyor floors. The floor of the paver loading conveyor is insulated against heat loss. Rails installed at the bottom of this conveyor help protect it from any damage that could be caused by impact with the paver.



Front Hopper Performance Features

Sized for mass discharge from standard haul trucks, the front hopper allows trucks to unload fast. A vibrating bottom plate in the hopper prevents material build-up. Heavy-duty, swiveling support casters under the hopper assure smooth movement. Ground operators can adjust the hopper and baffle position from either side.

Better Maintenance Access

Engine access is gained by hydraulically lifting the one-piece hood. There are hinged access doors that make the oil cooler, radiator and pumps easy to reach. Hydraulically operated clean-out doors are found at each conveyor.

Options

- Road Light Package – Six 24V road lights
- Night Light Package – Includes five 24V HID lights mounted at the corners of the machine & C3
- Automated lubrication system
- Automated release agent spray-down system
- Windrow pick up head instead of dump hopper
- (2) color, night-vision-capable cameras, one on the front and one on the back of the machine. Includes color monitor in waterproof case.
- 4kW or 6.2 kW continuous duty hydraulic generator
- Truck dump signal light
- Dump hopper landing lights
- Bindicator Package



SIMPLIFY DIFFICULT PAVING JOBS AND INCREASE PRODUCTIVITY

Intersection Pay-off

Intersection work is typically slow, and getting trucks to the paver is often difficult. The Shuttle Buggy® is able to improve the maneuverability of your pavers on intersection work by freeing them from trucks.

Standard Pivoting Discharge Conveyors

The discharge conveyor swings 45° right or left, allowing you to do offset paving and to save significant time and dollars when adding lanes, or working with string lines or barriers. This feature also lets you keep trucks off the milled edge and off the tack coat. Specialty projects, such as high-banked racetracks or airports requiring string lines on both sides, are paved much easier with Roadtec's standard pivoting conveyors.

Make Tricky Paving Projects Easy

Parking areas that have a lot of islands or peninsulas are difficult to pave. Overhead power lines, tunnels, overpasses and other obstructions can present a different challenge. It's often impossible to form a good paving train and get the material in front of the paver. When you have a Shuttle Buggy® MTV the truck can unload at a convenient spot and the Shuttle Buggy® can bring the mix to the paver.

Speed Up Handwork

At times, there are spots that a paver can't reach, no matter what, and handwork is required. Roadtec MTV's are able to carefully dispense material to the workers exactly where they need it because the discharge conveyor can be lowered and pivoted from side to side.

ACHIEVE UNIFORM REMIXING AND MEET YOUR TOUGHEST JOB SPECIFICATIONS WITH ROADTEC REMIXING TECHNOLOGY

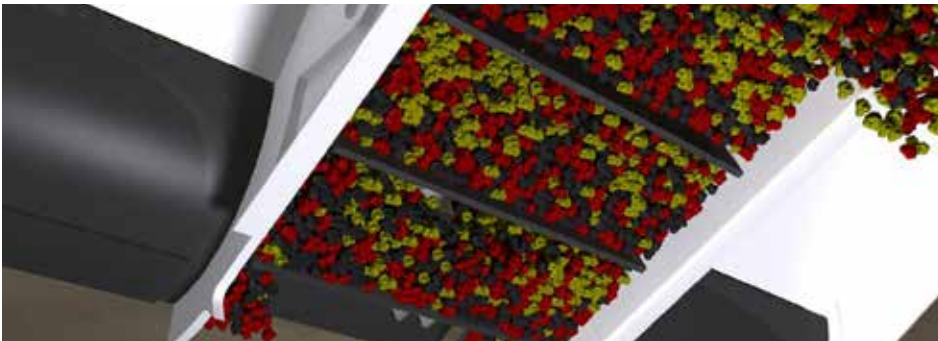
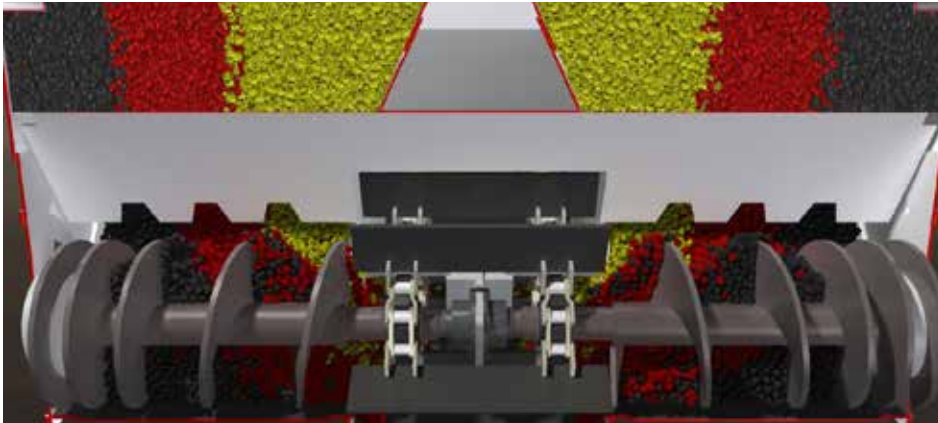

Shuttle Buggy® MTV Triple Pitch Auger Design

The triple-pitch auger flighting design used in Roadtec Shuttle Buggy® MTV's provides uniform remixing across the width of the entire hopper. The triple-pitch auger located in the bottom of the hopper remixes the contents of the storage hopper. The mixing action equalizes temperatures and evenly mixes large and small particles. A slat conveyor runs from the bottom of the hopper and feeds the discharge conveyor.

Why Segregation is a Problem

Segregation in asphalt pavements will compromise their surface and structure. Cracking, raveling, stripping, and rutting are all pavement failures linked to segregation. Temperature and material segregation have also been known to hinder the compaction of the asphalt mat, and non-uniform density will result in pavement failure.

Control Over Segregation

It is extremely difficult to eliminate all the potential causes of segregation in asphalt mixes. However, the presence of thermal and/or material segregation can be corrected before the new surface is paved. With Roadtec's material transfer technology, you can depend on thoroughly remixed material that is evenly distributed as it's paved.

Single-Pitch Augers Don't Remix

Single-pitch flighting pulls material primarily from the sides of the bin. The spaces between flights fill up and the auger just tunnels through. The contents of the bin are not remixed, and therefore segregation remains a problem. The Roadtec Shuttle Buggy® material transfer vehicles use a triple-pitch auger design. This Roadtec innovation is key for achieving the best mixing results, and will help you meet the tightest temperature segregation specifications.

Proof in Thermal Imaging: Achieve superior results

Infrared images show the quality of remixing that takes place with different devices. Time after time Roadtec machines have consistently performed better than others. Roadtec mixing technology is better engineered and achieves superior results. Infrared images have been taken behind numerous machines and are shown below. Color variations in the infrared photos show temperature variations. Uniform density cannot be achieved when mix temperatures vary. Cold spots become potholes.

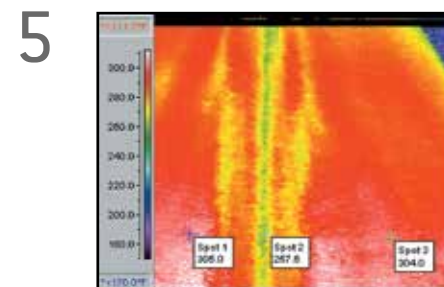
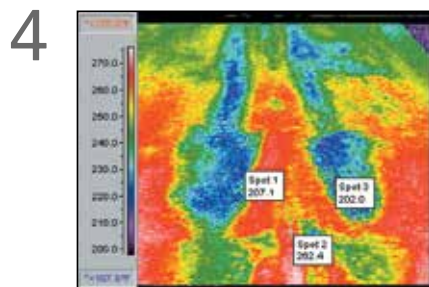
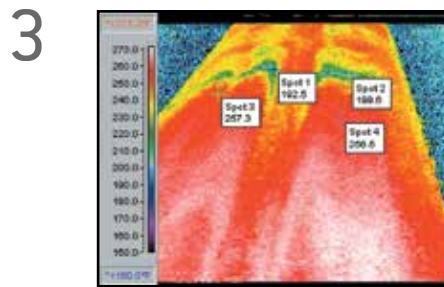
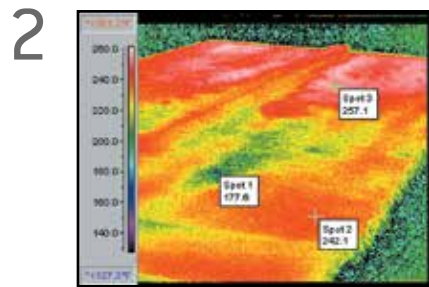
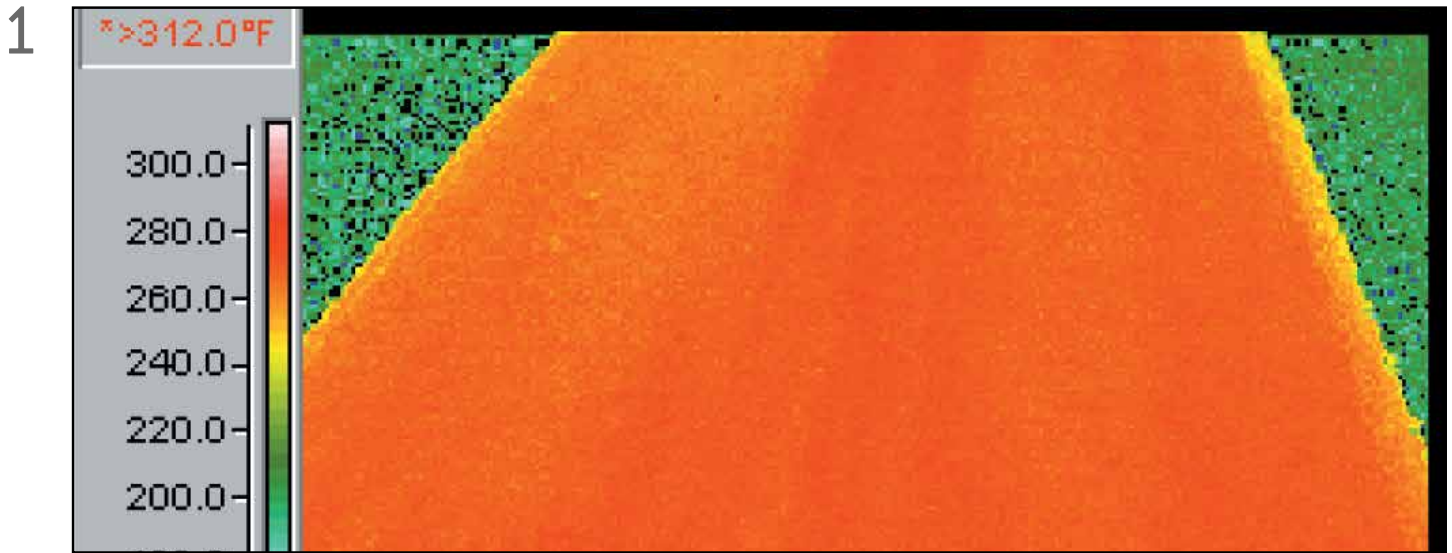

1. Roadtec Shuttle Buggy
MTV - Virtually no
temperature difference.
2. Windrow Pickup Machine
3. Windrow Pickup Machine
with
Truck Dumping Head
4. Belt Conveyor Type
Material Transfer Vehicle
5. Belt Conveyor Type
Material Transfer
Vehicle with add-on
pugmill

SPECIFICATIONS

ENGINE

- SB-1500e: Tier 4F, Cummins® QSL9 300 hp (224 kW) @ 2,000 rpm
- SB-1500ex: Teir 3, Cummins® QSL9 300 hp (224 kW) @ 2,000 rpm

WEIGHT

- 67,240 lbs (30,500 kg)

CONSTRUCTION

- Heavy-duty conveyor flights and chain. Replaceable wear plate in all high wear areas. Stability without unnecessary weight.

COOLING SYSTEM

- Dual, quiet operation fans

ELECTRICAL SYSTEM

- Two 4D batteries & 115 amp alternator
- 24V system with master disconnect switches.
- Electric-over-hydraulic solenoids with manual override.

PROPEL SYSTEM

- Hydrostatic drive
- Continuously variable speed control -two speed ranges

SPEED

- Working: 0-2.8 mph (0-4.5 kph)
- Travel: 0-11.4 mph (0-18.4 kph)

BRAKE SYSTEM

- Hydrodynamic disc caliper brakes, and parking brake

TIRES

- Large, high-flotation - 18" x 25" (457 mm x 635 mm)

OPERATOR STATIONS

- Two operator stations with deluxe adjustable seats
- Center control console pivots to right or left

GROUND CONTROLS

- (2) front dump hopper control boxes

FUME EXTRACTION SYSTEM

- Two blowers. Fold-down 10" (254 mm) exhaust pipes

TRUCK DUMP HOPPER

- Front hopper has swivel support casters. Vibrating floor plate. 9'2" (2,794 mm) wide truck opening
- Hydraulic, adjustable push rollers.
- Hydraulic hopper baffle adjustable for optimal material flow.

DUMP HOPPER TRANSVERSE AUGER

- 22" (559 mm) o.d. cast, segmented auger.

DUMP HOPPER UNLOADING CONVEYOR (C1)

- Drag conveyor with 600 tph (544 mtph) capacity.
- Dual roller bushing chain.
- Weld-on flights 5/8" (16 mm) thick, 5 9/16" (142 mm) wide x 33 3/4" (857 mm) long. Ni-Hard liner plates.

SURGE BIN

- 15 tons (13.6 mt) storage capacity.

REMIXING AUGER IN SURGE BIN

- 22" (559 mm) o.d. cast, segmented augers

SURGE BIN UNLOADING CONVEYOR (C2)

- Drag conveyor with 600 tph (544 mtph) capacity.
- Dual roller bushing chain.
- Weld-on flights 5/8" (16 mm) thick, 7" (178 mm) wide x 35 1/2 (902 mm) long. Ni-Hard liner plates are replaceable.

PAVER LOADING CONVEYOR (C3)

- Drag conveyor with 600 tph (544 mtph) capacity.
- Dual roller bushing chain.
- Conveyor flights welded to the chain are 1/2" (12.7 mm) thick, 4 3/4" (121 mm) wide and 30" (762 mm) long Conveyor has bolted 1/2" (12.7 mm) AR500 replaceable floor plates and doors.
- Controls interlock with surge bin unloading conveyor.

SERVICE CAPACITIES

- Fuel tank.....110 gal (416 l)
- Hopper.....15 tons (13.6 mt)
- Material.....110 lbs/cu ft (1,762 kg/cu m)

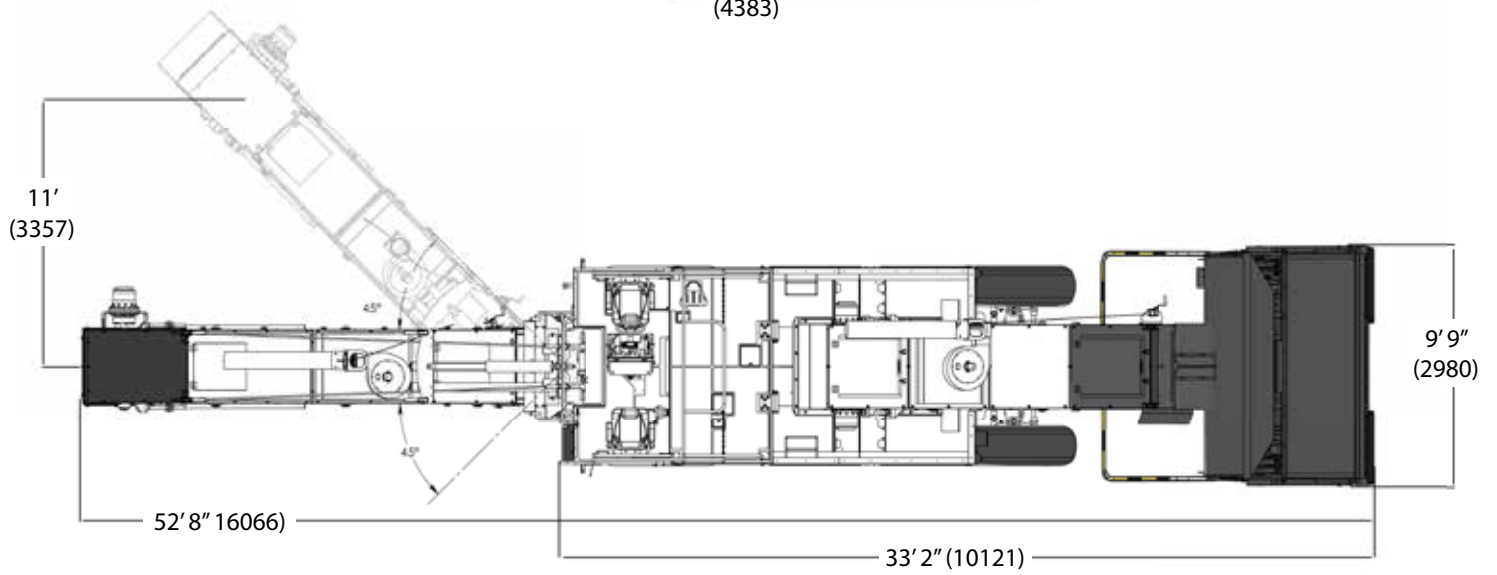
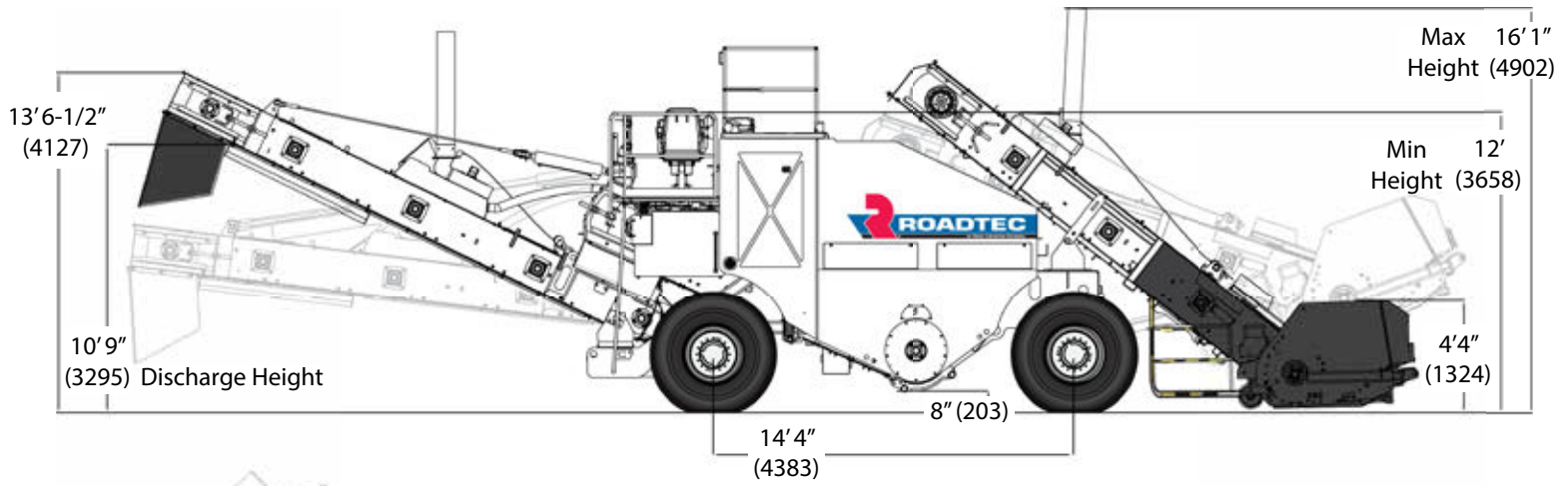

Dimensions in brackets are mm.

Specifications are subject to change without notice.

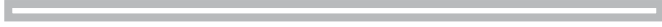
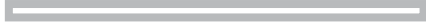

ROADTEC.COM

ROADTEC an Astec Industries Company

800 MANUFACTURERS RD • CHATTANOOGA, TN 37405 USA • 800.272.7100 • FAX 423.267.7104 • roadtec.com

2/20/2015



© 2014 Roadtec, Inc. All Rights Reserved