

Product Information Material Handling Machine

LH 26 Industry

Litronic®

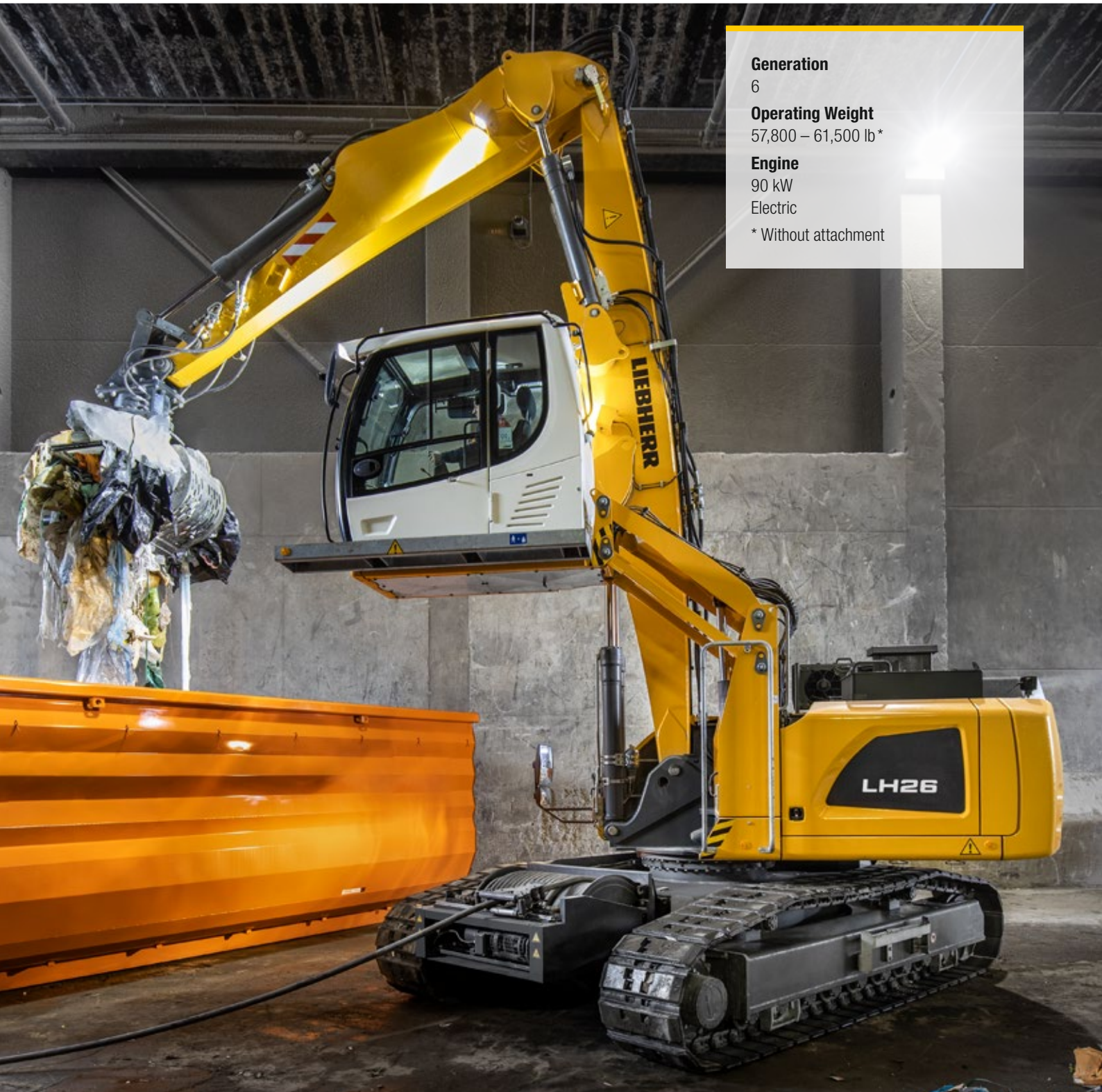

Generation

6

Operating Weight

57,800 – 61,500 lb*

Engine

90 kW

Electric

* Without attachment

LIEBHERR

Performance

Power Plus Speed –
Redefined Performance

Economy

Good Investment –
Savings for Long-term

LH 26 M Industry Litronic

Operating Weight
57,800 – 58,400 lb*

Engine
90 kW
Electric

LH 26 C Industry Litronic

Operating Weight
58,900 – 61,500 lb*

Engine
90 kW
Electric

* Without attachment



Reliability

Durability and Sustainability –
Quality Down to the Last Detail

Comfort

Perfection at a Glance –
When Technology is Comfortable

Maintainability

Efficiency Bonus –
Even with Maintenance and Service



Well Thought Out to the Last Detail





Frequency Converters

- Individual adjustment of the speed
- Gentle start to avoid activation current peaks during starting
- Simple adjustment to all conventional power supply networks
- Separate extendable safety guard



Extremely Dusty Jobs

- Largescale cooler with large mesh for excellent cooling capacity
- Recycling package with reversible fan and separate position of the air conditioning condenser to delay the engine and cooler becoming contaminated and thus ensuring high machine availability



Innovative Drive Concept

- Liebherr electric motor for powerful and dynamic movements
- Additional electric motor for auxiliary consumers results in deliberate energy distribution and maximum energy efficiency

Convincing in Operation



Performance

Advanced Technology

The frequency converter guarantees the flexibility required by the electric motor to suit the job in hand. As a result of its function as a speed regulator, it enables sensitive, dynamic work movements to be performed and combines precision with speed. This is the basis for the LH 26 Electric machine delivering the same performance as the equivalent diesel engine.

Rapid Work Cycles

The LH 26 electrical handling machine features the load-sensing control system. This divides the fluid delivered by the pump independently of the load pressures. This, in turn, means that the parallel actuation of multiple consumers, such as moving the equipment or the uppercarriage, does not affect their speed. The benefit is that this makes superimposed movements possible to achieve a significantly higher handling capacity.

Economy

Sensor Controlled Low Idle Automatic

The time-tested standard sensor controlled low idle automatic reduces the engine speed to idling level as soon as the operator takes his hand off the joystick which means that no hydraulic functions are activated. In addition to saving energy, this also reduces noise.

Optimized Running Costs

The low maintenance requirement reduces service costs and guarantees high machine availability. The frequency converter technology used on the LH 26 Electric significantly reduces electricity costs compared to systems without frequency converters. The reason for this is that the reserve power required for commissioning the machine and the reactive currents whilst the machine is operating are lower.

Reliability

Quality and Competence

Our experience, understanding of customer needs and the technical implementation of these findings guarantee the success of the product. For decades, Liebherr has been inspirational with its depth of production and system solutions. Key components such as the diesel engine and electric motors, electronic components, slewing ring, slewing drives and hydraulic cylinders are developed and produced by Liebherr itself. The great depth of in-house manufacturing guarantees maximum quality and ensures that components are optimally configured to each other.

Protecting the Components

As a power converter, the frequency converter provides a direct power supply and control for the electric motor by adjusting to the local power supply network and ensures that the motor can be started gently to protect the hydraulic drive components, ensuring that they deliver a long service life.

Working Area Limit

The handling machine can be fitted with an optional working area limit for jobs which require a limited working area. Every possible dimensional can be adjusted for this purpose – height, depth, reach and proximity. This can prevent collisions and the resulting component damage.

Comfort

Auxiliary Air Conditioning System

The standard auxiliary air conditioning system delivers a perfect climate for the cab regardless of the actual ambient conditions. This function is delivered independently of the main motor and is available to the operator at all times.

Ergonomic

The latest cab design delivers excellent conditions for healthy, highly concentrated and productive work in maximum comfort. Both the display unit with touchscreen colour display, the controls and Comfort driver's seat are all coordinated to form a perfect ergonomic unit. In addition the ergonomic joysticks allow the machine operation to be both pleasant and precise.

Proportional Control System

Precision and the fine control of the handling machine are particularly important for applications such as material sorting or scrap recycling. The machine can master this demanding work with ease thanks to its standard proportional control system.

Maintainability

Low Maintenance Electric Motor

The LH 26 Electric combines time-tested technology with a new electric drive concept – low maintenance, low noise and unaffected by statutory emissions standards. The heart of the machine is the 90 kW electric motor which powers the hydraulic pump directly and with infinite variation.

Service-based Machine Design

The service-based machine design guarantees short maintenance times, thus minimising maintenance costs due to the time it saves. All the maintenance points are easily accessible from the ground and easy to reach due to the large, wide-opening service doors. The enhanced service concept places the maintenance points close to each other and reduces their number to a minimum. This means that service work can be completed every more quickly and efficiently.

Integral Maintenance Benefits

The completion of maintenance work helps keep the machine fully functional. Maintenance work does, however, mean machine down times which must be minimised. Automatic central lubrication systems for the uppercarriage and equipment as well as optional systems for the undercarriage, rapid change systems and attachments not only make it easier to adhere to the prescribed lubrication intervals and ensure a long service life for the components, but also increase the productivity of the Liebherr LH 26 Electric Industry handling machine.

Technical Data



Electric Motor

| | |
|---|--|
| Rating | 90 kW at 1,800 rpm |
| Model | Liebherr KGF898/4 |
| Type | three-phase squirrel cage motor |
| Secondary electric motor | |
| Electric motor auxiliary equipment (air-conditioning compressor, alternator 24 V) | 15 kW |
| Electrical system energy supply | Liebherr drive components and control cabinets for uppercarriage and undercarriage Liebherr frequency converter fed drive system heavy-duty version |
| Manufacturer | Liebherr |
| Supply voltage | |
| Low voltage | 380 V, 400 V |
| Frequency | 50/60 Hz |
| Engine idling | sensor controlled |
| Electrical system | battery-assisted control system, lighting, diagnostics system |
| Voltage | 24 V |
| Batteries | 2 x 135 Ah/ 12 V |
| Alternator | three-phase current 28 V/140 A |



Cooling System

| | |
|-----------------------|---|
| Electric motor | air-cooled cooling system for hydraulic oil with an infinitely variable, thermostatically controlled fan drive system |
|-----------------------|---|



Hydraulic Controls

| | |
|-----------------------------|--|
| Power distribution | via control valves with integrated safety valves, simultaneous and independent actuation of chassis, swing drive and equipment |
| Servo circuit | |
| Equipment and swing | with hydraulic pilot control and proportional joystick levers |
| Chassis | with hydraulic proportionally functioning foot pedals or adjusted with plugable levers |
| Additional functions | via switch or electro-proportional foot pedals |
| Proportional control | proportionally acting transmitters on the joysticks for additional hydraulic functions |



Hydraulic System

| | | |
|--|--------------------------------|---|
| Hydraulic pump | for equipment and travel drive | Liebherr axial piston variable displacement pump |
| Max. flow | | 103 gpm |
| Max. pressure | | 5,076 psi |
| Hydraulic pump regulation and control | | Liebherr-Synchron-Comfort-system (LSC) with electronic engine speed sensing regulation, pressure and flow compensation, torque controlled swing drive priority |
| Hydraulic tank | | 41 gal |
| Hydraulic system | | 93 gal |
| Hydraulic oil filter | | 1 main return filter with integrated partial micro filtration (5 µm) |
| MODE selection | | adjustment of engine and hydraulic performance via a mode pre-selector to match application, e.g. for especially economical and environmentally friendly operation or for maximum material handling and heavy-duty jobs |
| S (Sensitive) | | mode for precision work and lifting through very sensitive movements |
| E (Eco) | | mode for especially economical and environmentally friendly operation |
| P (Power) | | mode for high performance with low fuel consumption |
| P+ (Power-Plus) | | mode for highest performance and for very heavy duty applications, suitable for continuous operation |
| Engine speed and performance setting | | stepless alignment of engine output and hydraulic power via engine speed |
| Option | | Tool Control: 20 preadjustable pump flows and pressures for add-on attachments |



Swing Drive

| | |
|----------------------|--|
| Drive | Liebherr axial piston motor with integrated brake valve and torque control |
| Swing ring | Liebherr, sealed race ball bearing swing ring, internal teeth |
| Swing speed | 0 – 9,0 rpm stepless |
| Swing torque | 39,091 lbf ft |
| Holding brake | wet multi-disc (spring applied, pressure released) |
| Option | slewing gear brake Comfort |



Operator's Cab

| | |
|---|--|
| Cab | TOPS safety cab structure (tip-over protection) with individual windscreens or featuring a slide-in subpart under the ceiling, work headlights integrated in the ceiling, a door with a sliding window (can be opened on both sides), large stowing and depositing possibilities, shock-absorbing suspension, sound damping insulating, tinted laminated safety glass, separate shades for the sunroof window and windscreen |
| Operator's seat Comfort | air cushioned operator's seat with 3D-adjustable armrests, headrest, lap belt, seat heater, adjustable seat cushion inclination and length, lockable horizontal suspension, automatic weight adjustment, adjustable suspension stiffness, pneumatic lumbar vertebrae support and passive seat climatisation with active coal |
| Operator's seat Premium (Option) | in addition to operator's seat comfort: active electronic weight adjustment (automatic re-adjustment), pneumatic low frequency suspension and active seat climatisation with active coal and ventilator |
| Control system | joysticks with control consoles and swivel seat, folding left control console |
| Operation and displays | large high-resolution operating unit, self-explanatory, color display with touchscreen, video-compatible, numerous setting, control and monitoring options, e.g. air conditioning control, energy consumption, machine and attachment parameters |
| Air-conditioning | automatic air-conditioning, recirculated air function, fast de-icing and demisting at the press of a button, air vents can be operated via a menu; recirculated air and fresh air filters can be easily replaced and are accessible from the outside; heating-cooling unit, designed for extreme outside temperatures, sensors for solar radiation, inside and outside temperatures, stationary air conditioning function with external climate condenser – controlled by a weekly timer |



Undercarriage

| | |
|-------------------------|---|
| Mobile | |
| Drive | oversized two speed power shift transmission with additional creeper speed, Liebherr axial piston motor with functional brake valve on both sides |
| Travel speed | |
| Joystick steering | 0 – 2.0 mph stepless (creeper speed + transmission stage 1) |
| Wheel steering (Option) | 0 – 2.0 mph stepless (creeper speed + transmission stage 1) |
| Driving operation | automotive driving using accelerator pedal, cruise control function: storage of variable accelerator pedal positions |
| Axles | 88,185 lb drive axles; manual or automatic hydraulically controlled front axle oscillation lock |
| Service brake | two circuit travel brake system with accumulator; wet and backlash-free disc brake |
| Holding brake | wet multi-disc (spring applied, pressure released) |
| Stabilization | stabilizing blade + 2 point outriggers 4 point outriggers |
| Crawler | |
| Version | LC |
| Drive | Liebherr compact planetary reduction gear with Liebherr axial piston motor per side of undercarriage |
| Travel speed | 0 – 2.0 mph stepless (creeper speed) |
| Brake | functional brake valves on both sides |
| Holding brake | wet multi-disc (spring applied, pressure released) |
| Track pads | triple grouser |



Equipment

| | |
|----------------------------|---|
| Type | high-strength steel plates at high stressed points for the toughest requirements. Complex and stable mountings of equipment and cylinders |
| Hydraulic cylinders | Liebherr cylinders with special sealing and guide system and, depending on cylinder type, shock absorption |
| Bearings | sealed, low maintenance |



Complete Machine

| | | |
|-----------------------|--|------------|
| Lubrication | Liebherr central lubrication system for upper-carriage and equipment, automatically | |
| Steps system | safe and durable access system with anti-slip steps; main components hot-galvanized | |
| Noise emission | | |
| ISO 6396 | L _{PA} (inside cab) | = 70 dB(A) |
| 2000/14/EC | L _{WA} (surround noise) | = 99 dB(A) |

LH 26 M – Dimensions

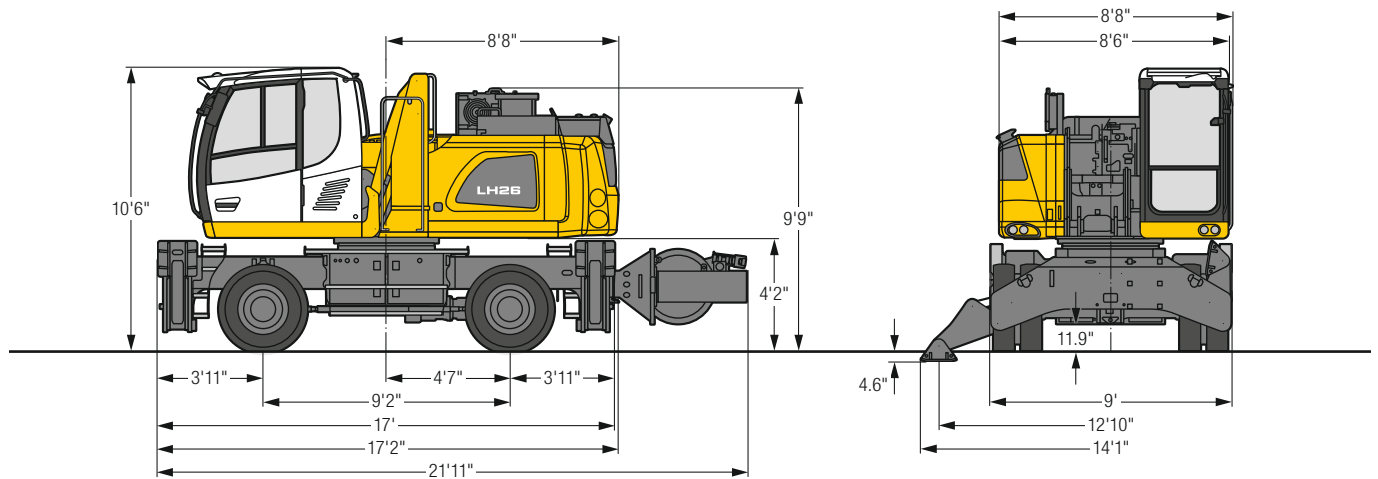

LH 26 M – Choice of Cab Elevation

**Cab Elevation LFC 120
(Rigid Elevation)**

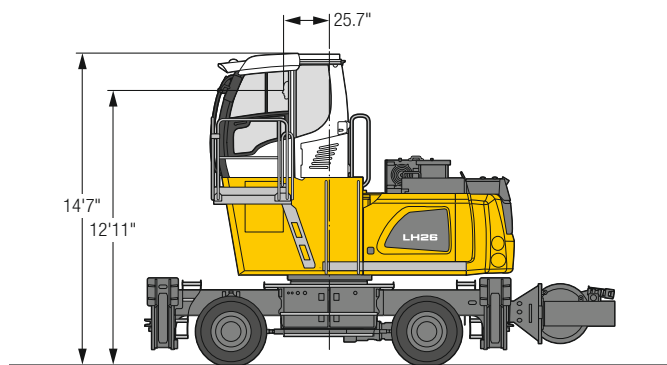

A rigid cab elevation has a fixed eye level height. For a lower transport height, the shell of the cab can be removed and replaced by a transport device. The dimension 14'7" is in this machine design for all rigid cab elevations 11'8".

**Cab Elevation LHC 255
(Hydraulic Elevation)**

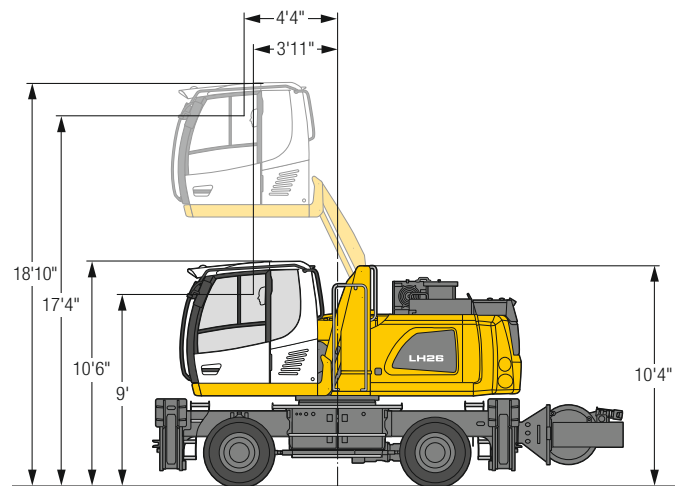

The hydraulically adjustable cab allows the driver, that he can choose his field of view freely and at any time within the stroke.

Tires 10.00-20

LH 26 C – Dimensions

Trailing cable

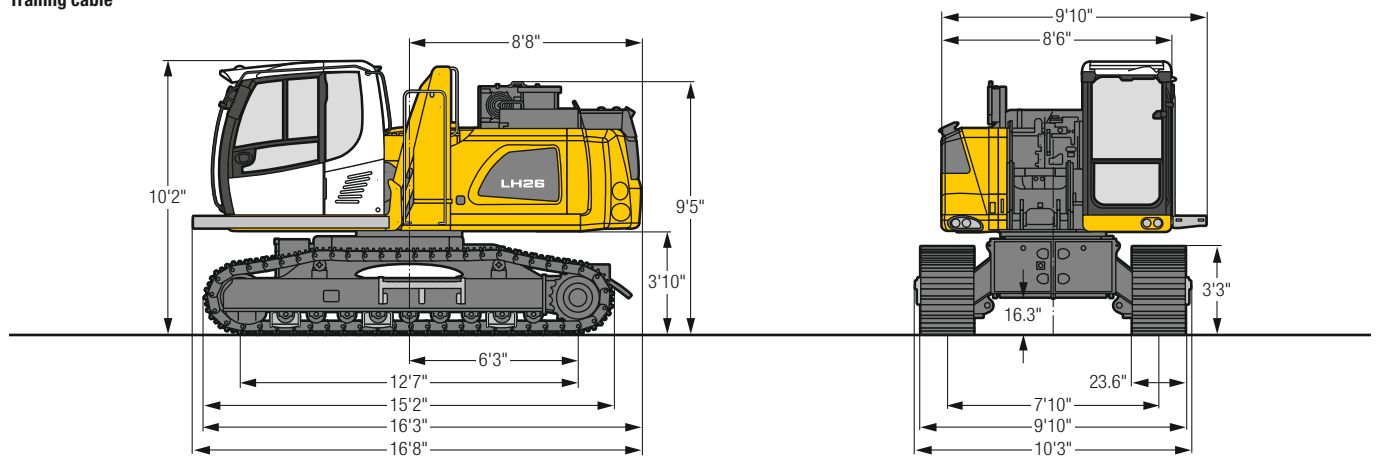

Cable reel system

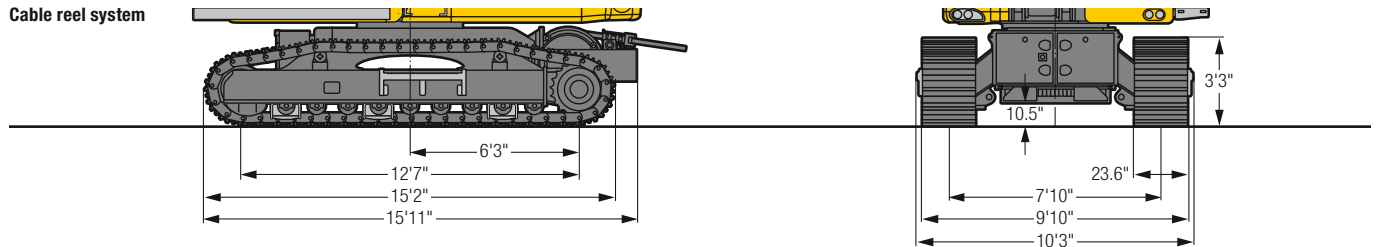

LH 26 C – Choice of Cab Elevation

Cab Elevation LFC 120 (Rigid Elevation)

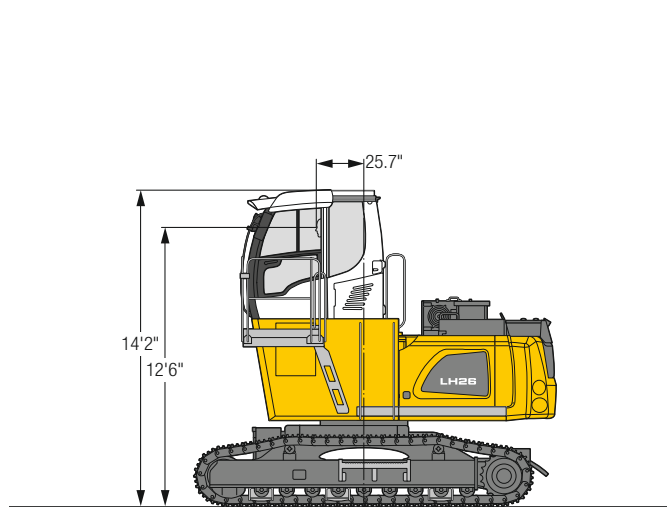

A rigid cab elevation has a fixed eye level height. For a lower transport height, the shell of the cab can be removed and replaced by a transport device. The dimension 14'2" mm is in this machine design for all rigid cab elevations 11'3".

Cab Elevation LHC 255 (Hydraulic Elevation)

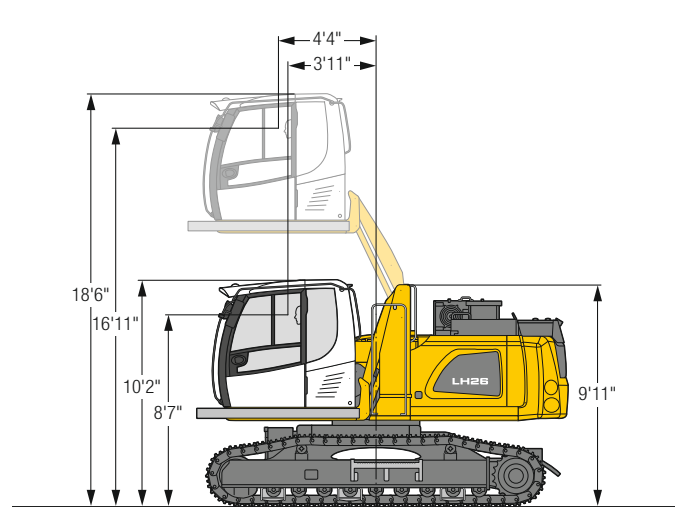

The hydraulically adjustable cab allows the driver, that he can choose his field of view freely and at any time within the stroke.

LH 26 M – Equipment GA12

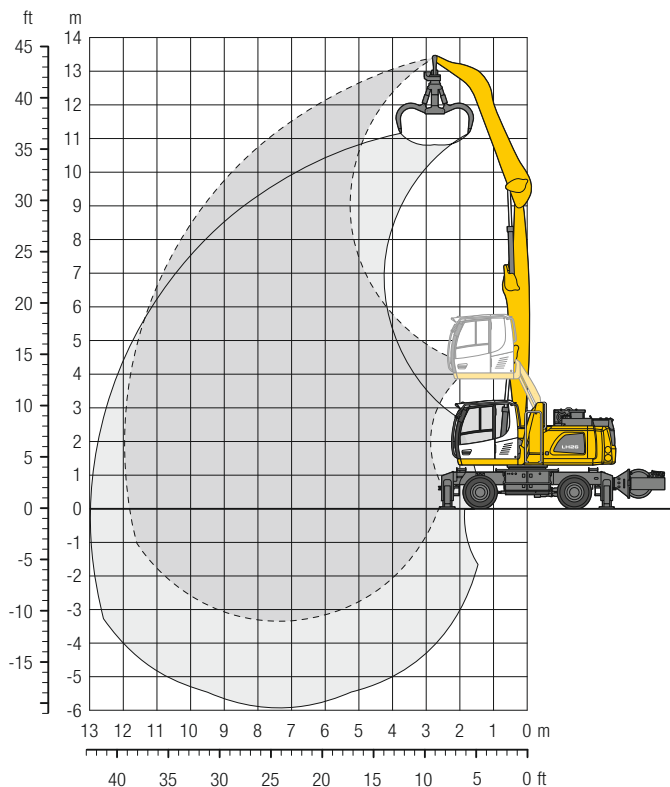

Operating Weight

The operating weight includes the basic machine with 4 point outriggers, hydr. cab elevation, 8 solid tires plus intermediate rings, straight boom 23'4", angled stick 16'5" and multi-tine grab GM 65/0.78 yd³ semi-closed tines.

Weight 59,800 lb

Dimensions

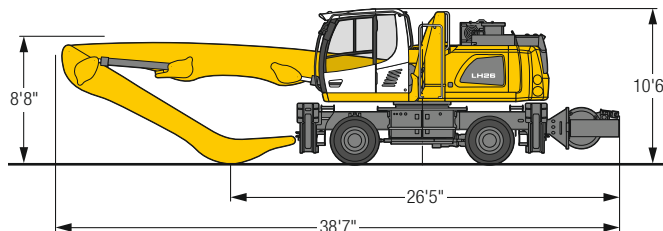

| ft | Undercarriage | 10 ft | | 15 ft | | 20 ft | | 25 ft | | 30 ft | | 35 ft | | 40 ft | | ft in |
|-----|-----------------------|--------------------|-----------------------|--------------------|-----------------------|--------------------|-----------------------|--------------------|-----------------------|--------------------|-----------------------|--------------------|-----------------------|--------------------|-----------------------|-------|
| | | Stabilizers raised | 4 pt. outriggers down | Stabilizers raised | 4 pt. outriggers down | Stabilizers raised | 4 pt. outriggers down | Stabilizers raised | 4 pt. outriggers down | Stabilizers raised | 4 pt. outriggers down | Stabilizers raised | 4 pt. outriggers down | Stabilizers raised | 4 pt. outriggers down | |
| 45 | Stabilizers raised | | | | | | | | | | | | | | | |
| 45 | 4 pt. outriggers down | | | | | | | | | | | | | | | |
| 40 | Stabilizers raised | | | 14,0* | 14,0* | | | | | | | | | | 10,4* | 10,4* |
| 40 | 4 pt. outriggers down | | | 14,0* | 14,0* | | | | | | | | | | 10,4* | 10,4* |
| 35 | Stabilizers raised | | | | | 11,4 | 13,6* | 7,8 | 10,4 | | | | | | 6,9 | 8,7* |
| 35 | 4 pt. outriggers down | | | | | 13,6* | 13,6* | 10,6* | 10,6* | | | | | | 8,7* | 8,7* |
| 30 | Stabilizers raised | | | | | 11,5 | 14,8* | 8,0 | 10,6 | 5,7 | 7,7 | | | | 5,2 | 7,1 |
| 30 | 4 pt. outriggers down | | | | | 14,8* | 14,8* | 12,9* | 12,9* | 9,6* | 9,6* | | | | 7,9* | 7,9* |
| 25 | Stabilizers raised | | | | | 11,4 | 15,0* | 7,9 | 10,5 | 5,7 | 7,8 | | | | 4,3 | 6,0 |
| 25 | 4 pt. outriggers down | | | | | 15,0* | 15,0* | 12,9* | 12,9* | 11,3* | 11,3* | | | | 7,5* | 7,5* |
| 20 | Stabilizers raised | | | 17,0* | 17,0* | 10,9 | 14,6 | 7,6 | 10,3 | 5,6 | 7,6 | 4,2 | 5,8 | | 3,8 | 5,3 |
| 20 | 4 pt. outriggers down | | | 17,0* | 17,0* | 15,7* | 15,7* | 13,2* | 13,2* | 11,4* | 11,4* | 9,0 | 9,8* | | 7,4* | 7,4* |
| 15 | Stabilizers raised | 18,2* | 18,2* | 15,8 | 21,5* | 10,2 | 13,9 | 7,2 | 9,8 | 5,4 | 7,4 | 4,1 | 5,7 | | 3,4 | 4,9 |
| 15 | 4 pt. outriggers down | 18,2* | 18,2* | 21,5* | 21,5* | 16,7* | 16,7* | 13,7* | 13,7* | 11,3 | 11,5* | 8,9 | 9,7* | | 7,4* | 7,4* |
| 10 | Stabilizers raised | 11,1* | 11,1* | 13,9 | 19,8 | 9,3 | 12,9 | 6,7 | 9,3 | 5,1 | 7,1 | 3,9 | 5,6 | | 3,2 | 4,7 |
| 10 | 4 pt. outriggers down | 11,1* | 11,1* | 23,8* | 23,8* | 17,6* | 17,6* | 14,0* | 14,0* | 11,0 | 11,6* | 8,7 | 9,6* | | 7,3 | 7,5* |
| 5 | Stabilizers raised | 2,3* | 2,3* | 12,3 | 17,9 | 8,4 | 12,0 | 6,2 | 8,8 | 4,8 | 6,8 | 3,8 | 5,4 | | 3,2 | 4,6 |
| 5 | 4 pt. outriggers down | 2,3* | 2,3* | 20,3* | 20,3* | 17,9* | 17,9* | 13,9 | 14,0* | 10,7 | 11,3* | 8,5 | 9,2* | | 7,1* | 7,1* |
| 0 | Stabilizers raised | 3,5* | 3,5* | 11,3 | 12,1* | 7,8 | 11,3 | 5,9 | 8,4 | 4,6 | 6,5 | 3,7 | 5,3 | | 3,2 | 4,6 |
| 0 | 4 pt. outriggers down | 3,5* | 3,5* | 12,1* | 12,1* | 17,1* | 17,1* | 13,4* | 13,4* | 10,4 | 10,7* | 8,3* | 8,3* | | 6,3* | 6,3* |
| -5 | Stabilizers raised | | | 11,0 | 12,1* | 7,5 | 11,0 | 5,6 | 8,1 | 4,4 | 6,4 | 3,6 | 5,2 | | 3,4 | 4,9 |
| -5 | 4 pt. outriggers down | | | 12,1* | 12,1* | 15,0* | 15,0* | 11,9* | 11,9* | 9,4* | 9,4* | 6,9* | 6,9* | | 5,8* | 5,8* |
| -10 | Stabilizers raised | | | | | 7,4 | 10,9 | 5,6 | 8,1 | | | | | | 4,5 | 6,5 |
| -10 | 4 pt. outriggers down | | | | | 11,8* | 11,8* | 9,5* | 9,5* | | | | | | 7,5* | 7,5* |

Height **Can be slewed through 360°** **In longitudinal position of undercarriage** **Max. reach** * Limited by hydr. capacity

The lift capacities on the stick end without attachment are stated in lb x 1,000 and are valid on a firm, level supporting surface with blocked oscillating axle. These capacities can be slewed through 360° with the undercarriage in the transverse position. Capacities in the longitudinal position of the undercarriage (+/- 15°) are specified over the steering axle with the stabilizers raised and over the rigid axle with the stabilizers down. Indicated loads based on the ISO 10567 standard and do not exceed 75% of tipping or 87% of hydraulic capacity. The lift capacity of the unit is limited by its stability, the lifting capability of the hydraulic elements, or the maximum permissible lifting capacity of the load hook.

LH 26 M – Equipment GA13

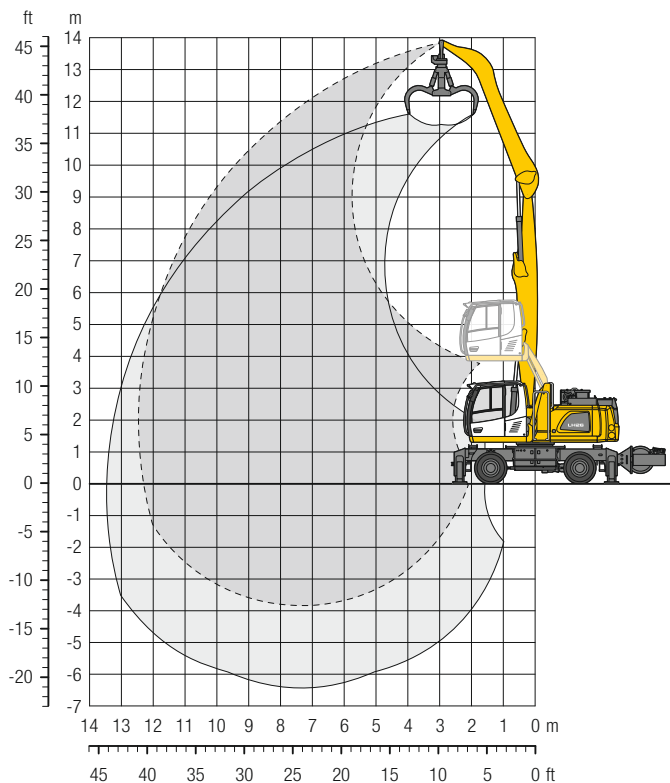

Operating Weight

The operating weight includes the basic machine with 4 point outriggers, hydr. cab elevation, 8 solid tires plus intermediate rings, straight boom 23'4", angled stick 18'1" and multi-tine grab GM 65/0.78 yd³ semi-closed tines.

Weight 60,000 lb

Dimensions

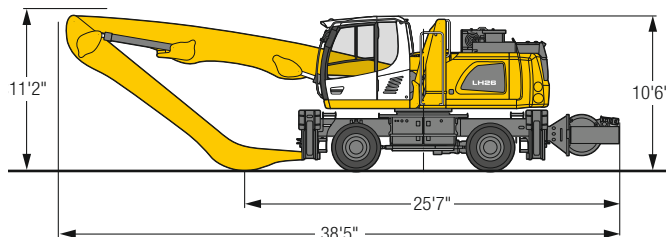

| ft | Undercarriage | 10 ft | | 15 ft | | 20 ft | | 25 ft | | 30 ft | | 35 ft | | 40 ft | | ft in | | | |
|-----|-----------------------|--------------------|-----------------------|--------------------|-----------------------|--------------------|-----------------------|--------------------|-----------------------|--------------------|-----------------------|--------------------|-----------------------|--------------------|-----------------------|--------------------|-----------------------|-------|--------|
| | | Stabilizers raised | 4 pt. outriggers down | Stabilizers raised | 4 pt. outriggers down | Stabilizers raised | 4 pt. outriggers down | Stabilizers raised | 4 pt. outriggers down | Stabilizers raised | 4 pt. outriggers down | Stabilizers raised | 4 pt. outriggers down | Stabilizers raised | 4 pt. outriggers down | Stabilizers raised | 4 pt. outriggers down | | |
| 45 | Stabilizers raised | | | | | | | | | | | | | | | | 13,1" | 13,1" | 11'11" |
| | 4 pt. outriggers down | | | | | | | | | | | | | | | | 13,1" | 13,1" | |
| 40 | Stabilizers raised | | | | | 11,2 | 11,2" | | | | | | | | | | 8,9 | 8,9" | 22'10" |
| | 4 pt. outriggers down | | | | | 11,2 | 11,2" | | | | | | | | | | 8,9 | 8,9" | |
| 35 | Stabilizers raised | | | | | 11,7 | 13,0" | 8,0 | 10,7 | | | | | | | | 6,0 | 7,7" | 29' |
| | 4 pt. outriggers down | | | | | 13,0 | 13,0" | 11,0 | 11,0" | | | | | | | | 7,7 | 7,7" | |
| 30 | Stabilizers raised | | | | | 11,8 | 13,7" | 8,2 | 10,8 | 5,9 | 7,9 | | | | | | 4,7 | 6,5 | 33' 4" |
| | 4 pt. outriggers down | | | | | 13,7 | 13,7" | 12,4 | 12,4" | 10,3 | 10,3" | | | | | | 7,1 | 7,1" | |
| 25 | Stabilizers raised | | | | | 11,7 | 14,4" | 8,1 | 10,7 | 5,8 | 7,9 | 4,3 | 6,0 | | | | 3,9 | 5,5 | 36' 5" |
| | 4 pt. outriggers down | | | | | 14,4 | 14,4" | 12,5 | 12,5" | 11,0 | 11,0" | 8,6 | 8,6" | | | | 6,7 | 6,7" | |
| 20 | Stabilizers raised | | | | | 11,2 | 15,0 | 7,8 | 10,4 | 5,7 | 7,7 | 4,3 | 5,9 | | | | 3,5 | 4,9 | 38' 6" |
| | 4 pt. outriggers down | | | | | 15,0 | 15,0" | 12,8 | 12,8" | 11,1 | 11,1" | 9,1 | 9,7" | | | | 6,6 | 6,6" | |
| 15 | Stabilizers raised | | | 16,4 | 17,7" | 10,5 | 14,2 | 7,4 | 10,0 | 5,4 | 7,5 | 4,1 | 5,8 | | | | 3,2 | 4,6 | 40' |
| | 4 pt. outriggers down | | | 17,7 | 17,7" | 16,1 | 16,1" | 13,3 | 13,3" | 11,3 | 11,3" | 8,9 | 9,7" | | | | 6,6 | 6,6" | |
| 10 | Stabilizers raised | 26,6 | 35,5" | 14,5 | 20,4 | 9,5 | 13,2 | 6,8 | 9,4 | 5,1 | 7,1 | 4,0 | 5,6 | 3,1 | 4,5 | | 3,0 | 4,3 | 40' 8" |
| | 4 pt. outriggers down | 35,5 | 35,5" | 23,0 | 23,0" | 17,2 | 17,2" | 13,8 | 13,8" | 11,1 | 11,5" | 8,7 | 9,6" | 7,1 | 7,7" | | 6,7 | 6,7" | |
| 5 | Stabilizers raised | 3,8 | 3,8" | 12,6 | 18,3 | 8,6 | 12,2 | 6,3 | 8,9 | 4,8 | 6,8 | 3,8 | 5,4 | 3,0 | 4,4 | | 2,9 | 4,3 | 40'11" |
| | 4 pt. outriggers down | 3,8 | 3,8" | 24,4 | 24,4" | 17,8 | 17,8" | 14,0 | 14,0" | 10,7 | 11,4" | 8,5 | 9,3" | 7,0 | 7,2" | | 6,7 | 6,7" | |
| 0 | Stabilizers raised | 3,9 | 3,9" | 11,4 | 13,7" | 7,9 | 11,4 | 5,9 | 8,4 | 4,5 | 6,5 | 3,6 | 5,2 | 3,0 | 4,3 | | 2,9 | 4,3 | 40' 4" |
| | 4 pt. outriggers down | 3,9 | 3,9" | 13,7 | 13,7" | 17,4 | 17,4" | 13,5 | 13,6" | 10,4 | 10,9" | 8,4 | 8,7" | 6,2 | 6,2" | | 6,0 | 6,0" | |
| -5 | Stabilizers raised | 5,7 | 5,7" | 10,9 | 12,3" | 7,4 | 10,9 | 5,6 | 8,1 | 4,4 | 6,3 | 3,5 | 5,1 | | | | 3,1 | 4,5 | 38'10" |
| | 4 pt. outriggers down | 5,7 | 5,7" | 12,3 | 12,3" | 15,7 | 15,7" | 12,4 | 12,4" | 9,8 | 9,8" | 7,5 | 7,5" | | | | 5,4 | 5,4" | |
| -10 | Stabilizers raised | | | 10,8 | 13,4" | 7,3 | 10,8 | 5,4 | 8,0 | 4,3 | 6,3 | | | | | | 3,8 | 5,5 | 33' 4" |
| | 4 pt. outriggers down | | | 13,4 | 13,4" | 12,9 | 12,9" | 10,3 | 10,3" | 8,0 | 8,0" | | | | | | 6,4 | 6,4" | |

Height Can be slewed through 360° In longitudinal position of undercarriage Max. reach * Limited by hydr. capacity

The lift capacities on the stick end without attachment are stated in lb x 1,000 and are valid on a firm, level supporting surface with blocked oscillating axle. These capacities can be slewed through 360° with the undercarriage in the transverse position. Capacities in the longitudinal position of the undercarriage (+/- 15°) are specified over the steering axle with the stabilizers raised and over the rigid axle with the stabilizers down. Indicated loads based on the ISO 10567 standard and do not exceed 75% of tipping or 87% of hydraulic capacity. The lift capacity of the unit is limited by its stability, the lifting capability of the hydraulic elements, or the maximum permissible lifting capacity of the load hook.

LH 26 M – Equipment GK11

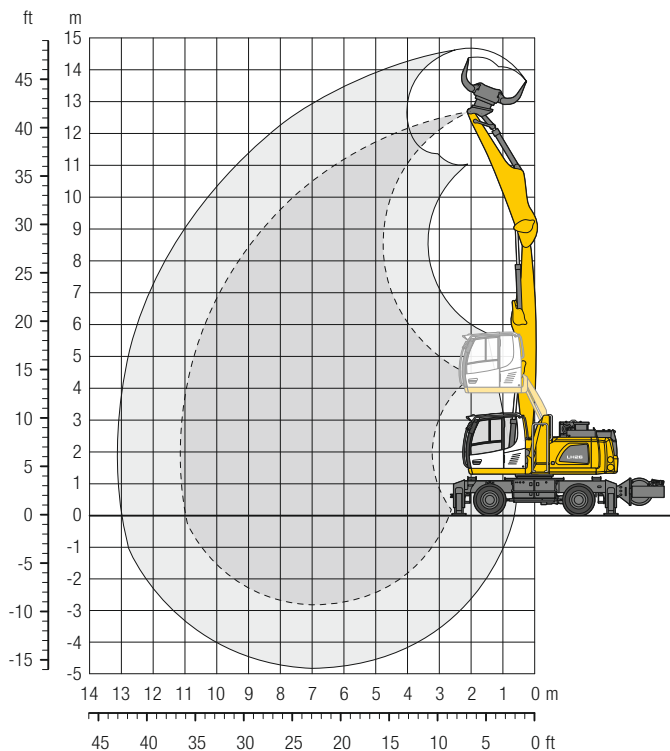

Operating Weight

The operating weight includes the basic machine with 4 point outriggers, hydr. cab elevation, 8 solid tires plus intermediate rings, straight boom 21'8", stick with tipping kinematics 14'9" and sorting grab SG 25B/0.72 yd³ perforated shells.

Weight 59,500 lb

Dimensions

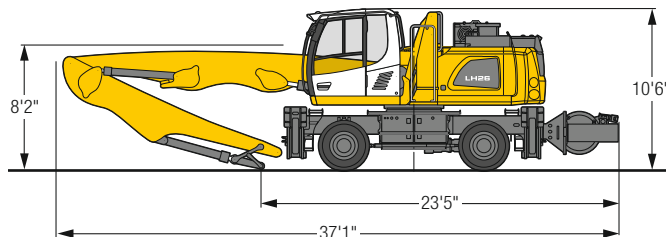

| ft | Undercarriage | 10 ft | | 15 ft | | 20 ft | | 25 ft | | 30 ft | | 35 ft | | 40 ft | | ft in | | |
|----|-----------------------|-------|-------|-------|-------|-------|-------|-------|-------|-------|-------|-------|------|-------|--|-------|-------|--------|
| | | | | | | | | | | | | | | | | | | |
| 40 | Stabilizers raised | 18,4* | 18,4* | | | | | | | | | | | | | 14,9* | 14,9* | 13' 4" |
| | 4 pt. outriggers down | 18,4* | 18,4* | | | | | | | | | | | | | 14,9* | 14,9* | |
| 35 | Stabilizers raised | | | 16,5* | 16,5* | 10,4 | 13,5* | | | | | | | | | 8,3 | 10,4* | 22' 5" |
| | 4 pt. outriggers down | | | 16,5* | 16,5* | 13,5* | 13,5* | | | | | | | | | 10,4* | 10,4* | |
| 30 | Stabilizers raised | | | | | 10,7 | 14,4 | 7,2 | 9,8 | | | | | | | 5,7 | 8,0 | 27'10" |
| | 4 pt. outriggers down | | | | | 15,1* | 15,1* | 12,9* | 12,9* | | | | | | | 8,9* | 8,9* | |
| 25 | Stabilizers raised | | | | | 10,7 | 14,4 | 7,2 | 9,9 | 5,1 | 7,1 | | | | | 4,5 | 6,4 | 31' 5" |
| | 4 pt. outriggers down | | | | | 15,1* | 15,1* | 12,9* | 12,9* | 11,0 | 11,0* | | | | | 8,2* | 8,2* | |
| 20 | Stabilizers raised | | | 16,5 | 17,4* | 10,3 | 14,0 | 7,1 | 9,7 | 5,0 | 7,0 | | | | | 3,9 | 5,6 | 33'11" |
| | 4 pt. outriggers down | | | 17,4* | 17,4* | 15,6* | 15,6* | 13,1* | 13,1* | 11,0 | 11,2* | | | | | 7,8* | 7,8* | |
| 15 | Stabilizers raised | 15,6* | 15,6* | 15,3 | 21,3 | 9,7 | 13,3 | 6,7 | 9,3 | 4,9 | 6,9 | 3,6 | 5,2 | | | 3,5 | 5,1 | 35' 7" |
| | 4 pt. outriggers down | 15,6* | 15,6* | 21,5* | 21,5* | 16,6* | 16,6* | 13,5* | 13,5* | 10,8 | 11,2* | 8,3 | 9,1* | | | 7,7* | 7,7* | |
| 10 | Stabilizers raised | 7,9* | 7,9* | 13,6 | 19,5 | 8,9 | 12,5 | 6,3 | 8,9 | 4,7 | 6,6 | 3,5 | 5,1 | | | 3,2 | 4,8 | 36' 5" |
| | 4 pt. outriggers down | 7,9* | 7,9* | 23,7* | 23,7* | 17,5* | 17,5* | 13,8* | 13,8* | 10,5 | 11,2* | 8,2 | 8,8* | | | 7,7 | 7,8* | |
| 5 | Stabilizers raised | | | 12,1 | 17,8 | 8,2 | 11,7 | 5,9 | 8,4 | 4,4 | 6,4 | 3,4 | 5,0 | | | 3,2 | 4,7 | 36' 6" |
| | 4 pt. outriggers down | | | 23,3* | 23,3* | 17,7* | 17,7* | 13,6 | 13,7* | 10,3 | 10,8* | 8,1 | 8,1* | | | 7,0* | 7,0* | |
| 0 | Stabilizers raised | 2,5* | 2,5* | 11,3 | 13,2* | 7,6 | 11,1 | 5,6 | 8,1 | 4,3 | 6,2 | 3,4 | 5,0 | | | 3,2 | 4,8 | 36' |
| | 4 pt. outriggers down | 2,5* | 2,5* | 13,2* | 13,2* | 16,7* | 16,7* | 12,8* | 12,8* | 9,9* | 9,9* | 6,8* | 6,8* | | | 5,9* | 5,9* | |
| -5 | Stabilizers raised | | | 11,0 | 13,9* | 7,4 | 10,9 | 5,4 | 7,9 | 4,2 | 6,1 | | | | | 3,7 | 5,4 | 32'10" |
| | 4 pt. outriggers down | | | 13,9* | 13,9* | 14,3* | 14,3* | 11,0* | 11,0* | 8,1* | 8,1* | | | | | 6,3* | 6,3* | |

Height Can be slewed through 360° In longitudinal position of undercarriage Max. reach * Limited by hydr. capacity

The lift capacities on the stick end without attachment are stated in lb x 1,000 and are valid on a firm, level supporting surface with blocked oscillating axle. These capacities can be slewed through 360° with the undercarriage in the transverse position. Capacities in the longitudinal position of the undercarriage (+/- 15°) are specified over the steering axle with the stabilizers raised and over the rigid axle with the stabilizers down. Indicated loads based on the ISO 10567 standard and do not exceed 75% of tipping or 87% of hydraulic capacity. The lift capacity of the unit is limited by its stability, the lifting capability of the hydraulic elements, or the maximum permissible lifting capacity of the load hook.

LH 26 M – Equipment VK9

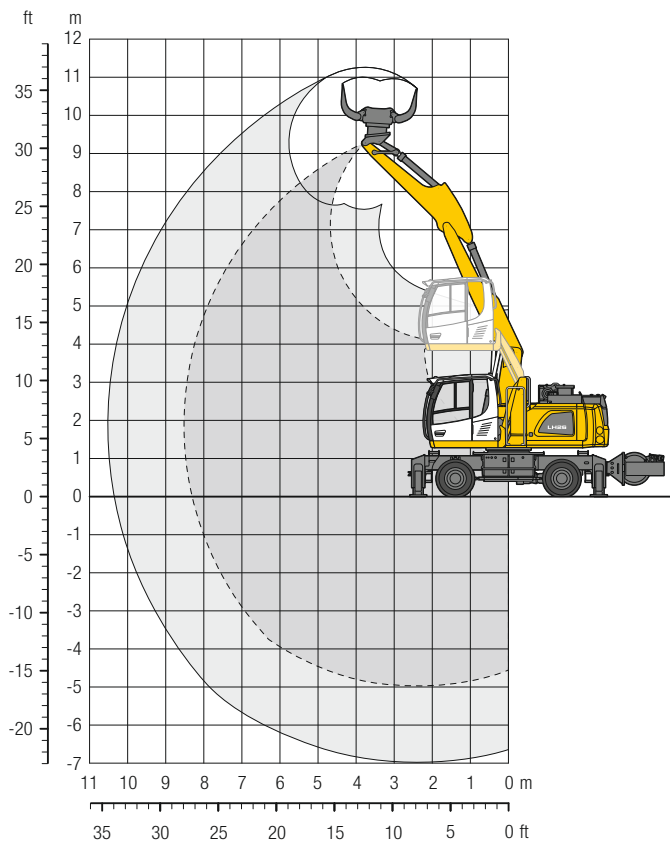

Operating Weight

The operating weight includes the basic machine with 4 point outriggers, hydr. cab elevation, 8 solid tires plus intermediate rings, two-piece boom 17'9" (HD), stick with tipping kinematics 10' and sorting grab SG 25B/0.72 yd³ perforated shells.

Weight 59,500 lb

Dimensions

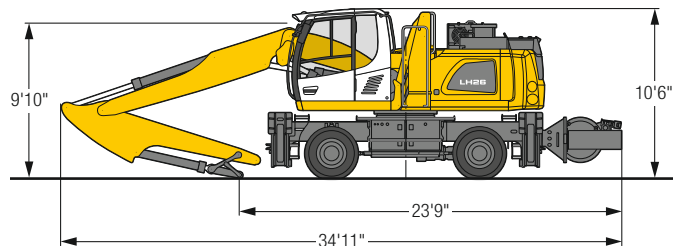

| ft | Undercarriage | 10 ft | | 15 ft | | 20 ft | | 25 ft | | 30 ft | | 35 ft | | 40 ft | | ft in | | | |
|-----|-----------------------|--------------------|-----------------------|--------------------|-----------------------|--------------------|-----------------------|--------------------|-----------------------|--------------------|-----------------------|--------------------|-----------------------|--------------------|-----------------------|--------------------|-----------------------|-------|--------|
| | | Stabilizers raised | 4 pt. outriggers down | Stabilizers raised | 4 pt. outriggers down | Stabilizers raised | 4 pt. outriggers down | Stabilizers raised | 4 pt. outriggers down | Stabilizers raised | 4 pt. outriggers down | Stabilizers raised | 4 pt. outriggers down | Stabilizers raised | 4 pt. outriggers down | Stabilizers raised | 4 pt. outriggers down | | |
| 30 | Stabilizers raised | | | | | | | | | | | | | | | | 8,2" | 8,2" | 13' 6" |
| | 4 pt. outriggers down | | | | | | | | | | | | | | | | 8,2" | 8,2" | |
| 25 | Stabilizers raised | | | | | 7,1* | 7,1* | | | | | | | | | | 6,5" | 6,5" | 20' 4" |
| | 4 pt. outriggers down | | | | | 7,1* | 7,1* | | | | | | | | | | 6,5" | 6,5" | |
| 20 | Stabilizers raised | | | 11,0* | 11,0* | 10,7* | 10,7* | | | | | | | | | | 5,9" | 5,9" | 24' 2" |
| | 4 pt. outriggers down | | | 11,0* | 11,0* | 10,7* | 10,7* | | | | | | | | | | 5,9" | 5,9" | |
| 15 | Stabilizers raised | | | 13,6* | 13,6* | 10,9 | 12,8* | 7,5 | 9,2* | | | | | | | | 5,8" | 5,8" | 26' 6" |
| | 4 pt. outriggers down | | | 13,6* | 13,6* | 12,8* | 12,8* | 9,2* | 9,2* | | | | | | | | 5,8" | 5,8" | |
| 10 | Stabilizers raised | 27,8 | 30,3* | 15,7 | 19,1* | 10,7 | 13,8 | 7,4 | 9,9 | | | | | | | | 5,9" | 5,9" | 27' 8" |
| | 4 pt. outriggers down | 30,3* | 30,3* | 19,1* | 19,1* | 14,6* | 14,6* | 12,0* | 12,0* | | | | | | | | 5,9" | 5,9" | |
| 5 | Stabilizers raised | 27,2 | 28,7* | 15,4 | 20,3 | 10,6 | 13,7 | 7,3 | 9,8 | | | | | | | | 5,9 | 6,3" | 27'11" |
| | 4 pt. outriggers down | 28,7* | 28,7* | 21,8* | 21,8* | 15,8* | 15,8* | 12,6* | 12,6* | | | | | | | | 6,3" | 6,3" | |
| 0 | Stabilizers raised | 27,3 | 32,1* | 15,5 | 20,3 | 10,3 | 13,8 | 7,0 | 9,5 | | | | | | | | 6,0 | 7,0" | 27' 2" |
| | 4 pt. outriggers down | 32,1* | 32,1* | 22,4* | 22,4* | 16,2* | 16,2* | 12,7* | 12,7* | | | | | | | | 7,0* | 7,0* | |
| -5 | Stabilizers raised | 27,1 | 36,2* | 15,0 | 20,7 | 9,7 | 13,3 | 6,7 | 9,3 | | | | | | | | 6,5 | 8,3" | 25' 6" |
| | 4 pt. outriggers down | 36,2* | 36,2* | 22,7* | 22,7* | 16,5* | 16,5* | 11,2* | 11,2* | | | | | | | | 8,3" | 8,3" | |
| -10 | Stabilizers raised | 26,6 | 37,4* | 14,3 | 20,2 | 9,2 | 12,8 | | | | | | | | | | 7,7 | 9,8" | 22' 6" |
| | 4 pt. outriggers down | 37,4* | 37,4* | 23,4* | 23,4* | 14,7* | 14,7* | | | | | | | | | | 9,8" | 9,8" | |
| -15 | Stabilizers raised | 25,9 | 28,7* | 13,8* | 13,8* | | | | | | | | | | | | 13,5" | 13,5" | 15' 1" |
| | 4 pt. outriggers down | 28,7* | 28,7* | 13,8* | 13,8* | | | | | | | | | | | | 13,5" | 13,5" | |

Height Can be slewed through 360° In longitudinal position of undercarriage Max. reach * Limited by hydr. capacity

The lift capacities on the stick end without attachment are stated in lb x 1,000 and are valid on a firm, level supporting surface with blocked oscillating axle. These capacities can be slewed through 360° with the undercarriage in the transverse position. Capacities in the longitudinal position of the undercarriage (+/- 15°) are specified over the steering axle with the stabilizers raised and over the rigid axle with the stabilizers down. The values apply with the optimum positioning of the two-piece boom. Indicated loads based on the ISO 10567 standard and do not exceed 75% of tipping or 87% of hydraulic capacity. The lift capacity of the unit is limited by its stability, the lifting capability of the hydraulic elements, or the maximum permissible lifting capacity of the load hook.

LH 26 C – Equipment GA10

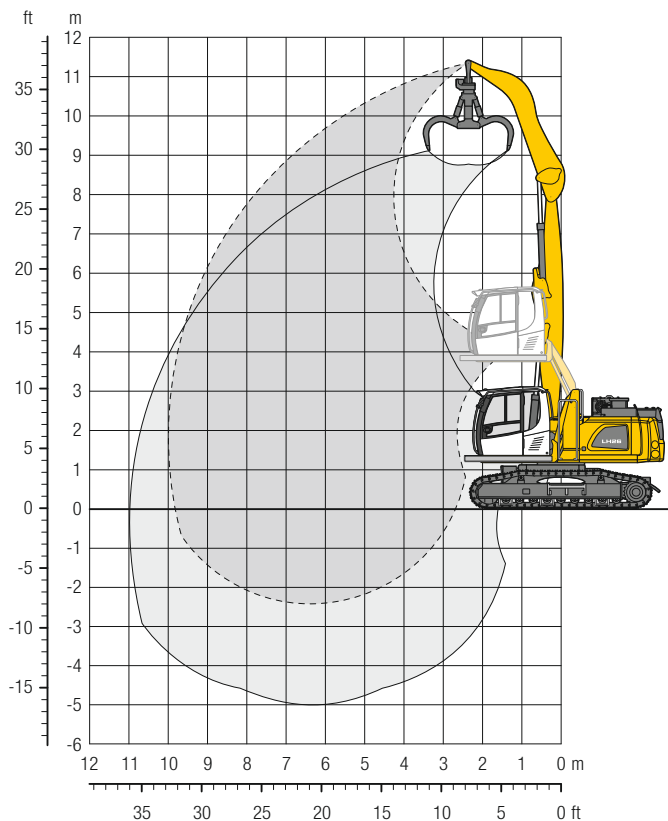

Operating Weight and Ground Pressure

The operating weight includes the basic machine with hydr. cab elevation, straight boom 20', angled stick 13'1" and multi-tine grab GM 65/0.78 yd³ semi-closed tines.

| | |
|-----------------|------------|
| Weight | 62,500 lb |
| Pad width | 24" |
| Ground pressure | on request |

Dimensions

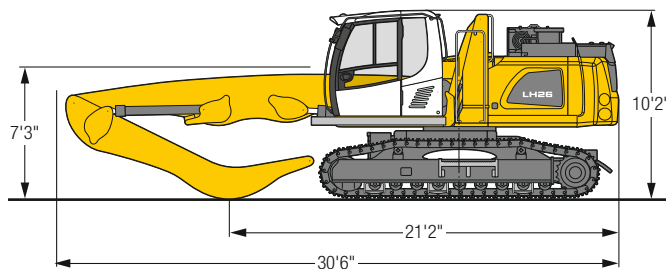

| ft | Undercarriage | 10 ft | | 15 ft | | 20 ft | | 25 ft | | 30 ft | | 35 ft | | 40 ft | | ft in | |
|-----|---------------|-------|----|-------|----|-------|----|-------|----|-------|----|-------|----|-------|----|-------|----|
| | | LC | LC | LC | LC | LC | LC | LC | LC | LC | LC | LC | LC | LC | LC | LC | LC |
| 40 | LC | | | | | | | | | | | | | | | | |
| 35 | LC | | | | | | | | | | | | | | | | |
| 30 | LC | | | | | | | | | | | | | | | | |
| 25 | LC | | | | | | | | | | | | | | | | |
| 20 | LC | | | | | | | | | | | | | | | | |
| 15 | LC | | | | | | | | | | | | | | | | |
| 10 | LC | | | | | | | | | | | | | | | | |
| 5 | LC | | | | | | | | | | | | | | | | |
| 0 | LC | | | | | | | | | | | | | | | | |
| -5 | LC | | | | | | | | | | | | | | | | |
| -10 | LC | | | | | | | | | | | | | | | | |

Height **Can be slewed through 360°** **In longitudinal position of undercarriage** **Max. reach** * **Limited by hydr. capacity**

The lift capacities on the stick end without attachment are stated in lb x 1,000 and can be slewed through 360° on a firm, level supporting surface. Capacities are valid for 30" wide triple grouser pads. Indicated loads based on the ISO 10567 standard and do not exceed 75% of tipping or 87% of hydraulic capacity. The lift capacity of the unit is limited by its stability, the lifting capability of the hydraulic elements, or the maximum permissible lifting capacity of the load hook.

LH 26 C – Equipment GA12

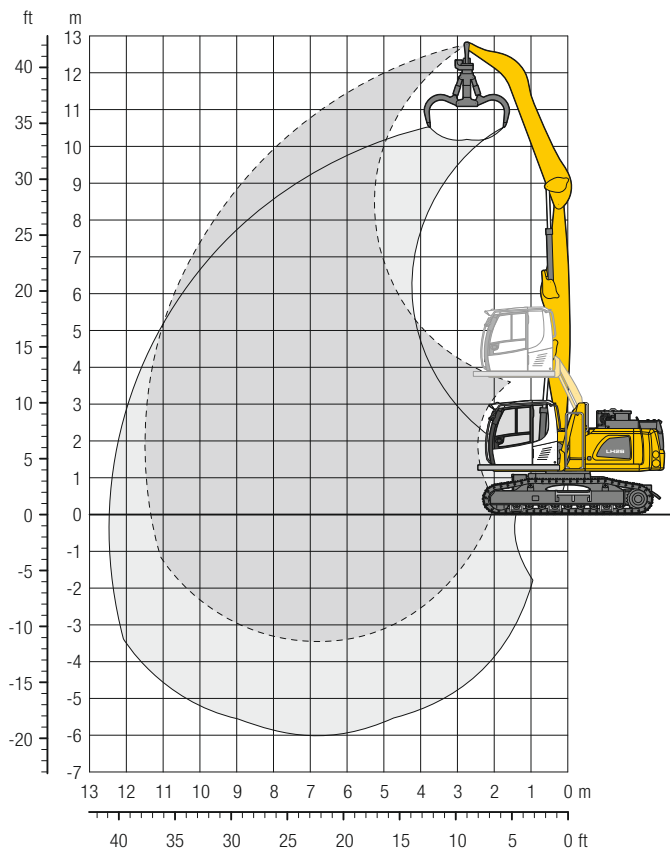

Operating Weight and Ground Pressure

The operating weight includes the basic machine with hydr. cab elevation, straight boom 21'8", angled stick 16'5" and multi-tine grab GM 65/0.78 yd³ semi-closed tines.

| | |
|-----------------|------------|
| Weight | 62,900 lb |
| Pad width | 24" |
| Ground pressure | on request |

Dimensions

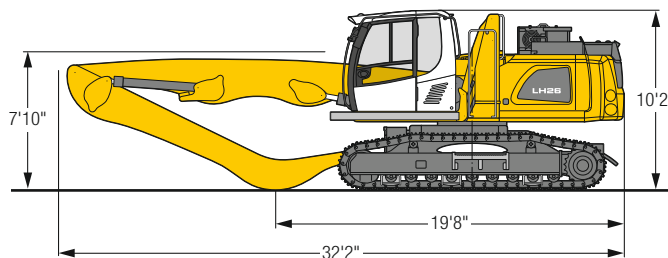

| ft | Undercarriage | 10 ft | | 15 ft | | 20 ft | | 25 ft | | 30 ft | | 35 ft | | 40 ft | | ft in | | |
|-----|---------------|-------|-------|-------|-------|-------|-------|-------|-------|-------|-------|-------|------|-------|--|-------|-------|--------|
| | | | | | | | | | | | | | | | | | | |
| 40 | LC | | | | | 12,5* | 12,5* | | | | | | | | | 12,1* | 12,1* | 14'11" |
| 35 | LC | | | | | | | | | | | | | | | 9,2* | 9,2* | 23' 6" |
| 30 | LC | | | | | 14,4* | 14,4* | 11,2 | 12,0* | | | | | | | 8,1* | 8,1* | 28' 8" |
| 25 | LC | | | | | 15,0* | 15,0* | 11,2 | 13,1* | 8,3 | 10,8* | | | | | 7,3 | 7,6* | 32' 5" |
| 20 | LC | | | | | 15,5* | 15,5* | 11,0 | 13,4* | 8,3 | 11,6* | | | | | 6,4 | 7,4* | 34'11" |
| 15 | LC | | | 19,4* | 19,4* | 15,0 | 16,5* | 10,7 | 13,8* | 8,1 | 11,7* | 6,3 | 9,6 | | | 5,9 | 7,3* | 36' 6" |
| 10 | LC | 35,5* | 35,5* | 21,6 | 23,4* | 14,1 | 17,6* | 10,2 | 14,2* | 7,8 | 11,8* | 6,2 | 9,5 | | | 5,6 | 7,5* | 37' 5" |
| 5 | LC | 5,8* | 5,8* | 19,8 | 25,0* | 13,3 | 18,3* | 9,8 | 14,4* | 7,6 | 11,6* | 6,1 | 9,3* | | | 5,5 | 7,7* | 37' 7" |
| 0 | LC | 5,1* | 5,1* | 18,7 | 19,3* | 12,6 | 17,9* | 9,4 | 13,9* | 7,4 | 11,0* | 6,0 | 8,4* | | | 5,5 | 6,9* | 37' 2" |
| -5 | LC | 7,1* | 7,1* | 16,1* | 16,1* | 12,3 | 16,1* | 9,1 | 12,6* | 7,2 | 9,7* | 5,9 | 6,7* | | | 5,8 | 6,3* | 35' 6" |
| -10 | LC | | | | | 12,1 | 12,9* | 9,1 | 10,1* | | | | | | | 7,5 | 7,9* | 29' |

Height Can be slewed through 360° In longitudinal position of undercarriage Max. reach * Limited by hydr. capacity

The lift capacities on the stick end without attachment are stated in lb x 1,000 and can be slewed through 360° on a firm, level supporting surface. Capacities are valid for 30" wide triple grouser pads. Indicated loads based on the ISO 10567 standard and do not exceed 75% of tipping or 87% of hydraulic capacity. The lift capacity of the unit is limited by its stability, the lifting capability of the hydraulic elements, or the maximum permissible lifting capacity of the load hook.

LH 26 C – Equipment GK11

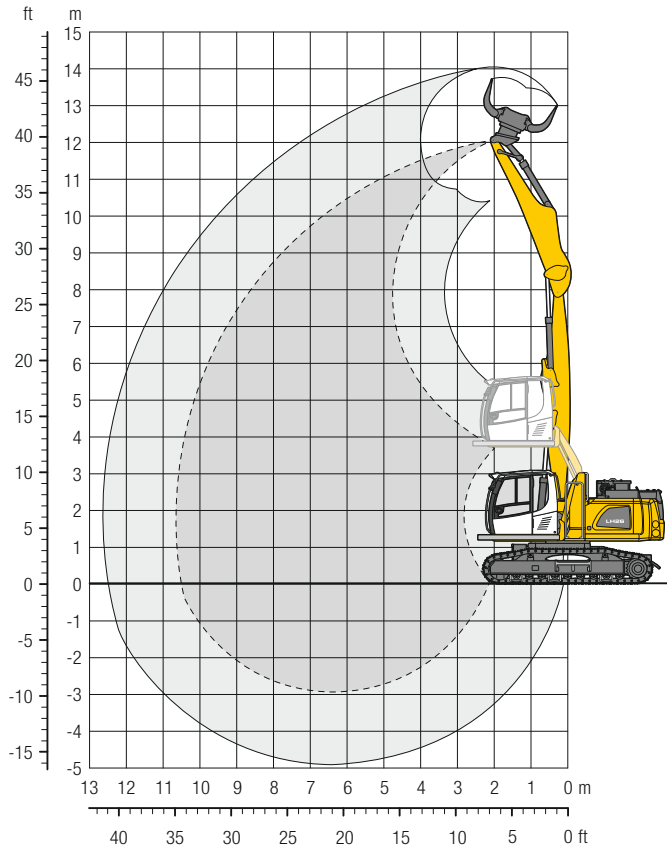

Operating Weight and Ground Pressure

The operating weight includes the basic machine with hydr. cab elevation, straight boom 20', stick with tipping kinematics 14'9" and sorting grab SG 25B/0.72 yd³ perforated shells.

| | |
|-----------------|------------|
| Weight | 63,000 lb |
| Pad width | 24" |
| Ground pressure | on request |

Dimensions

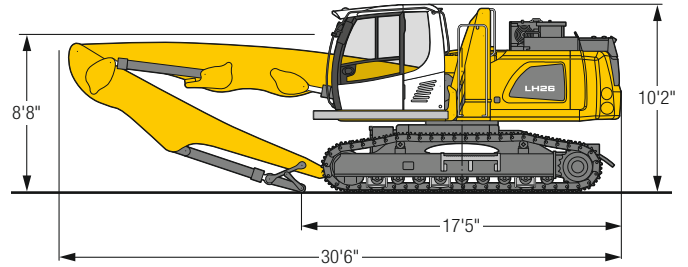

| ft | Undercarriage | 10 ft | | 15 ft | | 20 ft | | 25 ft | | 30 ft | | 35 ft | | 40 ft | | ft in | | |
|-----|---------------|-------|-------|-------|-------|-------|-------|-------|-------|-------|-------|-------|----|-------|----|-------|-------|--------|
| | | LC | LC | LC | LC | LC | LC | LC | LC | LC | LC | LC | LC | LC | LC | LC | LC | |
| 35 | LC | | | 15,7* | 15,7* | | | | | | | | | | | 11,5* | 11,5* | 18'10" |
| 30 | LC | | | | | 14,8* | 14,8* | 9,4* | 9,4* | | | | | | | 9,3* | 9,3* | 25' 1" |
| 25 | LC | | | | | 15,1 | 15,1* | 10,4 | 13,2* | | | | | | | 7,8 | 8,3* | 29' 2" |
| 20 | LC | | | 16,9* | 16,9* | 14,9 | 15,5* | 10,3 | 13,2* | 7,5 | 11,3* | | | | | 6,7 | 7,9* | 31'11" |
| 15 | LC | | | 19,3* | 19,3* | 14,3 | 16,3* | 10,1 | 13,5* | 7,4 | 11,3* | | | | | 6,0 | 7,7* | 33' 8" |
| 10 | LC | 35,2* | 35,2* | 21,1 | 23,1* | 13,6 | 17,3* | 9,7 | 13,8* | 7,3 | 11,2* | | | | | 5,7 | 7,7* | 34' 8" |
| 5 | LC | 4,2* | 4,2* | 19,4 | 24,6* | 12,8 | 17,8* | 9,3 | 13,8* | 7,0 | 10,9* | | | | | 5,6 | 7,6* | 34'11" |
| 0 | LC | 4,3* | 4,3* | 18,3 | 23,2* | 12,2 | 17,2* | 8,9 | 13,1* | 6,9 | 9,9* | | | | | 5,7 | 6,4* | 34' 5" |
| -5 | LC | | | 17,9 | 19,5* | 11,9 | 15,0* | 8,7 | 11,3* | 6,8 | 8,0* | | | | | 6,3 | 6,7* | 31' 7" |
| -10 | LC | | | | | | | | | | | | | | | | | |

Height **Can be slewed through 360°** **In longitudinal position of undercarriage** **Max. reach** * Limited by hydr. capacity

The lift capacities on the stick end without attachment are stated in lb x 1,000 and can be slewed through 360° on a firm, level supporting surface. Capacities are valid for 30" wide triple grouser pads. Indicated loads based on the ISO 10567 standard and do not exceed 75% of tipping or 87% of hydraulic capacity. The lift capacity of the unit is limited by its stability, the lifting capability of the hydraulic elements, or the maximum permissible lifting capacity of the load hook.

LH 26 C – Equipment VK9

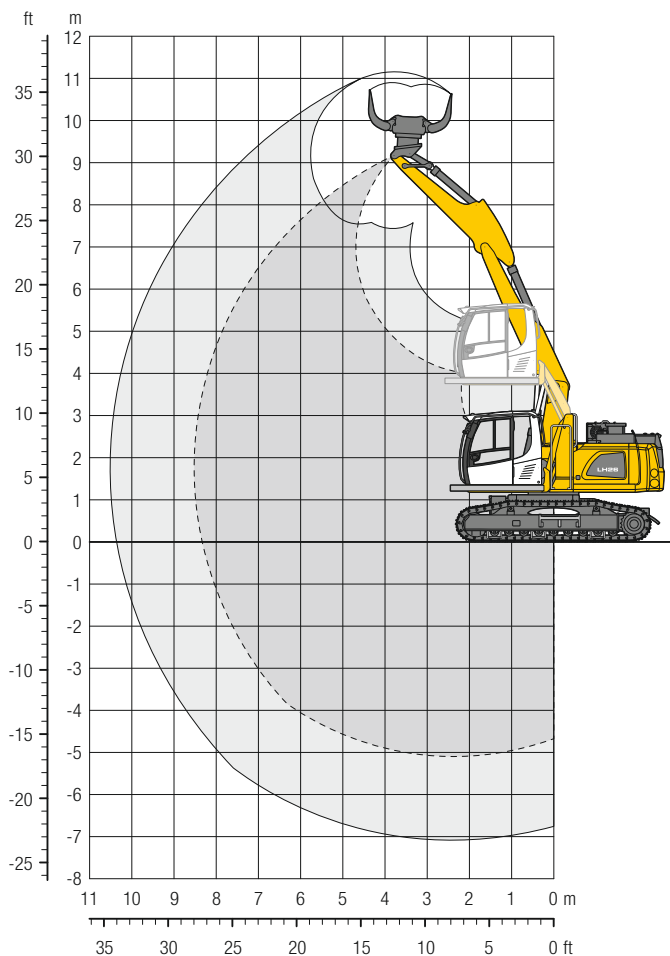

Operating Weight and Ground Pressure

The operating weight includes the basic machine with hydr. cab elevation, two-piece boom 17'9" (HD), stick with tipping kinematics 10' and sorting grab SG 25B/0.72 yd³ perforated shells.

| | |
|-----------------|------------|
| Weight | 63,000 lb |
| Pad width | 600 mm |
| Ground pressure | on request |

Dimensions

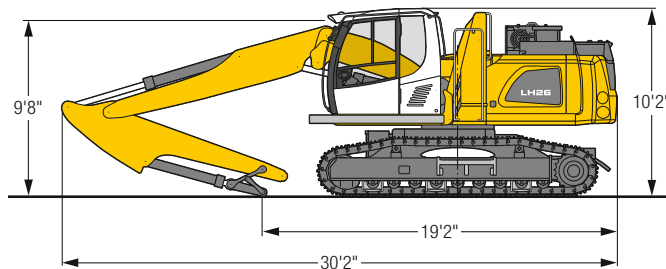

| ft | Undercarriage | 10 ft | | 15 ft | | 20 ft | | 25 ft | | 30 ft | | 35 ft | | 40 ft | | ft in | | | |
|-----|---------------|-------|-------|-------|-------|-------|-------|-------|-------|-------|--|-------|--|-------|--|-------|-------|-------|--------|
| | | | | | | | | | | | | | | | | | | | |
| 30 | LC | | | | | | | | | | | | | | | | 8,7* | 8,7* | 12' 5" |
| 25 | LC | | | | | | | | | | | | | | | | 6,6* | 6,6* | 19' 8" |
| 20 | LC | | | | | | | | | | | | | | | | 5,9* | 5,9* | 23'10" |
| 15 | LC | | | | | | | | | | | | | | | | 5,8* | 5,8* | 26' 4" |
| 10 | LC | 29,4* | 29,4* | 18,7* | 18,7* | 14,5 | 14,5* | 10,5 | 11,7* | | | | | | | | 5,9* | 5,9* | 27' 7" |
| 5 | LC | 28,6* | 28,6* | 20,9 | 21,5* | 14,3 | 15,7* | 10,4 | 12,6* | | | | | | | | 6,2* | 6,2* | 28' |
| 0 | LC | 31,6* | 31,6* | 20,9 | 22,4* | 14,3 | 16,2* | 10,2 | 12,7* | | | | | | | | 6,9* | 6,9* | 27' 5" |
| -5 | LC | 35,9* | 35,9* | 21,2 | 22,6* | 14,1 | 16,4* | 9,9 | 11,5* | | | | | | | | 8,1* | 8,1* | 25'10" |
| -10 | LC | 37,2* | 37,2* | 21,1 | 23,4* | 13,6 | 15,2* | | | | | | | | | | 9,9* | 9,9* | 22'11" |
| -15 | LC | 31,1* | 31,1* | 15,8* | | | | | | | | | | | | | 12,0* | 12,0* | 16' 6" |

Height Can be slewed through 360° In longitudinal position of undercarriage Max. reach * Limited by hydr. capacity

The lift capacities on the stick end without attachment are stated in lb x 1,000 and can be slewed through 360° on a firm, level supporting surface. Capacities are valid for 30" wide triple grouser pads. The values apply with the optimum positioning of the two-piece boom. Indicated loads based on the ISO 10567 standard and do not exceed 75% of tipping or 87% of hydraulic capacity. The lift capacity of the unit is limited by its stability, the lifting capability of the hydraulic elements, or the maximum permissible lifting capacity of the load hook.

Machine Stabilities Sorting Grabs

LH 26 M – Max. Material Weight in lb/yd³

| Grab | Shell type | Capacity yd ³ | Direct mounting with mounting plate | | Mounting with SWA 48 | |
|--------|------------|-----------------------------|-------------------------------------|-------|----------------------|-------|
| | | | GK11 | VK9 | GK11 | VK9 |
| SG 20B | perforated | 0.52 | 5,899 | 3,708 | 4,720 | 2,528 |
| SG 20B | perforated | 0.65 | 4,551 | 2,865 | 3,540 | 1,854 |
| SG 20B | perforated | 0.78 | 3,540 | 2,191 | 2,865 | 1,348 |
| SG 20B | perforated | 0.92 | 3,034 | 1,686 | 2,360 | 1,180 |
| SG 20B | closed | 0.52 | 5,731 | 3,708 | 4,551 | 2,528 |
| SG 20B | closed | 0.65 | 4,382 | 2,697 | 3,540 | 1,854 |
| SG 20B | closed | 0.78 | 3,540 | 2,191 | 2,865 | 1,348 |
| SG 20B | closed | 0.92 | 2,865 | 1,686 | 2,360 | 1,011 |
| SG 25B | perforated | 0.72 | 3,371 | 1,854 | 2,528 | 1,011 |
| SG 25B | perforated | 0.98 | 2,191 | 1,180 | 1,686 | 506 |
| SG 25B | perforated | 1.18 | 1,686 | 843 | 1,180 | 337 |
| SG 25B | perforated | 1.44 | 1,348 | 506 | 843 | – |
| SG 25B | ribbed | 0.65 | 3,540 | 1,854 | 2,528 | 843 |
| SG 25B | ribbed | 0.85 | 2,528 | 1,180 | 1,686 | 506 |
| SG 25B | ribbed | 1.18 | 1,854 | 674 | 1,180 | – |
| SG 25B | closed | 0.72 | 3,203 | 1,686 | 2,360 | 843 |
| SG 25B | closed | 0.98 | 2,191 | 1,011 | 1,517 | 506 |
| SG 25B | closed | 1.18 | 1,686 | 843 | 1,180 | – |
| SG 25B | closed | 1.44 | 1,348 | 506 | 843 | – |

– = Load values at maximum outreach insufficient

LH 26 C – Max. Material Weight in lb/yd³

| Grab | Shell type | Capacity yd ³ | Direct mounting with mounting plate | | Mounting with SWA 48 | |
|--------|------------|-----------------------------|-------------------------------------|-------|----------------------|-------|
| | | | GK11 | VK9 | GK11 | VK9 |
| SG 20B | perforated | 0.52 | 2,528 | 3,708 | 1,348 | 2,528 |
| SG 20B | perforated | 0.65 | 1,854 | 2,865 | 843 | 1,854 |
| SG 20B | perforated | 0.78 | 1,348 | 2,191 | 506 | 1,348 |
| SG 20B | perforated | 0.92 | 1,011 | 1,686 | 337 | 1,180 |
| SG 20B | closed | 0.52 | 2,360 | 3,708 | 1,180 | 2,528 |
| SG 20B | closed | 0.65 | 1,686 | 2,697 | 843 | 1,854 |
| SG 20B | closed | 0.78 | 1,348 | 2,191 | 506 | 1,348 |
| SG 20B | closed | 0.92 | 1,011 | 1,686 | 337 | 1,011 |
| SG 25B | perforated | 0.72 | 843 | 1,854 | – | 1,011 |
| SG 25B | perforated | 0.98 | 506 | 1,180 | – | 506 |
| SG 25B | perforated | 1.18 | 337 | 843 | – | 337 |
| SG 25B | perforated | 1.44 | – | 506 | – | – |
| SG 25B | ribbed | 0.65 | 843 | 1,854 | – | 843 |
| SG 25B | ribbed | 0.85 | 337 | 1,180 | – | 506 |
| SG 25B | ribbed | 1.18 | – | 674 | – | – |
| SG 25B | closed | 0.72 | 843 | 1,686 | – | 843 |
| SG 25B | closed | 0.98 | 337 | 1,011 | – | 506 |
| SG 25B | closed | 1.18 | – | 843 | – | – |
| SG 25B | closed | 1.44 | – | 506 | – | – |

– = Load values at maximum outreach insufficient

Attachments

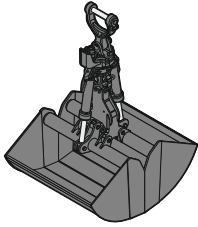

Grab for Loose Material

Shells for loose material with cutting edge (without teeth)

Grab model GM 10B

| | | | | | |
|-----------------|-----------------|-------|-------|-------|-------|
| Width of shells | ft in | 3'3" | 4'3" | 4'11" | 5'11" |
| Capacity | yd ³ | 1.31 | 1.70 | 1.96 | 2.35 |
| Weight | lb | 2,415 | 2,500 | 2,635 | 3,360 |

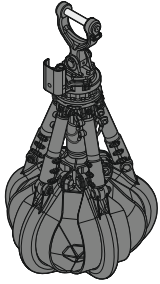

Multi-Tine Grab

open

semi-closed

closed

Grab model GM 64 (4 tines)

| | | | | | | | |
|----------|-----------------|-------|-------|-------|-------|-------|-------|
| Capacity | yd ³ | 0.52 | 0.78 | 0.52 | 0.78 | 0.52 | 0.78 |
| Weight | lb | 1,765 | 2,005 | 2,070 | 2,335 | 2,425 | 2,790 |

Grab model GM 65 (5 tines)

| | | | | | | | |
|----------|-----------------|-------|-------|-------|-------|-------|-------|
| Capacity | yd ³ | 0.52 | 0.78 | 0.52 | 0.78 | 0.52 | 0.78 |
| Weight | lb | 2,590 | 2,890 | 2,975 | 3,285 | 3,010 | 3,540 |

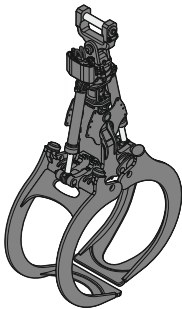

Wood Grab

Grab model GM 10B round-shaped (complete overlapping, vertical cylinders)

| | | | | |
|------------------------|-----------------|-------|-------|-------|
| Size | yd ² | 0.96 | 1.20 | 1.55 |
| Cutting width | ft in | 2'8" | 2'8" | 2'8" |
| Height of grab, closed | ft in | 7' | 7'5" | 7'10" |
| Weight | lb | 2,780 | 2,875 | 3,000 |

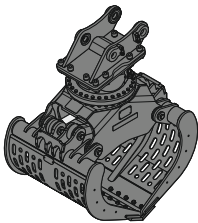

Sorting Grab

per-forated

ribbed

closed

per-forated

ribbed

closed

per-forated

ribbed

closed

per-forated

closed

Grab model SG 25B

| | | | | | | | | | | | | |
|--------------------------------|-----------------|--------|--------|--------|--------|--------|--------|--------|--------|--------|--------|--------|
| Width of shells | ft in | 2'7" | 2'7" | 2'7" | 3'3" | 3'3" | 3'3" | 3'11" | 3'11" | 3'11" | 4'7" | 4'7" |
| Capacity | yd ³ | 0.72 | 0.65 | 0.72 | 0.98 | 0.85 | 0.98 | 1.18 | 1.05 | 1.18 | 1.44 | 1.44 |
| Max. closing force | lbf | 13,489 | 13,489 | 13,489 | 13,489 | 13,489 | 13,489 | 13,489 | 13,489 | 13,489 | 13,489 | 13,489 |
| Weight incl. adapter plate SWA | lb | 2,735 | 2,835 | 2,780 | 2,875 | 3,020 | 2,930 | 3,020 | 3,210 | 3,085 | 3,165 | 3,240 |



Load Hook

| | | |
|------------------------|-------|--------|
| Max. load | lb | 27,560 |
| Height with suspension | ft in | 3'1" |
| Weight | lb | 300 |

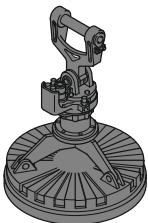



Magnet Devices / Lifting Magnets

| | | | |
|--------------------------------------|-------|--------|--------|
| Generator | kW | 10 | 10 |
| Electromagnet with suspension | | | |
| Power | kW | 5.5 | 8.8 |
| Diameter of magnet | ft in | 3'9" | 4'1" |
| Weight | lb | 2,480* | 3,120* |

* only magnet plate

Equipment

|  Undercarriage | 26 M | 26 C |
|--|------|------|
| Track pads, variants | | + |
| Individual control outriggers | + | |
| Shuttle axle lock, automatic | • | |
| Outrigger monitoring system | + | |
| Tires, variants | + | |
| Trailing cable | • | • |
| Protection for piston rods, outriggers | + | |
| Two lockable storage compartments | • | |
| Cable reel system | + | + |

|  Uppercarriage | 26 M | 26 C |
|--|------|------|
| Uppercarriage right side light, 1 piece, LED | • | • |
| Uppercarriage rear light, 2 pieces, LED | + | + |
| Generator | + | + |
| Main battery switch for electrical system | • | • |
| Recycling package | • | • |
| Amber beacon, at uppercarriage, LED double flash | + | + |
| Protection for headlights | + | + |
| Protection for rear lights | + | + |
| Tool equipment, extended | + | + |

|  Hydraulic System | 26 M | 26 C |
|---|------|------|
| Electronic pump regulation | • | • |
| Liebherr hydraulic oil from -4 °F to +104 °F | • | • |
| Liebherr hydraulic oil, biologically degradable | + | + |
| Magnetic rod in hydraulic tank | • | • |
| Bypass filter | + | + |
| Preheating hydraulic oil | + | + |

|  Engine | 26 M | 26 C |
|---|------|------|
| Automatic engine shut-down (time adjustable) | + | + |
| Preheating coolant * | + | + |

|  Cooling System | 26 M | 26 C |
|---|------|------|
| Radiator, large-mesh, for dust-intensive operation | • | • |
| Reversible fan drive, fully automatic | + | + |
| Protective grid (close-mesh) in front of cooler intake, extendible | • | • |

|  Operator's Cab | 26 M | 26 C |
|--|------|------|
| Stabilizer, control lever, left console | + | |
| Stabilizer, proportional control on left joystick | • | |
| Cab lights front, halogen | + | + |
| Cab lights front, halogen (under rain cover) | • | • |
| Cab lights front, LED | + | + |
| Cab lights front, LED (under rain cover) | + | + |
| Armrest adjustable | • | • |
| Slewing gear brake Comfort, button on the left or right joystick | + | + |
| Operator's seat Comfort | • | • |
| Operator's seat Premium | + | + |
| Driving alarm (acoustic signal is emitted during travel, can be switched ON/OFF) | + | + |
| Fire extinguisher | + | + |
| Footrest | + | + |
| Horn, button on left joystick | • | • |
| Joystick steering (max. 7.5 mph) | • | |
| Joystick and wheel steering (slim version) | + | |
| Cab elevation, hydraulic (LHC) | • | • |
| Cab elevation, rigid (LFC) | + | + |
| Wheel steering (slim version) | + | |
| LiDAT, vehicle fleet management | • | • |
| Engine shut-down (emergency stop) cab | • | • |
| Proportional control | • | • |
| Radio Comfort, control via display with handsfree set | + | + |
| Preparation for radio installation | • | • |
| Back-up alarm (acoustic signal is emitted traveling backward, can not be switched off) | + | |
| Amber beacon, on cabin, LED double flash | + | + |
| Windows made from impact-resistant laminated safety glass | + | + |
| Windscreen wiper, roof | + | + |
| Windshield wiper, entire windscreen | • | • |
| Top guard | + | + |
| Front guard, adjustable | + | + |
| Sun visor | + | + |
| Stationary air-conditioning | • | • |
| Left control console, folding | • | • |

|  Equipment | 26 M | 26 C |
|---|------|------|
| Boom lights, 2 pieces, halogen | • | • |
| Boom lights, 2 pieces, LED | + | + |
| Stick lights, 2 pieces, halogen | • | • |
| Stick lights, 2 pieces, LED | + | + |
| Filter system for attachment | + | + |
| Height limitation and stick shutoff, electronically | + | + |
| Boom cylinder cushioning | + | + |
| Stick camera (with separate monitor), bottom side, with protection | + | + |
| Liebherr multi coupling system | + | + |
| Liebherr quick coupler, hydraulic | + | + |
| Pipe fracture safety valves hoist cylinders | • | • |
| Pipe fracture safety valves stick cylinders | • | • |
| Quick coupling system LIKUFIX | + | + |
| Quick coupling system MH 40B | + | + |
| Protection for piston rods, hoist cylinder | + | + |
| Protection for piston rods, stick cylinder | + | + |
| Overload warning device | + | + |

|  Complete Machine | 26 M | 26 C |
|--|------|------|
| Lubrication | | |
| Lubrication undercarriage, manually – decentralized (grease points) | • | |
| Lubrication undercarriage, manually – centralized (one grease point) | + | |
| Central lubrication system for uppercarriage and equipment, automatically | • | • |
| Central lubrication system for undercarriage, automatically | + | |
| Central lubrication system, extension for attachment | + | + |
| Special coating | | |
| Special coating, variants | + | + |
| Monitoring | | |
| Rear view monitoring with camera | • | • |
| Side view monitoring with camera | • | • |

• = Standard, + = Option
 * = country-dependent

Options and/or special equipments, supplied by vendors other than Liebherr, are only to be installed with the knowledge and approval of Liebherr in order to retain warranty.

The Liebherr Group of Companies



Diverse Product Range

The Liebherr Group is one of the largest construction equipment manufacturers in the world. Liebherr's quality products and services hold a high reputation in many industries. The wide range includes domestic appliances, aerospace and transportation systems, machine tools and maritime cranes.

Exceptional Customer Benefit

Every product line provides a complete range of models in many different versions. With both their technical excellence and superior quality, Liebherr products offer customers the highest benefits in practical applications.

State-of-the-art Technology

Liebherr attributes great importance to the product areas of core technology and components, in order to achieve its consistent, top-quality products. Important modules and components are developed and manufactured in-house, for instance, the entire drive and control technology for the construction equipment and mining trucks.

Worldwide and Family-Owned

Hans Liebherr founded the Liebherr family company in 1949. Since that time, the enterprise has steadily grown to a group of more than 130 companies with more than 46,000 employees located on all continents. The corporate headquarters of the Group is Liebherr-International AG in Bulle, Switzerland. The Liebherr family is the sole owner of the company.

www.liebherr.us

Liebherr USA, Co.

Construction Equipment Division
4100 Chestnut Avenue, Newport News, VA 23607, USA
☎ +1 (757) 245 5251, Fax +1 (757) 928 8701
www.liebherr.us, E-Mail: Construction.USA@liebherr.com
www.facebook.com/LiebherrConstruction