

Material Handling Machines

# LH 30 Industry

Litronic®

# LH 35 Industry

Litronic®

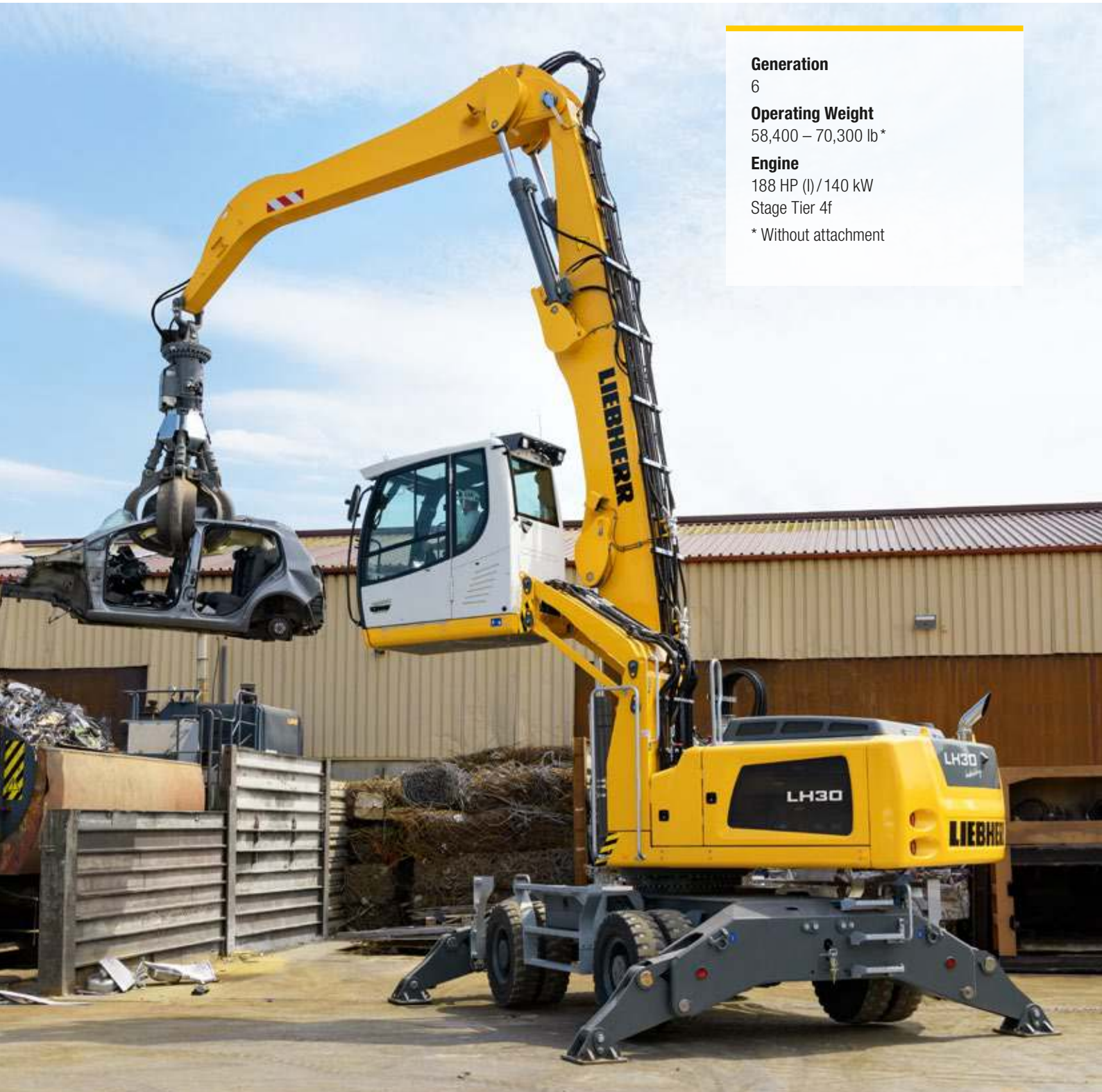

**Generation**

6

**Operating Weight**

58,400 – 70,300 lb\*

**Engine**

188 HP (l)/140 kW

Stage Tier 4f

\* Without attachment

# LIEBHERR



## Performance

Power Plus Speed –  
Redefined Performance

## Economy

Good Investment –  
Savings for Long-Term

### LH 30 M Industry Litronic

**Operating Weight**  
58,400 – 64,200 lb\*

#### Engine

188 HP (l)/140 kW  
Stage Tier 4f

### LH 35 M Industry Litronic

**Operating Weight**  
67,700 – 70,300 lb\*

#### Engine

188 HP (l)/140 kW  
Stage Tier 4f

### LH 30 C Industry Litronic

**Operating Weight**  
59,700 – 66,600 lb\*

#### Engine

188 HP (l)/140 kW  
Stage Tier 4f

\* Without attachment





## Reliability

Durability and Sustainability –  
Quality Down to the Last Detail

## Comfort

Perfection at a Glance –  
When Technology is Comfortable

## Maintainability

Efficiency Bonus –  
Even with Maintenance and Service





# Performance



## Power Plus Speed – Redefined Performance

Liebherr has been designing and manufacturing market leading material handling machines for over 50 years. The new generation of Liebherr handlers, the LH 30 and LH 35 are high performance yet economical machines specially designed for use in scrap recycling, in timber yards and also for bulk handling.



## Maximum Handling Capacity

### High Engine Performance

The optimized design of the 140 kW engine supplies a high torque output for fast and strong movements. Load peaks are cleverly compensated for to ensure that maximum torque is available at all times for highest handling capacity.

### High Swing Torque

The separate hydraulic pump in the closed slewing circuit only supplies hydraulic fluid to the swing mechanism. The maximum delivery volume is thus available at any time for turning the uppercarriage for fast and dynamic rotational movements.

### Captivating Dynamics

The combination of 140 kW of engine output and an increased pump delivery volume guarantees maximum acceleration and speed of working motions.

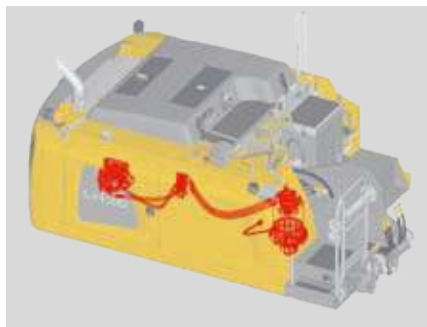

### Liebherr Diesel Engine Compliant with Tier 4f

- Powerful, robust and reliable
- Maximum torque even at low speeds to ensure fast movements with low fuel consumption
- Common-Rail injection system for maximum efficiency
- Emissions treatment with Liebherr SCR technology

### Closed Slewing Circuit

- High torque for maximum acceleration and fast rotary movements
- Integrated speed sensor for controlling and monitoring braking movement for greater safety
- Greater fuel efficiency thanks to intelligent energy management in the closed system

### Travel Motor

- Powerful, robust, reliable and quiet
- Better performance even on uphill grades due to electrical swivel angle adjustment for more torque, maximum acceleration and more driving power
- Fuel efficiency at maximum speed due to optimal adjustment of speed and delivery volume

## Precision Operation

### Intelligent Electronics

The elaborate machine controls guarantee that the hydraulics are optimally configured for the task at hand. Here, the load sensing control ensures that the flow delivered by the pump is optimally distributed when movements overlap. Speed and power are available whenever they are needed.

### Sensitive Hydraulics

The optimal harmonisation between the engine and the control valve allows a fast and direct response from the hydraulics to the input command. This is controlled proportionally to enable smooth and gentle movements to be executed when the joystick is moved.

### Firm and Stable Positioning

An essential prerequisite for precise working and maximum handling capacity is the firm and stable positioning of the machine. The design of the Liebherr undercarriage optimizes the way forces are induced on components to minimise stress and guarantee maximum stability and durability.



# Economy



## Good Investment – Savings for the Long-term

Liebherr material handling machines combine high productivity with excellent economy – all as standard. Liebherr manages to achieve this difficult goal through sophisticated engine technology from its own production and improved demand-controlled hydraulics.



# Fuel Efficiency

## Lower Engine RPM

A low engine speed of 1,700 rpm and high torque values allow the operating point of the machine to be quickly achieved. This gives excellent fuel efficiency and high handling performance.

## Engine Idling and Engine Shut-down

The standard automatic idling function reduces the engine speed to idle as soon as the operator takes their hand from the joystick so that no hydraulic function is activated. Proximity sensors in the joystick levers restore the original engine speed as soon as the operator's hand is moved towards the lever again. This ensures that the set engine speed is available immediately. The result is a combination of fuel saving and reduced noise levels. Operating costs can be reduced even further with the optional automatic engine shut-down function.

## Closed Hydraulic Circuit for the Swing Mechanism

The closed slewing circuit feeds the braking energy back into the system when the uppercarriage is braked. Here, new standards are set in terms of efficiency and economy. Simple yet effective.

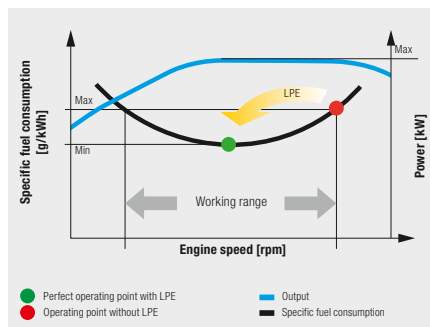

# Increased Productivity

## Attachments and Quick Coupling Systems

Liebherr offers a wide selection of attachments for every application to increase the productivity of its material handling machines. In addition the material handlers can be fitted with a Liebherr quick coupling system which increase the productivity of the machine by up to 30%. The matching attachment and quick coupling system combined with the outstanding dynamics of a Liebherr handler ensures highest handling capacity and maximum productivity.

## Efficient Management

LiDAT, Liebherr's own data transmission and positioning system, facilitates efficient management, monitoring and control of the entire fleet park in terms of machinery data recording, data analysis, fleet park management and service. All of the important machinery data can be viewed at any time in a web browser. LiDAT offers you comprehensive work deployment documentation, greater availability thanks to shorter downtimes, faster support from the manufacturer, quicker detection of strain/overload and subsequently a longer service life of the machine as well as greater planning efficiency in your company. This service includes 1 year of use without charge as standard for the material handlers LH 30 and LH 35.

## Low Fuel Consumption Thanks to Intelligent Machine Control

- Liebherr-Power Efficiency (LPE) optimizes the interaction of the drive components in terms of efficiency
- LPE enables machine operation in the area of the lowest specific fuel use for less consumption and greater efficiency with the same performance

## Liebherr-Attachments

- Robust and service-friendly slewing drive, can be turned 360°
- Optimum filling and clamping performance for effective material handling
- Finite element method (FEM) optimized for a perfect relationship between grapple weight, volume and a very long service life

## Eco-Mode

- Reducing the engine speed by pressing a button
- Lower fuel consumption with unchanged high performance
- Economical and environmentally friendly working guaranteed
- Ideal for light to medium operations



# Reliability



## Durability and Sustainability – Quality Down to the Last Detail

Every day Liebherr material handlers show their qualities in a range of industrial applications all over the world. Years of experience, continuous development and the latest technologies provide maximum safety in use. Their robust, compact design and the use of components produced in-house ensure that the LH 30 and LH 35 are designed for a long service life.



## More Safety

### Pipe Fracture Safety Valves

The standard pipe fracture safety valves on the stick and hoist cylinders prevents the equipments from dropping in an unregulated way and ensure maximum safety during every operation.

### Working Range Limiters

For operations in which the working range should be limited, the material handling machines can be specified with an optional working range limitation feature. Height, depth, width and proximity settings can be made to ensure that collisions and resulting component damage are avoided.

### Overload Warning Device and Load Torque Limitation

The audible and visual overload warning system continuously tells the operator about the current load situation of the machine. Furthermore, load torque limitation automatically regulates the speed of the working hydraulics to allow the maximum load bearing capacity to be approached safely. In the event of an overload, the functions which could cause the machine to topple are disabled. Only movements back to the safe working range are then possible.



## High Machine Availability

### Quality and Competence

Our experience, understanding of customer needs and the technical implementation of these findings guarantee the success of the product. For decades, Liebherr has been inspirational with its depth of production and system solutions. Key components such as the diesel engine, electronic components, slewing ring, swivelling drive and hydraulic cylinders are developed and produced by Liebherr itself. The great depth of in-house manufacturing guarantees maximum quality and ensures that components are optimally configured to each other.

### Robust Design

All steel components are designed and manufactured by Liebherr itself. High-strength steel plates configured for the toughest of requirements result in high torsional stiffness and optimum absorption of forces induced for a longer service life.

### Intelligent Self Diagnostics

The innovative control electronics permanently monitor the vital functions of the machine to guarantee a high level of machine availability. Components which are critical for safety have a secondary redundancy feature to guarantee maximum safety and reliability.



### QPDM – Quality and Process Data Management

- QPDM allows production data to be logged, documented and evaluated
- Test specifications and machine documented automatically logged
- Ability to handle large quantities of data while maintaining uniform high quality

### Dust-intensive Jobs

- Large-dimension radiator with large mesh for optimum cooling performance even in very dusty places
- A new, sealed engine compartment prevent dust penetration
- Reversible fan reduces the rate at which the engine and radiator become clogged and guarantee good machine availability
- Folding air conditioning condenser for quicker and easier cleaning

### Equipment

- Components enhanced using FEM for maximum service life even if subjected to heavy lateral stresses during demanding tasks
- Cables routed internally to protect them from damage
- High load capacities with long reaches
- Reaches up to 50 ft

# Comfort



## Perfection at a Glance – When Technology is Comfortable

The newly designed operator's work station sets new standards in comfort. The Liebherr deluxe cab is spacious, has an ergonomic design and is very quiet. This ensures that the operator remains intent and fully concentrated throughout the working day and enables him to deliver a constantly high performance.



## Deluxe Cab

### Ergonomic Design

The modern cab design provides excellent conditions for healthy, focussed and productive work in maximum comfort. The color touchscreen display, the controls and operator's comfort seat are all coordinated to form a perfect ergonomic unit. In addition the ergonomic joysticks allow the machine operation to be both pleasant and precise.

### Excellent All Around Vision

The large areas of glass, different versions of cab elevations and the rear and side area monitoring systems provide the operator with an excellent view of their working area and the zone around the machine. This perfect view enhances the operator's safety and ensures that they can handle the machine safely at all times.

### Low Noise Levels

The use of viscoelastic mounts, good insulation and low-noise diesel engines from Liebherr minimizes noise emissions and vibrations. The noise levels are just 71 dB(A) in the operator's cab and 103 dB(A) outside. This means that the material handlers LH 30 and LH 35 have low noise to preserve people and the environment.



## Comfortable Operation

### Proportional Control

Precision and fine control of the material handling machine are especially important in applications such as waste separation or scrap recycling. Thanks to the standard proportional control, even such demanding operations can be mastered in style.

### Joystick Steering and Stabilizing

The standard joystick steering gives the operator an additional comfort boost. The steering movement can be conveniently executed using the joystick, eliminating the need to reposition during the work cycle. Substituting the steering wheel in favor of joystick steering provides additional legroom and a clear view of the working area. A new standard feature is Joystick control of the outriggers for more convenience and increased productivity.

### Color Touchscreen Display and Operation Unit

The 7" color touchscreen display is intuitive in its operation and provides continuous information about all important operating data. The shortcut keys can be individually assigned and are selected quickly and easily with the menu strip.

### Safe Access

- Foldable arm console for a safe and comfortable access
- Wide, non-slip steps and ergonomically positioned handles for an easy and safe access
- All access systems are designed to national guidelines and statutory regulations

### Operator's Seat Comfort with Adjustable Armrests

- Greater seating comfort due to variable damper hardness, lockable horizontal suspension, pneumatic lumbar support, seat heating and passive seat air conditioning for concentrated working
- Individual adjustment options for armrests, seat cushion depth, seat angle and head restraint for comfortable working

### Joystick with Proportional Control

- Good functionality with streamlined, ergonomic design
- 4-way mini joystick can be used to control all operations e.g. steering, outriggers and attachments etc.
- Joysticks – each with two newly designed buttons and a rocker switch – increase the number of functions available.

# Maintainability



## Efficiency Bonus – Even with Maintenance and Service

The Liebherr LH 30 and LH 35 material handling machines are powerful, robust, precise and efficient. They also feature integral maintenance benefits as a result of their service-based design. All maintenance work for Liebherr material handlers can be carried out quickly, easily and safely. This minimizes the machine's maintenance costs and downtime.



# Efficient Maintenance Concept

## Service-based Machine Design

The service-based machine design guarantees short servicing times, thus minimising maintenance costs due to the time it saves. All the maintenance points are easily accessible from the ground and easy to reach due to the large, wide-opening service doors. The enhanced service concept places the maintenance points close to each other and reduces their number to a minimum. This means that service work can be completed even more quickly and efficiently.

## Integral Maintenance Benefits

Maintenance work helps to keep the machine fully functional. However this kind of work leads to machine downtimes which have to be minimized. With change intervals of up to 2,000 hours for engine oil and up to 8,000 hours for hydraulic oil, Liebherr has significantly reduced the amount of maintenance and increased the productivity of the material handlers. In addition, central lubrication systems minimize daily maintenance.

# Your Competent Service Partner

## Remanufacturing

The Liebherr remanufacturing program offers cost-effective reconditioning of components to the highest quality standards. Various reconditioning levels are available: Replacement components, general overhaul or repair. The customer receives components with original part quality at a reduced cost.

## Competent Advice and Service

Competent advice is given at Liebherr. Experienced specialists provide decision guidance for your specific requirements: application-oriented sales support, service agreements, economical repair alternatives, original parts management, as well as remote data transmission for machine planning and fleet management.



### Lubrication as it Works

- Fully automatic central lubrication system for uppercarriage and equipment
- Can be extended as an option to the connection link, quick coupler and attachment
- Fully automatic central lubrication system for the undercarriage available as an option
- Lubricates without interrupting work to ensure better productivity and a long component service life

### Excellent Service Access

- Large, wide-opening service doors
- Engine oil, fuel, air and cab air filters are easily and safely accessible from the ground
- The oil level in the hydraulic tank can be checked from the cab
- Short service times for more productivity

### Rapid Spare Parts Service

- 24-hour delivery: Spare parts service is available for our dealers around the clock
- Electronic spare parts catalogue: Fast and reliable selection and ordering via the Liebherr online portal
- With online tracking, the current processing status of your order can be viewed at any time

# Material Handling Machines Overview

## Uppercarriage

- Greater fuel efficiency thanks to the latest engine technology with intelligent machine control
- 140 kW engine output and a high pump flow for fast work cycles, convincing dynamics and maximum handling performance
- Reversible fan and large-meshed cooler as a reliable, sealed unit for high machine availability
- Reduction in operating costs thanks to built-in maintenance advantages and optimum service accessibility

## Undercarriage

- Optimized hydraulics with closed slewing mechanism circuit for greater fuel efficiency and faster work cycles
- Maximum acceleration and higher drawbar pull thanks to a new travel motor for greater travelling performance
- Load-holding valves fitted as standard on all support cylinders for maximum stability in every application
- Less downtime thanks to maintenance-free support cylinders







### **Operator's Cab**

- Joystick steering without steering column as standard for convenient operation, greater legroom and clear view of the working area
- Less strain on the operator, workers and reduced environmental pollution due to lower noise emissions
- Optimum visibility thanks to large glass surfaces and standard rear and side area monitoring with camera
- Proportional control is standard with 4-way mini joystick for greater precision, high precision control and functions

### **Equipment**

- High load capacities and long reaches thanks to optimized kinematic properties and robust construction for greater handling performance
- Ingenious routing of hydraulic hoses optimizes the oil flow and minimises power losses for maximum energy efficiency
- Pipe fracture safety valves on hoist and stick cylinders and retract stick shut-off for maximum safety during every application
- Quick coupling systems and attachments made by Liebherr for maximum machine capacity utilization and greater handling performance

# The Perfect Solution for Every Application

## Attachments

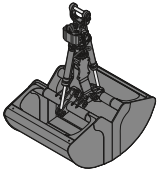

Shells for loose material

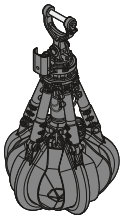

Multi-tine grab



Wood grab

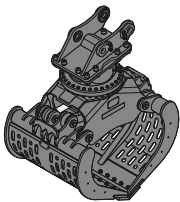

Sorting grab

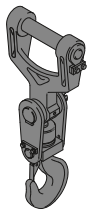

Load hook

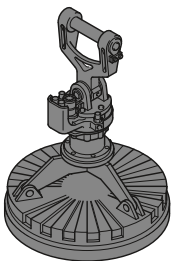

Magnet devices

## Sticks

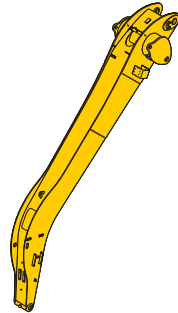

Angled stick

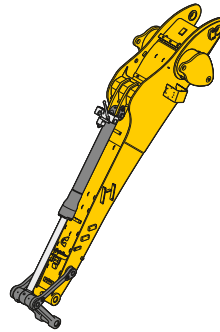

Stick with tipping kinematics

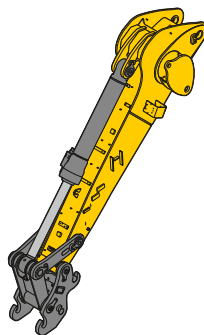

Stick for scrap shear

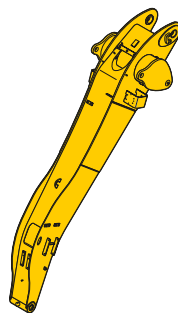

Flat angled stick

## Booms

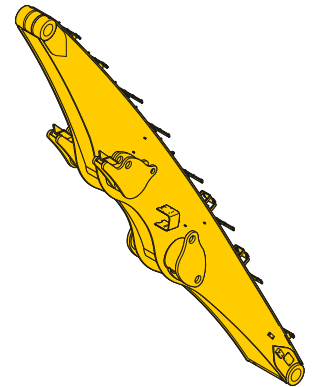

Straight boom

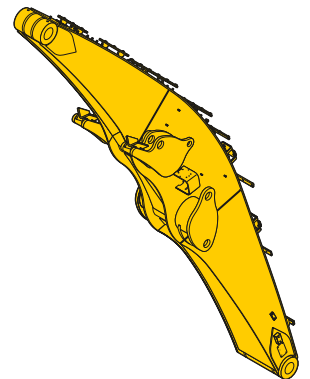

Angled boom



## Cab Elevations

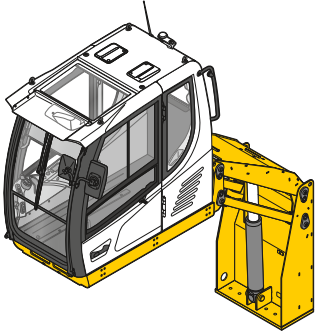

Hydraulic cab elevation

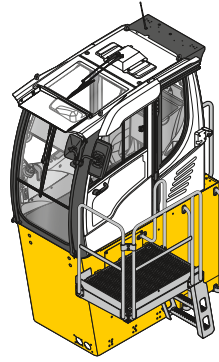

Rigid cab elevation

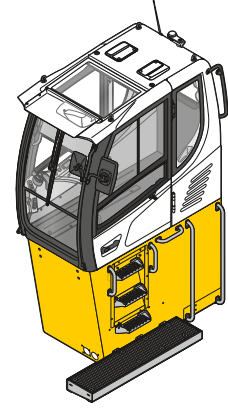

## Uppercarriage

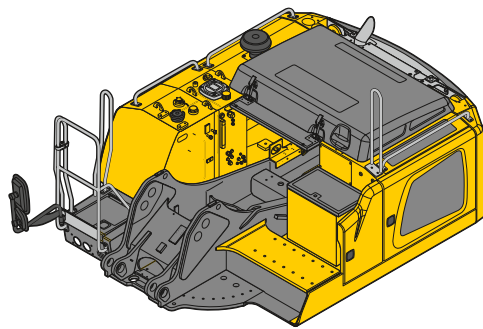

## Undercarriage

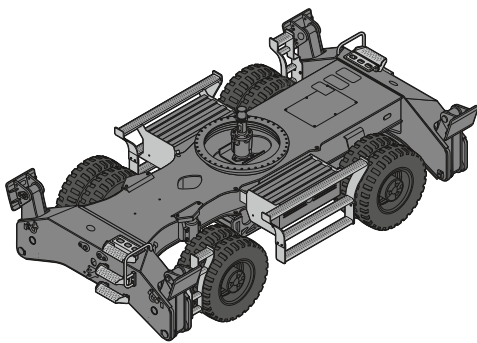

Mobile

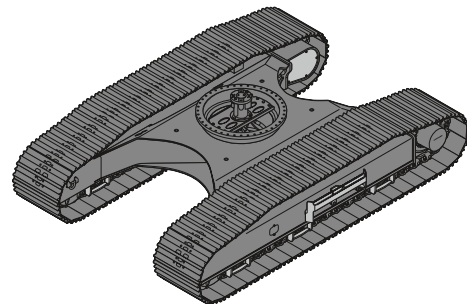

Crawler

# Experience the Progress

The invention of the mobile tower crane in 1949 also marked the birth of the Liebherr company. During its first decade the small construction company developed into an established manufacturer of construction machines and other technically advanced products. The R 353 and its first industrial equipment were launched in 1951 to lay the foundations for the production of today's material handling machines. The A 911

mobile material handling machine a few years later enabled the company to make the breakthrough into material handling. Over the years the machines have been developed continually and today they are designed uncompromisingly for industrial use.

**1949**

First tower crane TK10



**1968**

Breakthrough with the A 911 mobile material handler



**1974**

Silenced material handling machine



R 353 with the first industrial equipment

**1961**



Production plant in Kirchdorf

**1970**



First hydraulic cab elevation

**1983**



Liebherr has now been developing and manufacturing material handling machines for a very wide range of applications in the scrap, port and timber handling sectors and for the waste and recycling industry for over 50 years. In the development of its machines, Liebherr chooses quality, durability and reliability from the very outset, together with performance and economy. Years of experience in design and construction are not only

reflected in the end product but also in the components which are developed, designed and manufactured by Liebherr itself. This multiple sector expertise is used in product design from the early phase of the development process and thus allows high level technical innovations to be made.

**2007**

Opening of the assembly building for material handling machines



**2013**

Launch of the new LH series



**2016**

Launch of the new Port Material Handling Machines



Awarded the Bauma Design Prize for the LH 120

**2010**



Awarded the Bauma Innovation Prize for the ERC cylinder



Awarded the IF Award for the material handling machine LH 60

**2014**

# Technical Data



## Diesel Engine

<b>Rating per SAE J1349/ISO 9249</b>	188 HP (l) (140 kW) at 1,700 rpm
<b>Model</b>	Liebherr D934
<b>Type</b>	4 cylinder in-line
<b>Bore/Stroke</b>	4.8/5.9 in
<b>Displacement</b>	427,17 in <sup>3</sup>
<b>Engine operation</b>	4-stroke diesel Common-Rail turbo-charged and after-cooled reduced emissions
<b>Air cleaner</b>	dry-type air cleaner with pre-cleaner, primary and safety elements
<b>Engine idling</b>	sensor controlled
<b>Electrical system</b>	
Voltage	24 V
Batteries	2 x 135 Ah/ 12 V
Alternator	three-phase current 28 V/ 140 A
<b>Stage Tier 4f</b>	
Harmful emissions values	in accordance with EPA/CARB-40CFR stage Tier 4f
Emission control	Liebherr-SCR technology
Fuel tank	87 gal
Urea tank	12 gal



## Cooling System

<b>Diesel engine</b>	water-cooled compact cooling system consisting cooling unit for water, hydraulic oil and charge air with step-less thermostatically controlled fan
----------------------	---



## Hydraulic Controls

<b>Power distribution</b>	via control valves with integrated safety valves, simultaneous actuation of chassis and equipment. Swing drive in separate closed circuit
<b>Servo circuit</b>	
Equipment and swing	with hydraulic pilot control and proportional joystick levers
Chassis	
Mobile	electroproportional via foot pedal
Crawler	with hydraulic proportionally functioning foot pedals or adjusted with plugable levers
<b>Additional functions</b>	via switch or electroproportional foot pedals
Proportional control	proportionally acting transmitters on the joysticks for additional hydraulic functions



## Hydraulic System

<b>Hydraulic pump</b>	for equipment and travel drive	2 Liebherr axial piston variable displacement pumps (double construction)
Max. flow		2 x 61 gpm
Max. pressure		5,076 psi
for swing drive		reversible axial piston variable displacement pump, closed-loop circuit
Max. flow		37 gpm
Max. pressure		6,092 psi
<b>Hydraulic pump regulation and control</b>		Liebherr-Synchron-Comfort-system (LSC) with electronic engine speed sensing regulation, pressure and flow compensation
<b>Hydraulic tank</b>		46 gal
<b>Hydraulic system</b>		114 gal
<b>Hydraulic oil filter</b>		1 main return filter with integrated partial micro filtration (5 µm)
<b>MODE selection</b>		adjustment of engine and hydraulic performance via a mode pre-selector to match application, e.g. for especially economical and environmentally friendly operation or for maximum material handling and heavy-duty jobs
S (Sensitive)		mode for precision work and lifting through very sensitive movements
E (Eco)		mode for especially economical and environmentally friendly operation
P (Power)		mode for high performance with low fuel consumption
P+ (Power-Plus)		mode for highest performance and for very heavy duty applications, suitable for continuous operation
<b>Engine speed and performance setting</b>		stepless alignment of engine output and hydraulic power via engine speed
Option		Tool Control: 20 preadjustable pump flows and pressures for add-on attachments



## Swing Drive

<b>Drive</b>	Liebherr axial piston motor in a closed system, Liebherr planetary reduction gear
<b>Swing ring</b>	Liebherr, sealed race ball bearing swing ring, internal teeth
<b>Swing speed</b>	0 – 9,5 rpm stepless
<b>Swing torque</b>	56,055 lbf ft
<b>Holding brake</b>	wet multi-disc (spring applied, pressure released)
<b>Operation holding brake (Option)</b>	slewing gear brake Comfort





## Operator's Cab

<b>Cab</b>	TOPS safety cab structure (tip-over protection) with individual windscreens or featuring a slide-in subpart under the ceiling, work headlights integrated in the ceiling, a door with a sliding window (can be opened on both sides), large stowing and depositing possibilities, shock-absorbing suspension, sounddamping insulating, tinted laminated safety glass, separate shades for the sunroof window and windscreen
<b>Operator's seat Comfort</b>	air cushioned operator's seat with 3D-adjustable armrests, headrest, lap belt, seat heater, adjustable seat cushion inclination and length, lockable horizontal suspension, automatic weight adjustment, adjustable suspension stiffness, pneumatic lumbar vertebrae support and passive seat climatisation with active coal
<b>Operator's seat Premium (Option)</b>	in addition to operator's seat comfort: active electronic weight adjustment (automatic re-adjustment), pneumatic low frequency suspension and active seat climatisation with active coal and ventilator
<b>Control system</b>	joysticks with control consoles and swivel seat, folding left control console
<b>Operation and displays</b>	large high-resolution operating unit, self-explanatory, color display with touchscreen, video-compatible, numerous settings, control and monitoring options, e.g. air conditioning control, fuel consumption, machine and attachment parameters
<b>Air-conditioning</b>	automatic air-conditioning, recirculated air function, fast de-icing and demisting at the press of a button, air vents can be operated via a menu; recirculated air and fresh air filters can be easily replaced and are accessible from the outside; heating-cooling unit, designed for extreme outside temperatures, sensors for solar radiation, inside and outside temperatures



## Equipment

<b>Type</b>	high-strength steel plates at highly stressed points for the toughest requirements. Complex and stable mountings of equipment and cylinders
<b>Hydraulic cylinders</b>	Liebherr cylinders with special sealing and guide system and, depending on cylinder type, shock absorption
<b>Bearings</b>	sealed, low maintenance



## Undercarriage

<b>Mobile</b>	
Drive	oversized two speed power shift transmission with additional creeper speed, Liebherr axial piston motor with functional brake valve on both sides
Travel speed	
Joystick steering	0 – 2.2 mph stepless (creeper speed + transmission stage 1) 0 – 4.3 mph stepless (transmission stage 1) 0 – 7.5 mph stepless (creeper speed + transmission stage 2) 0 – 7.5 mph stepless (transmission stage 2)
Wheel steering (Option)	0 – 2.2 mph stepless (creeper speed + transmission stage 1) 0 – 4.3 mph stepless (transmission stage 1) 0 – 8.1 mph stepless (creeper speed + transmission stage 2) 0 – 12.4 mph stepless (transmission stage 2)
Driving operation	automotive driving using accelerator pedal, cruise control function: storage of variable accelerator pedal positions
Axles	88,185 lb / 132,277 lb drive axles (LH 30 M / LH 35 M); manual or automatic hydraulically controlled front axle oscillation lock
Option	four wheel steering (LH 35 M)
Service brake	two circuit travel brake system with accumulator; wet and backlash-free disc brake
Holding brake	wet multi-disc (spring applied, pressure released)
Stabilization	4 point outriggers
Option	dozer blade, at the front, for 4 point outriggers
<b>Crawler</b>	
Versions	LC, EW
Drive	Liebherr compact planetary reduction gear with Liebherr axial piston motor per side of undercarriage
Travel speed	0 – 1.9 mph stepless (creeper speed) LC-Undercarriage 0 – 1.9 mph stepless (creeper speed) EW-Undercarriage 0 – 2.9 mph stepless LC-Undercarriage 0 – 2.5 mph stepless EW-Undercarriage
Brake	functional brake valves on both sides
Holding brake	wet multi-disc (spring applied, pressure released)
Track pads	triple grouser
LC (Option)	rubber



## Complete Machine

<b>Lubrication</b>	Liebherr central lubrication system for upper-carriage and equipment, automatically	
Mobile (Option)	Liebherr central lubrication system for undercarriage, automatically	
<b>Steps system</b>	safe and durable access system with anti-slip steps; main components hot-galvanized	
<b>Noise emission</b>		
ISO 6396	L <sub>pA</sub> (inside cab)	= 71 dB(A)
2000/14/EC	L <sub>WA</sub> (surround noise)	= 103 dB(A)

# LH 30 M – Dimensions

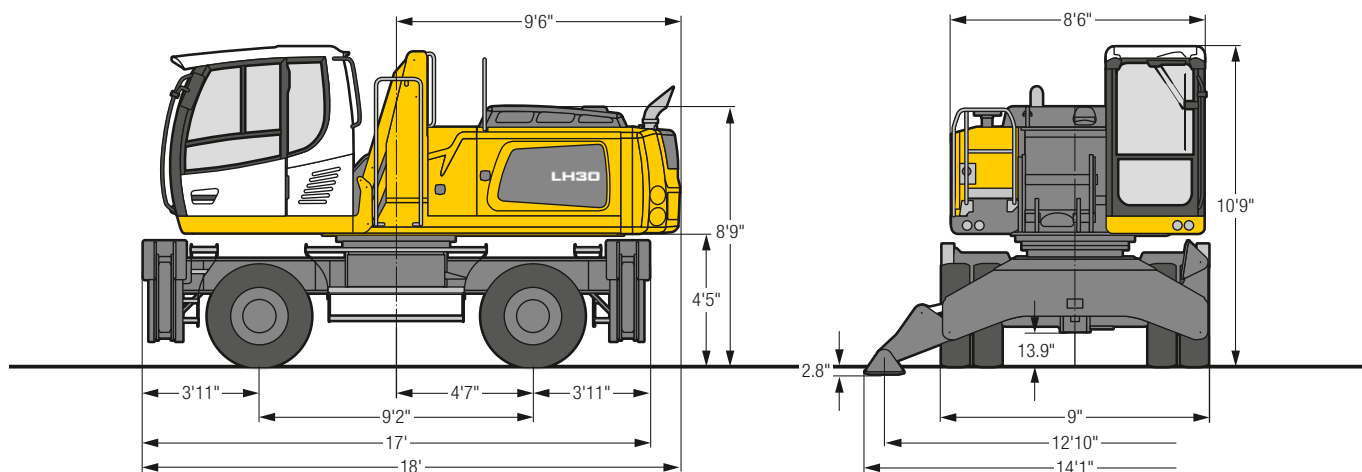

## LH 30 M – Choice of Cab Elevation

### Cab Elevation LFC (Rigid Elevation)

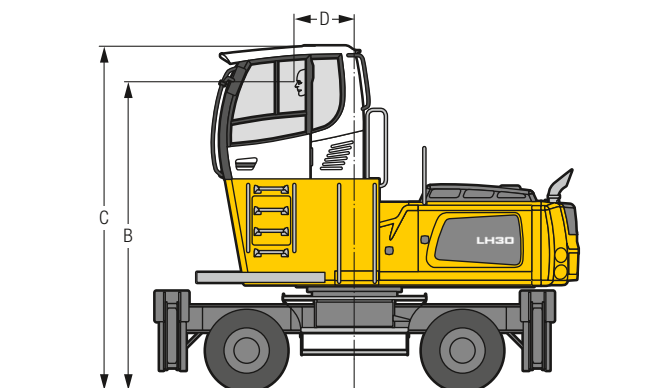

Increase type	LFC 120
Height	3' 11"
B	13' 2"
C	14' 8"
D	2' 7"

A rigid cab elevation has a fixed eye level height. For a lower transport height, the shell of the cab can be removed and replaced by a transport device. The dimension C is in this machine design for all rigid cab elevations 11'9".

### Cab Elevation LHC (Hydraulic Elevation)

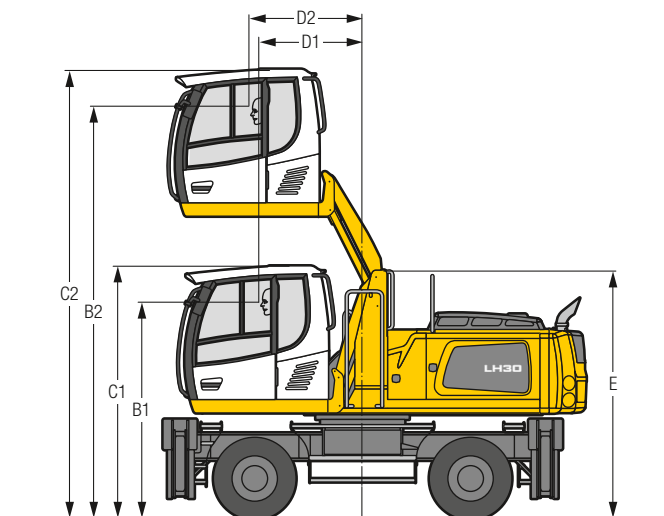

Increase type	LHC 255
B1	9' 3"
B2	17' 7"
C1	10' 9"
C2	19' 1"
D1	4' 5"
D2	4' 10"
E	10' 7"

The hydraulically adjustable cab allows the driver, that he can choose his field of view freely and at any time within the stroke.

Tires 10.00-20



# LH 35 M – Dimensions

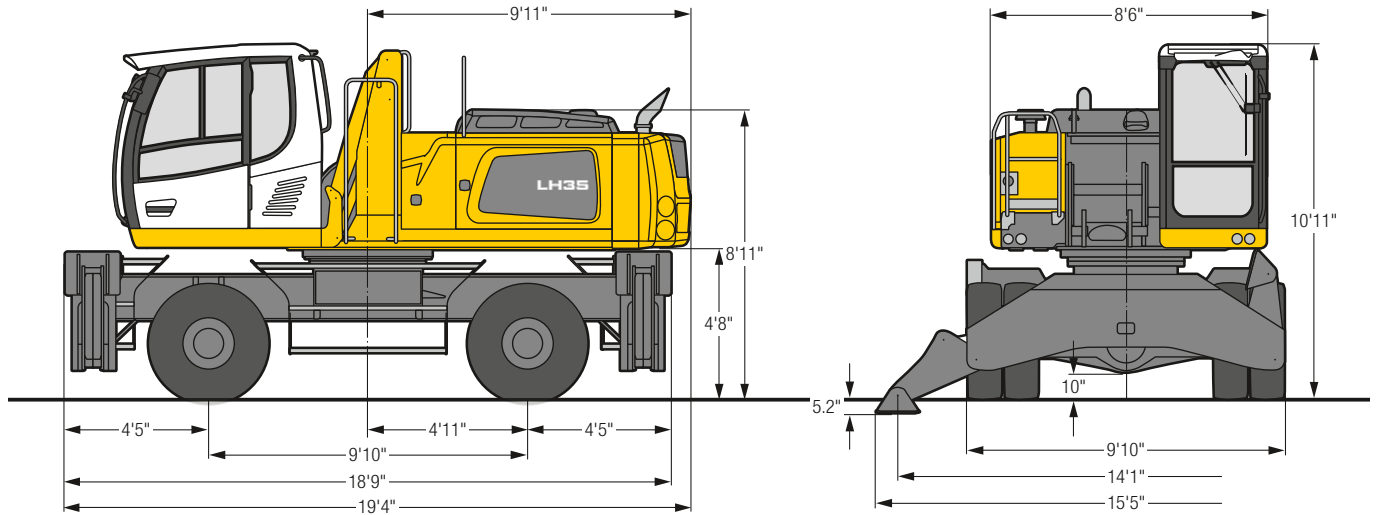

# LH 35 M – Choice of Cab Elevation

## Cab Elevation LFC (Rigid Elevation)

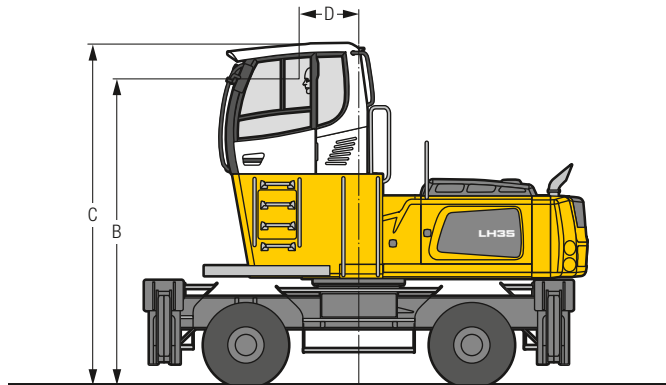

Increase type	LFC 120
Height	3' 11"
<b>B</b>	13' 4"
<b>C</b>	14' 11"
<b>D</b>	2' 7"

A rigid cab elevation has a fixed eye level height. For a lower transport height, the shell of the cab can be removed and replaced by a transport device. The dimension C is in this machine design for all rigid cab elevations 11'11".

## Cab Elevation LHC (Hydraulic Elevation)

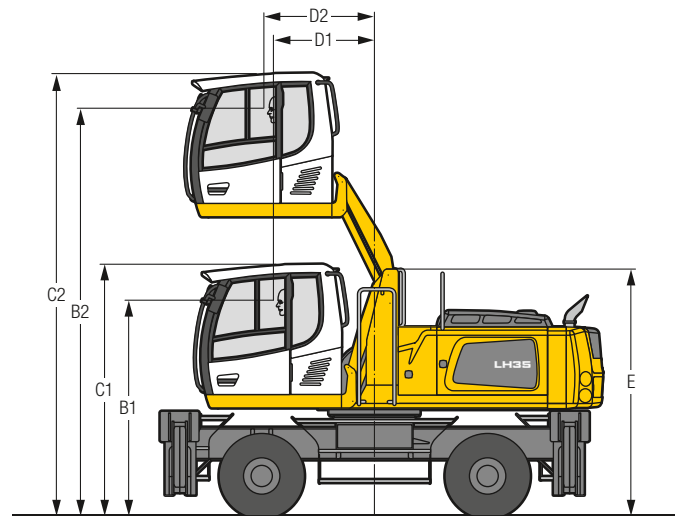

Increase type	LHC 255
<b>B1</b>	9' 5"
<b>B2</b>	17' 9"
<b>C1</b>	10' 11"
<b>C2</b>	19' 4"
<b>D1</b>	4' 5"
<b>D2</b>	4' 10"
<b>E</b>	10' 9"

The hydraulically adjustable cab allows the driver, that he can choose his field of view freely and at any time within the stroke.

Tires 12.00-20

# LH 30 C LC – Dimensions

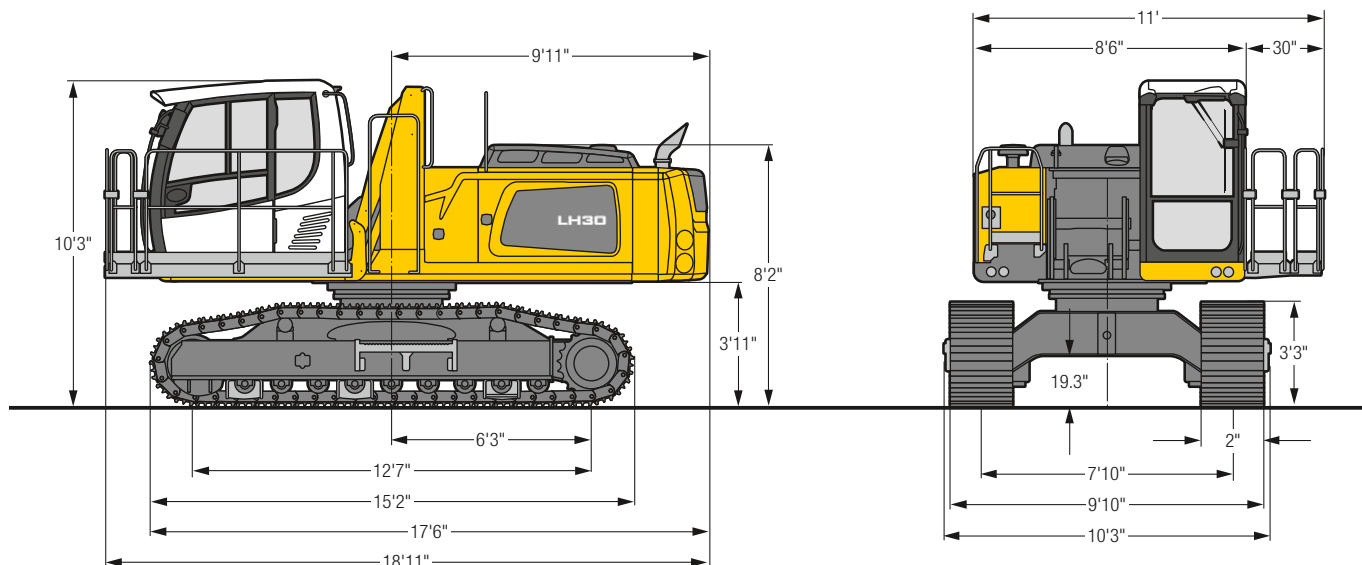

# LH 30 C LC – Choice of Cab Elevation

## Cab Elevation LFC (Rigid Elevation)

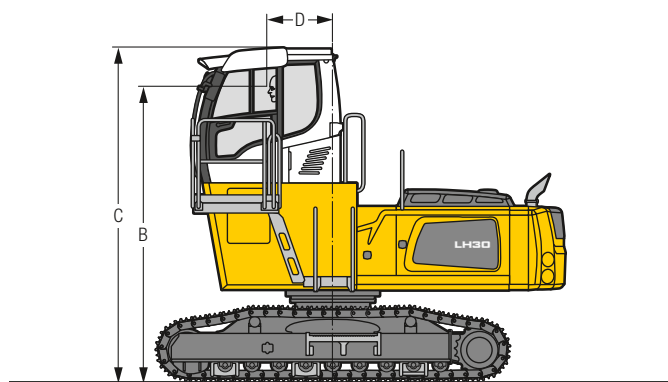

Increase type	LFC 120
Height	3'11"
B	12' 8"
C	14' 2"
D	2' 7"

A rigid cab elevation has a fixed eye level height. For a lower transport height, the shell of the cab can be removed and replaced by a transport device. The dimension C is in this machine design for all rigid cab elevations 11'3".

## Cab Elevation LHC (Hydraulic Elevation)

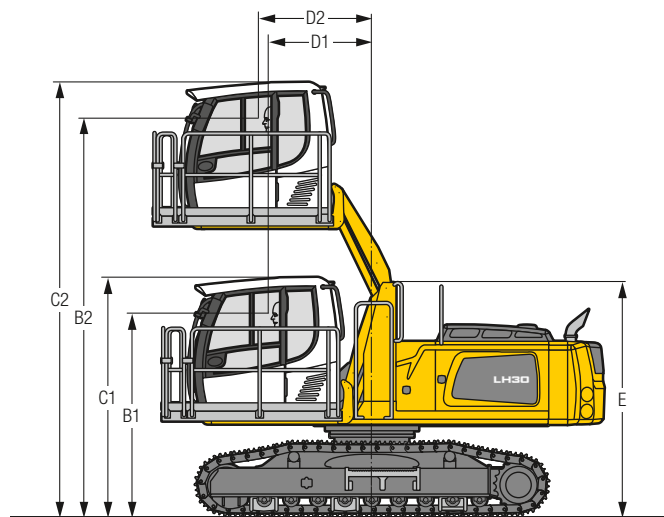

Increase type	LHC 255
B1	8' 8"
B2	17' 1"
C1	10' 3"
C2	18' 7"
D1	4' 5"
D2	4'10"
E	10'

The hydraulically adjustable cab allows the driver, that he can choose his field of view freely and at any time within the stroke.



# LH 30 C EW – Dimensions

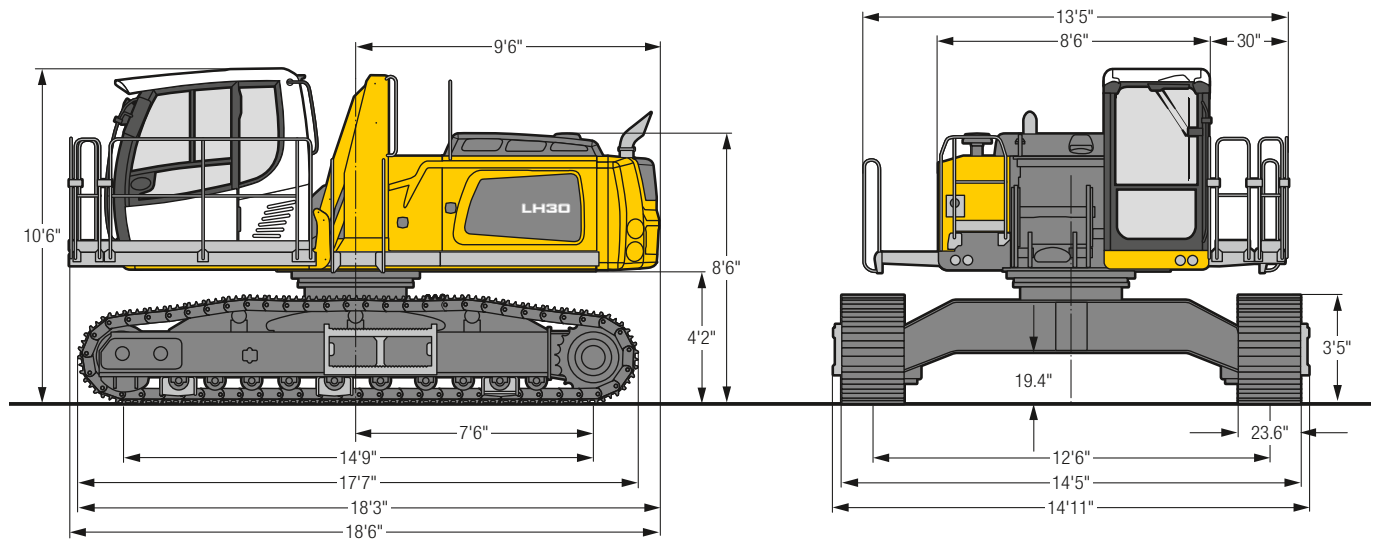

# LH 30 C EW – Choice of Cab Elevation

## Cab Elevation LFC (Rigid Elevation)

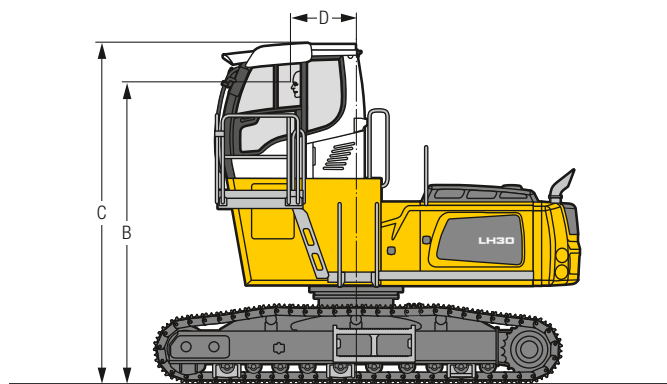

Increase type	LFC 120
Height	3'11"
B	12'11"
C	14' 5"
D	2' 7"

A rigid cab elevation has a fixed eye level height. For a lower transport height, the shell of the cab can be removed and replaced by a transport device. The dimension C is in this machine design for all rigid cab elevations 11'6".

## Cab Elevation LHC (Hydraulic Elevation)

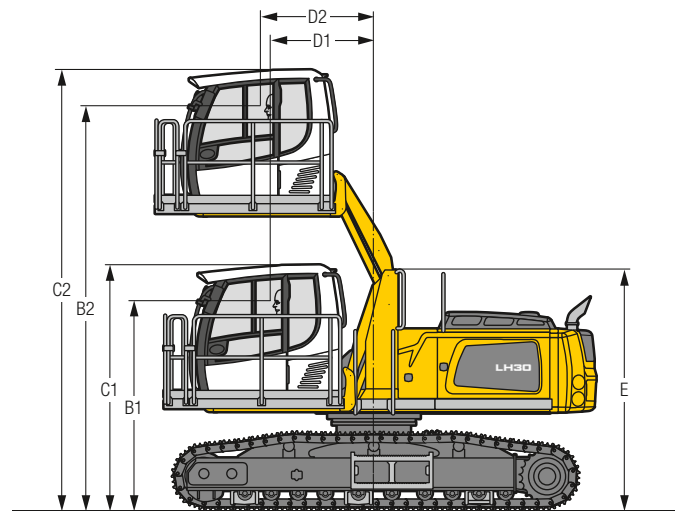

Increase type	LHC 255
B1	9'
B2	17' 4"
C1	10' 6"
C2	18'10"
D1	4' 5"
D2	4'10"
E	10' 4"

The hydraulically adjustable cab allows the driver, that he can choose his field of view freely and at any time within the stroke.

# LH 30 M – Equipment AF11

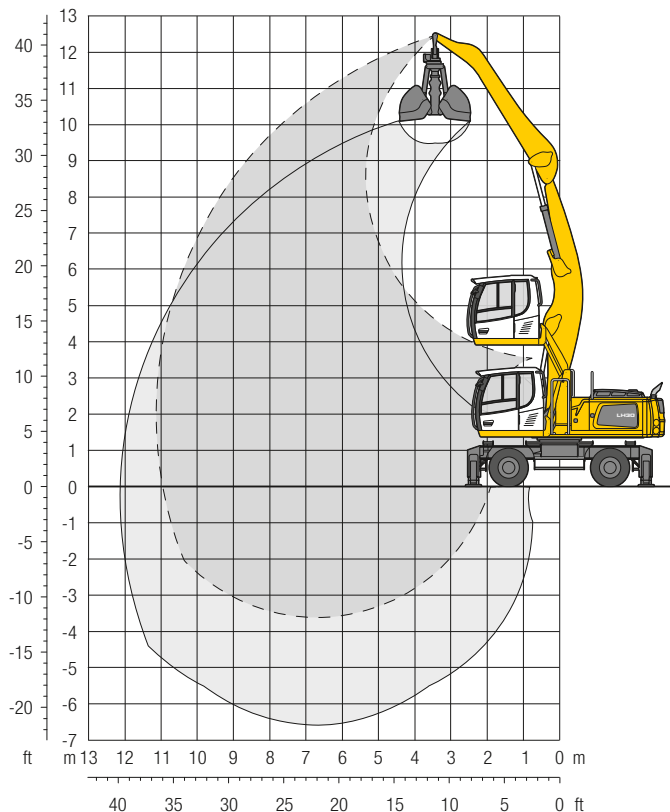

## Operating Weight

The operating weight includes the basic machine with 4 point outriggers, hydr. cab elevation, 8 solid tires plus intermediate rings, angled boom 21'4", flat angled stick 16'5" and grab for loose material GM 20C/1.96 yd<sup>3</sup>

Weight 63,300 lb

## Dimensions

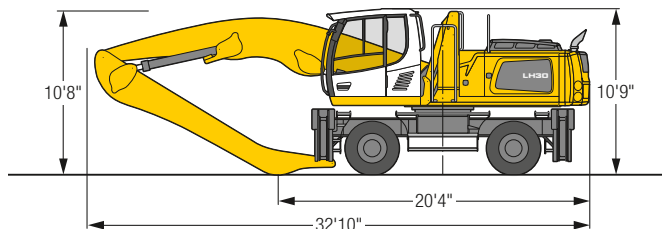

ft	Undercarriage	10 ft		15 ft		20 ft		25 ft		30 ft		35 ft		40 ft		45 ft		ft in			
		Stabilizers raised	4 pt. outriggers down	Stabilizers raised	4 pt. outriggers down	Stabilizers raised	4 pt. outriggers down	Stabilizers raised	4 pt. outriggers down	Stabilizers raised	4 pt. outriggers down	Stabilizers raised	4 pt. outriggers down	Stabilizers raised	4 pt. outriggers down	Stabilizers raised	4 pt. outriggers down	Stabilizers raised	4 pt. outriggers down	ft	in
40	Stabilizers raised																		14,2"	14,2"	13'10"
40	4 pt. outriggers down																		14,2"	14,2"	
35	Stabilizers raised					13,0	14,2*												10,4	11,0*	22' 8"
35	4 pt. outriggers down					14,2*	14,2*												11,0*	11,0*	
30	Stabilizers raised					13,3	15,9*	9,1	12,0										7,4	9,8	27'11"
30	4 pt. outriggers down					15,9*	15,9*	13,9*	13,9*										9,9*	9,9*	
25	Stabilizers raised					13,3	15,9*	9,2	12,0	6,6	8,8								6,0	8,0	31' 6"
25	4 pt. outriggers down					15,9*	15,9*	14,2*	14,2*	12,1*	12,1*								9,4*	9,4*	
20	Stabilizers raised					12,9	16,6*	9,0	11,8	6,5	8,7								5,1	7,0	34'
20	4 pt. outriggers down					16,6*	16,6*	14,6*	14,6*	12,9	13,0*								9,3*	9,3*	
15	Stabilizers raised			19,0	22,2*	12,2	16,1	8,6	11,4	6,3	8,5	4,8	6,5						4,6	6,3	35' 7"
15	4 pt. outriggers down			22,2*	22,2*	18,0*	18,0*	15,2*	15,2*	12,7	13,2*	9,8	10,8*						9,4*	9,4*	
10	Stabilizers raised	31,4	38,9*	17,0	23,5	11,2	15,1	8,0	10,8	6,0	8,2	4,6	6,4						4,3	6,0	36' 5"
10	4 pt. outriggers down	38,9*	38,9*	25,7*	25,7*	19,6*	19,6*	15,9*	15,9*	12,3	13,5*	9,7	11,4*						9,1	9,6*	
5	Stabilizers raised	13,0*	13,0*	15,0	21,2	10,2	14,1	7,5	10,2	5,7	7,8	4,5	6,2						4,2	5,8	36' 6"
5	4 pt. outriggers down	13,0*	13,0*	28,2*	28,2*	20,7*	20,7*	15,7	16,4*	12,0	13,5*	9,5	11,1*						8,9	10,2*	
0	Stabilizers raised	10,7*	10,7*	13,7	19,7	9,4	13,2	7,0	9,7	5,4	7,6	4,3	6,1						4,2	5,9	35'11"
0	4 pt. outriggers down	10,7*	10,7*	28,3*	28,3*	20,8*	20,8*	15,2	16,3*	11,7	13,1*	9,4	10,3*						9,0	9,6*	
-5	Stabilizers raised	12,6*	12,6*	13,0	19,0	8,9	12,7	6,7	9,4	5,3	7,4								4,4	6,1	34' 7"
-5	4 pt. outriggers down	12,6*	12,6*	25,5*	25,5*	19,5*	19,5*	14,8	15,3*	11,5	12,0*								8,9*	8,9*	
-10	Stabilizers raised			12,9	18,9	8,8	12,5	6,6	9,3										5,3	7,5	29' 7"
-10	4 pt. outriggers down			21,2*	21,2*	16,7*	16,7*	13,0*	13,0*										9,9*	9,9*	

Height Can be slewed through 360° In longitudinal position of undercarriage Max. reach \* Limited by hydr. capacity

The lift capacities on the stick end without attachment are stated in lb x 1,000 and are valid on a firm, level supporting surface with blocked oscillating axle. These capacities can be slewed through 360° with the undercarriage in the transverse position. Capacities in the longitudinal position of the undercarriage (+/- 15°) are specified over the steering axle with the stabilizers raised and over the rigid axle with the stabilizers down. Indicated loads based on the ISO 10567 standard and do not exceed 75% of tipping or 87% of hydraulic capacity. The lift capacity of the unit is limited by its stability, the lifting capability of the hydraulic elements, or the maximum permissible lifting capacity of the load hook.



# LH 30 M – Equipment GA12

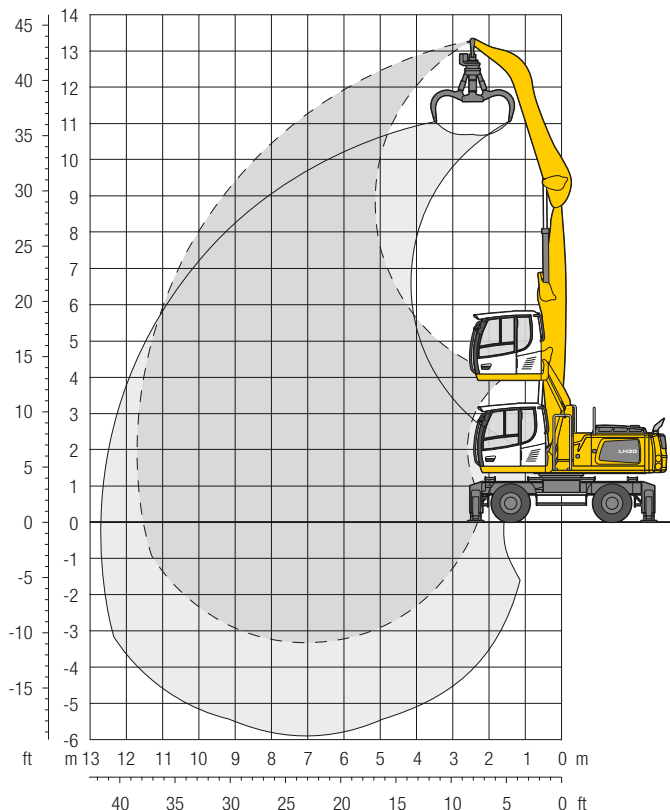

## Operating Weight

The operating weight includes the basic machine with 4 point outriggers, hydr. cab elevation, 8 solid tires plus intermediate rings, straight boom 22'4", angled stick 16'5" and multi-tine grab GM 65/0.78 yd<sup>3</sup> semi-closed tines.

Weight 62,600 lb

## Dimensions

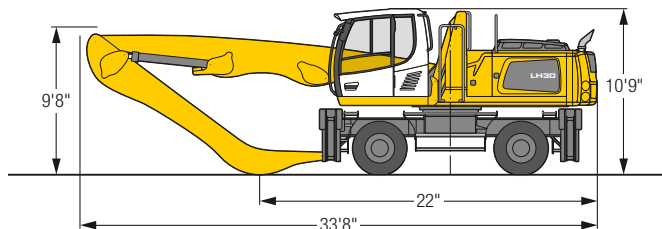

ft	Undercarriage	10 ft		15 ft		20 ft		25 ft		30 ft		35 ft		40 ft		45 ft		ft in			
		Stabilizers raised	4 pt. outriggers down	Stabilizers raised	4 pt. outriggers down	Stabilizers raised	4 pt. outriggers down	Stabilizers raised	4 pt. outriggers down	Stabilizers raised	4 pt. outriggers down	Stabilizers raised	4 pt. outriggers down	Stabilizers raised	4 pt. outriggers down	Stabilizers raised	4 pt. outriggers down	Stabilizers raised	4 pt. outriggers down	ft	in
40	Stabilizers raised			17,8*	17,8*													13,9*	13,9*	18'	2"
40	4 pt. outriggers down			17,8*	17,8*													13,9*	13,9*		
35	Stabilizers raised					12,8	16,8	8,6	11,4									8,3	11,0	25'	6"
35	4 pt. outriggers down					17,4*	17,4*	12,3*	12,3*									11,3*	11,3*		
30	Stabilizers raised					13,0	17,1	9,0	11,8	6,3	8,5							6,2	8,3	30'	4"
30	4 pt. outriggers down					17,4*	17,4*	15,2*	15,2*	10,8*	10,8*							10,1*	10,1*		
25	Stabilizers raised					12,9	16,9	8,9	11,7	6,5	8,6							5,1	7,0		
25	4 pt. outriggers down					17,5*	17,5*	15,2*	15,2*	12,8	13,3*							9,6*	9,6*	33'	7"
20	Stabilizers raised			19,6	22,0*	12,4	16,4	8,7	11,5	6,3	8,5	4,7	6,5					4,5	6,2		
20	4 pt. outriggers down			22,0*	22,0*	18,2*	18,2*	15,5*	15,5*	12,7	13,4*	9,8	11,5*					9,3*	9,3*	36'	
15	Stabilizers raised	21,7*	21,7*	18,1	24,7	11,6	15,6	8,2	11,0	6,1	8,3	4,7	6,4					4,1	5,7		
15	4 pt. outriggers down	21,7*	21,7*	24,7*	24,7*	19,4*	19,4*	16,0*	16,0*	12,4	13,5*	9,7	11,4*					8,7	9,3*	37'	6"
10	Stabilizers raised	29,2	42,6*	16,1	22,4	10,7	14,6	7,7	10,5	5,8	7,9	4,5	6,2					3,9	5,4		
10	4 pt. outriggers down	42,6*	42,6*	27,5*	27,5*	20,5*	20,5*	15,9	16,4*	12,1	13,6*	9,5	11,2*					8,3	9,4*	38'	2"
5	Stabilizers raised	5,5*	5,5*	14,2	20,3	9,7	13,5	7,2	9,9	5,5	7,6	4,3	6,1					3,8	5,3		
5	4 pt. outriggers down	5,5*	5,5*	28,7*	28,7*	21,0*	21,0*	15,3	16,5*	11,7	13,3*	9,4	10,7*					8,2	8,5*	38'	5"
0	Stabilizers raised	6,5*	6,5*	13,1	19,1	9,0	12,8	6,7	9,4	5,3	7,4	4,2	5,9					3,8	5,4		
0	4 pt. outriggers down	6,5*	6,5*	21,2*	21,2*	20,2*	20,2*	14,8	15,7*	11,4	12,5*	9,2	9,6*					7,4*	7,4*	37'	10"
-5	Stabilizers raised			12,6	18,6	8,6	12,4	6,5	9,2	5,1	7,2	4,2	5,9					4,1	5,8		
-5	4 pt. outriggers down			19,8*	19,8*	17,8*	17,8*	14,0*	14,0*	10,9*	10,9*	7,6*	7,6*					7,0*	7,0*	35'	8"
-10	Stabilizers raised					8,6	12,3	6,4	9,1									5,5	7,7		
-10	4 pt. outriggers down					13,9*	13,9*	11,0*	11,0*									9,1*	9,1*	28'	5"

Height Can be slewed through 360° In longitudinal position of undercarriage Max. reach \* Limited by hydr. capacity

The lift capacities on the stick end without attachment are stated in lb x 1,000 and are valid on a firm, level supporting surface with blocked oscillating axle. These capacities can be slewed through 360° with the undercarriage in the transverse position. Capacities in the longitudinal position of the undercarriage (+/- 15°) are specified over the steering axle with the stabilizers raised and over the rigid axle with the stabilizers down. Indicated loads based on the ISO 10567 standard and do not exceed 75% of tipping or 87% of hydraulic capacity. The lift capacity of the unit is limited by its stability, the lifting capability of the hydraulic elements, or the maximum permissible lifting capacity of the load hook.

# LH 30 M – Equipment GA13

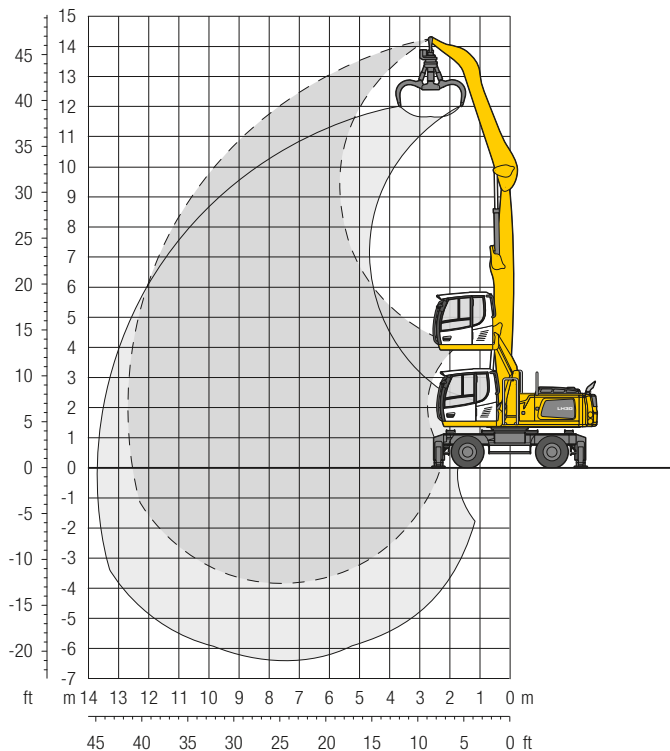

## Operating Weight

The operating weight includes the basic machine with 4 point outriggers, hydr. cab elevation, 8 solid tires plus intermediate rings, straight boom 23'11", angled stick 18'1" and multi-tine grab GM 65/0.78 yd<sup>3</sup> semi-closed tines.

Weight 63,300 lb

## Dimensions

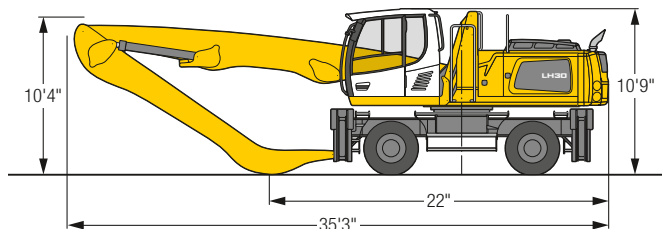

ft	10 ft		15 ft		20 ft		25 ft		30 ft		35 ft		40 ft		45 ft		ft in		
	Stabilizers raised	4 pt. outriggers down	Stabilizers raised	4 pt. outriggers down	Stabilizers raised	4 pt. outriggers down	Stabilizers raised	4 pt. outriggers down	Stabilizers raised	4 pt. outriggers down	Stabilizers raised	4 pt. outriggers down	Stabilizers raised	4 pt. outriggers down	Stabilizers raised	4 pt. outriggers down	Stabilizers raised	4 pt. outriggers down	
45																	15,0*	15,0*	14'11"
40					12,8	15,5*											8,9	11,1*	24' 5"
35					13,3	16,7*	9,1	11,9	6,3	8,5							6,2	8,4	30' 2"
30					16,7*	16,7*	14,6*	14,6*	10,0*	10,0*							9,6*	9,6*	
25					13,4	16,5*	9,2	12,0	6,6	8,8							4,9	6,7	34' 4"
20					16,5*	16,5*	14,3*	14,3*	12,7*	12,7*							8,9*	8,9*	
15					13,1	16,8*	9,0	11,9	6,5	8,7	4,8	6,6					4,1	5,7	37' 4"
10					16,8*	16,8*	14,5*	14,5*	12,7*	12,7*	9,9	11,2*					8,5*	8,5*	39' 5"
5					12,5	16,6	8,7	11,5	6,3	8,5	4,7	6,5					3,6	5,1	
0					17,6*	17,6*	14,9*	14,9*	12,7	12,8*	9,8	11,2*					8,0	8,3*	39' 5"
-5	18,0*	18,0*	18,2	24,1*	11,6	15,6	8,1	11,0	6,0	8,2	4,6	6,3	3,5	5,0			3,3	4,8	40'10"
-10	18,0*	18,0*	24,1*	24,1*	18,8*	18,8*	15,4*	15,4*	12,3	13,0*	9,6	11,1*	7,7	9,3*			7,5	8,3*	
	28,7	32,0*	15,8	22,2	10,5	14,3	7,5	10,3	5,6	7,8	4,3	6,1	3,4	4,9			3,1	4,5	41' 6"
	32,0*	32,0*	26,8*	26,8*	19,9*	19,9*	15,8	15,9*	11,9	13,2*	9,4	11,0*	7,6	9,0*			7,2	8,1*	
	3,9*	3,9*	13,6	19,7	9,3	13,1	6,9	9,6	5,2	7,4	4,1	5,8	3,3	4,7			3,1	4,5	41' 7"
	3,9*	3,9*	27,9*	27,9*	20,4*	20,4*	15,0	16,0*	11,5	13,0*	9,1	10,7*	7,5	8,4*			7,1	7,4*	
	4,8*	4,8*	12,3	16,0*	8,5	12,2	6,3	9,1	4,9	7,0	3,9	5,7	3,2	4,7			3,1	4,5	41' 1"
	4,8*	4,8*	16,0*	16,0*	19,8*	19,8*	14,4	15,5*	11,1	12,4*	8,9	10,0*	7,3*	7,3*			6,5*	6,5*	
			11,7	15,3*	8,0	11,7	6,0	8,7	4,7	6,8	3,8	5,5					3,3	4,7	39' 5"
			15,3*	15,3*	17,7*	17,7*	14,0*	14,0*	10,9	11,2*	8,6*	8,6*					5,9*	5,9*	
					7,9	11,6	5,9	8,6	4,6	6,7							3,9	5,7	
					14,3*	14,3*	11,6*	11,6*	9,0*	9,0*							6,9*	6,9*	34' 1"

Height Can be slewed through 360° In longitudinal position of undercarriage Max. reach \* Limited by hydr. capacity

The lift capacities on the stick end without attachment are stated in lb x 1,000 and are valid on a firm, level supporting surface with blocked oscillating axle. These capacities can be slewed through 360° with the undercarriage in the transverse position. Capacities in the longitudinal position of the undercarriage (+/- 15°) are specified over the steering axle with the stabilizers raised and over the rigid axle with the stabilizers down. Indicated loads based on the ISO 10567 standard and do not exceed 75% of tipping or 87% of hydraulic capacity. The lift capacity of the unit is limited by its stability, the lifting capability of the hydraulic elements, or the maximum permissible lifting capacity of the load hook.



# LH 30 M – Equipment GA14

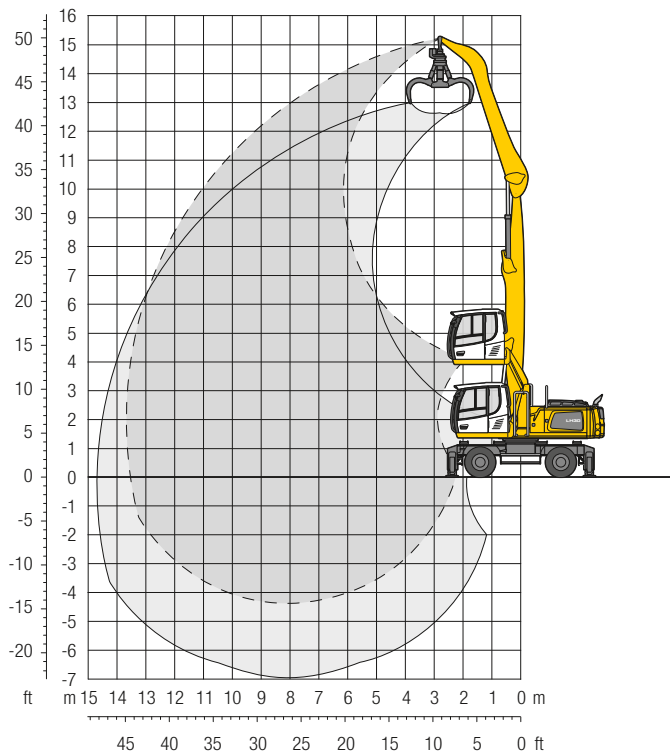

## Operating Weight

The operating weight includes the basic machine with 4 point outriggers, hydr. cab elevation, 8 solid tires plus intermediate rings, straight boom 25'7", angled stick 19'8" and multi-tine grab GM 65/0.78 yd<sup>3</sup> semi-closed tines.

Weight 63,700 lb

## Dimensions

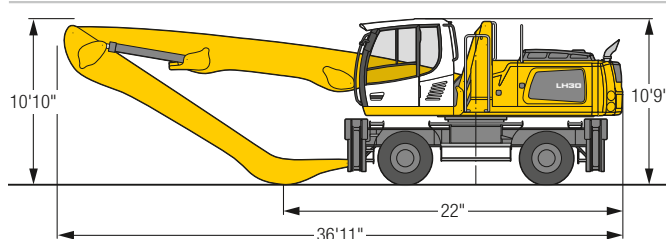

ft	10 ft		15 ft		20 ft		25 ft		30 ft		35 ft		40 ft		45 ft		ft in		
	Stabilizers raised	4 pt. outriggers down	Stabilizers raised	4 pt. outriggers down	Stabilizers raised	4 pt. outriggers down	Stabilizers raised	4 pt. outriggers down	Stabilizers raised	4 pt. outriggers down	Stabilizers raised	4 pt. outriggers down	Stabilizers raised	4 pt. outriggers down	Stabilizers raised	4 pt. outriggers down	ft	in	
45					12,6	13,6*											10,1	11,2*	22' 7"
40					13,4	15,8*	9,1	12,0									6,4	8,7	29' 7"
35					13,7	15,9*	9,4	12,3	6,7	8,9							4,8	6,6	34' 7"
30					15,9*	15,9*	13,8*	13,8*	12,2*	12,2*							8,4*	8,4*	
25							9,4	12,3	6,7	8,9	4,9	6,7					3,9	5,5	38' 2"
20					13,4	16,2*	9,2	12,1	6,6	8,8	4,9	6,6	3,6	5,0			7,9*	7,9*	40'11"
15					12,6	16,7	8,7	11,6	6,3	8,5	4,7	6,5	3,5	5,0			3,0	4,3	42'10"
10					17,1*	17,1*	14,4*	14,4*	12,4*	12,4*	9,8	10,8*	7,8	9,3*			6,9	7,5*	45' 5"
5					15,0*	15,0*	18,2	21,8*	11,6	15,6	8,1	10,9	5,9	8,1	4,5	6,2	3,4	4,9	44' 1"
0					15,0*	15,0*	21,8*	21,8*	18,3*	18,3*	15,0*	15,0*	12,3	12,6*	9,6	10,8*	7,7	9,2*	44' 8"
-5					21,3*	21,3*	15,6	21,9	10,3	14,2	7,3	10,1	5,5	7,6	4,2	5,9	3,2	4,7	44' 8"
-10					21,3*	21,3*	26,2*	26,2*	19,4*	19,4*	15,5*	15,5*	11,8	12,8*	9,3	10,8*	7,5	9,0*	44' 8"
					2,7*	2,7*	13,1	19,1	9,0	12,8	6,6	9,3	5,0	7,2	3,9	5,6	3,1	4,6	44' 10"
					2,7*	2,7*	22,6*	22,6*	19,9*	19,9*	14,8	15,6*	11,3	12,7*	8,9	10,5*	7,3	8,7*	44' 10"
					3,6*	3,6*	11,5	12,4*	8,0	11,8	6,0	8,7	4,6	6,7	3,7	5,4	2,9	4,4	44' 5"
					3,6*	3,6*	12,4*	12,4*	19,3*	19,3*	14,1	15,1*	10,8	12,2*	8,7	10,0*	7,2	8,0*	44' 5"
					5,8*	5,8*	10,8	12,1*	7,5	11,1	5,6	8,3	4,4	6,5	3,5	5,2	2,9	4,3	43' 1"
					5,8*	5,8*	12,1*	12,1*	17,4*	17,4*	13,6	13,9*	10,5	11,2*	8,5	9,0*	6,8*	6,8*	43' 1"
							10,7	13,7*	7,2	10,9	5,4	8,1	4,2	6,3	3,4	5,1			38' 8"
							13,7*	13,7*	14,5*	14,5*	11,8*	11,8*	9,5*	9,5*	7,3*	7,3*			38' 8"

Height Can be slewed through 360° In longitudinal position of undercarriage Max. reach \* Limited by hydr. capacity

The lift capacities on the stick end without attachment are stated in lb x 1,000 and are valid on a firm, level supporting surface with blocked oscillating axle. These capacities can be slewed through 360° with the undercarriage in the transverse position. Capacities in the longitudinal position of the undercarriage (+/- 15°) are specified over the steering axle with the stabilizers raised and over the rigid axle with the stabilizers down. Indicated loads based on the ISO 10567 standard and do not exceed 75% of tipping or 87% of hydraulic capacity. The lift capacity of the unit is limited by its stability, the lifting capability of the hydraulic elements, or the maximum permissible lifting capacity of the load hook.

# LH 30 M – Equipment GS10

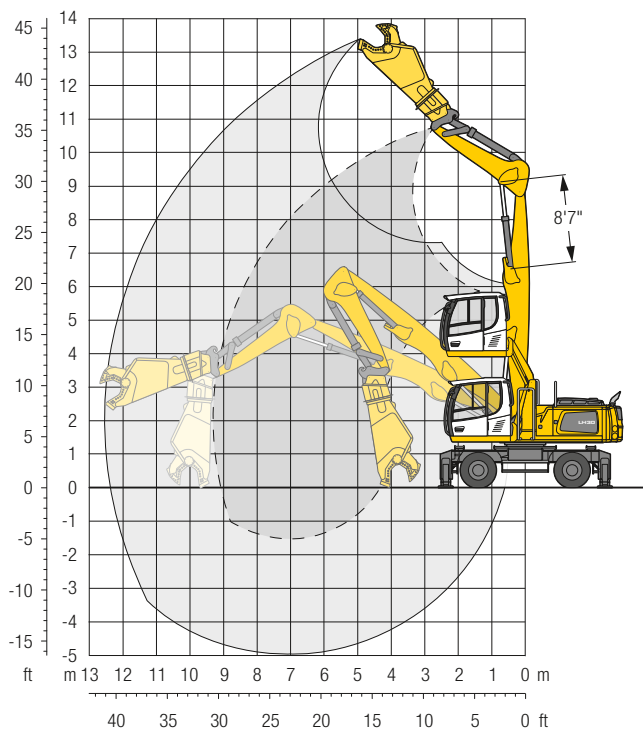

## Operating Weight

The operating weight includes the basic machine with 4 point outriggers, hydr. cab elevation, 8 solid tires plus intermediate rings, straight boom 22'4", stick HD with tipping kinematics special 10'6", quick coupler SWA 48 and scrap shear Genesis GXT 335R.

Weight 72,500 lb

A heavy counterweight (13,400 lb) is required for this attachment configuration.  
The stick cylinder must be limited to the measure of 8'7".

## Dimensions

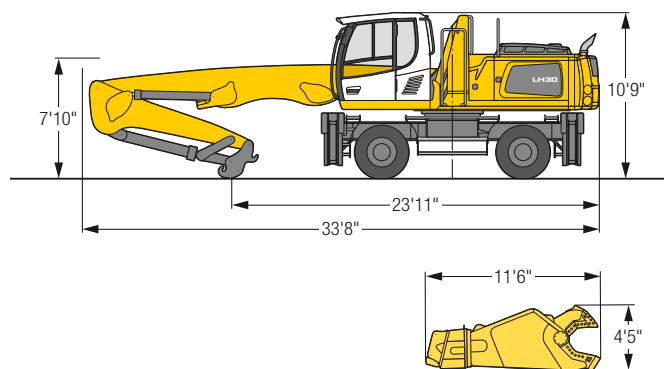

ft	10 ft		15 ft		20 ft		25 ft		30 ft		35 ft		40 ft		45 ft		ft in	
	Stabilizers raised	4 pt. outriggers down	Stabilizers raised	4 pt. outriggers down	Stabilizers raised	4 pt. outriggers down	Stabilizers raised	4 pt. outriggers down	Stabilizers raised	4 pt. outriggers down	Stabilizers raised	4 pt. outriggers down	Stabilizers raised	4 pt. outriggers down	Stabilizers raised	4 pt. outriggers down		
45					11,0*	11,0*											7,4	9,4*
40					11,0*	11,0*											9,4*	9,4*
35							6,7	8,2*									3,4	6,0
30							8,2*	8,2*									6,7*	6,7*
25							7,0	8,0*	3,4	5,9							1,5	3,6
20							8,0*	8,0*	6,3*	6,3*							5,3*	5,3*
15							6,8	8,0*	3,4	5,9	1,1	3,0					0,4	2,3
10							8,0*	8,0*	6,3*	6,3*	4,9*	4,9*					4,4*	4,4*
5							6,3	8,2*	3,1	5,5	0,9	2,9					-	1,4
0							8,2*	8,2*	6,4*	6,4*	4,8*	4,8*					3,7*	3,7*
-5					9,2*	9,2*	5,5	8,6*	2,6	5,0	0,6	2,6	-	0,8			-	0,8
-10					9,2*	9,2*	8,6*	8,6*	6,5*	6,5*	4,8*	4,8*	3,2*	3,2*			3,1*	3,1*
-15					6,7*	6,7*	8,6	12,4*	4,5	7,6	1,9	4,3	0,2	2,2			-	0,4
-20					6,7*	6,7*	12,4*	12,4*	9,0*	9,0*	6,6*	6,6*	4,7*	4,7*	3,0*	3,0*	2,6*	2,6*
-25					12,6	19,5*	6,6	10,9	3,3	6,4	1,2	3,6	-	1,7			-	0,4
-30					19,5*	19,5*	13,0*	13,0*	9,2*	9,2*	6,5*	6,5*	4,4*	4,4*	2,5*	2,5*	2,0*	2,0*
-35					-	-	9,2*	15,8	4,8	9,0	2,3	5,3	0,6	2,9	-		-	0,1
-40					-	-	19,5*	19,5*	12,9*	12,9*	8,9*	8,9*	6,1*	6,1*	3,9*	3,9*	1,7*	1,7*
-45					0,9*	0,9*	7,1	13,5*	3,6	7,6	1,5	4,4	0,1	2,4	-	1,0	-	0,1
-50					0,9*	0,9*	13,5*	13,5*	11,6*	11,6*	7,8*	7,8*	5,1*	5,1*	2,8*	2,8*	0,7*	0,7*
-55					3,6*	3,6*	6,2	12,6	2,9	6,9	1,0	3,9	-	2,1	-	0,9	-	-
-60					3,6*	3,6*	13,2*	13,2*	9,0*	9,0*	5,9*	5,9*	3,4*	3,4*	1,1*	1,1*	-	-
-65							2,7	5,2*	0,9	2,9*							-	0,8*
-70							5,2*	5,2*	2,9*	2,9*							0,8*	0,8*

**Height** **Can be slewed through 360°** **In longitudinal position of undercarriage** **Max. reach** \* Limited by hydr. capacity

The lift capacities on the stick end without attachment are stated in lb x 1,000 and are valid on a firm, level supporting surface with blocked oscillating axle. These capacities can be slewed through 360° with the undercarriage in the transverse position. Capacities in the longitudinal position of the undercarriage (+/- 15°) are specified over the steering axle with the stabilizers raised and over the rigid axle with the stabilizers down. Indicated loads based on the ISO 10567 standard and do not exceed 75% of tipping or 87% of hydraulic capacity. The maximum lift capacity for the quick coupler's load hook is 26,500 lb. Without attachment the lift capacity will increase by 7,716 lb and without quick coupler, tipping cylinder, lever and connection link by an additional 1,775 lb. The lift capacity of the unit is limited by its stability, the lifting capability of the hydraulic elements, or the maximum permissible lifting capacity of the load hook.

# LH 30 M – Equipment GSV13

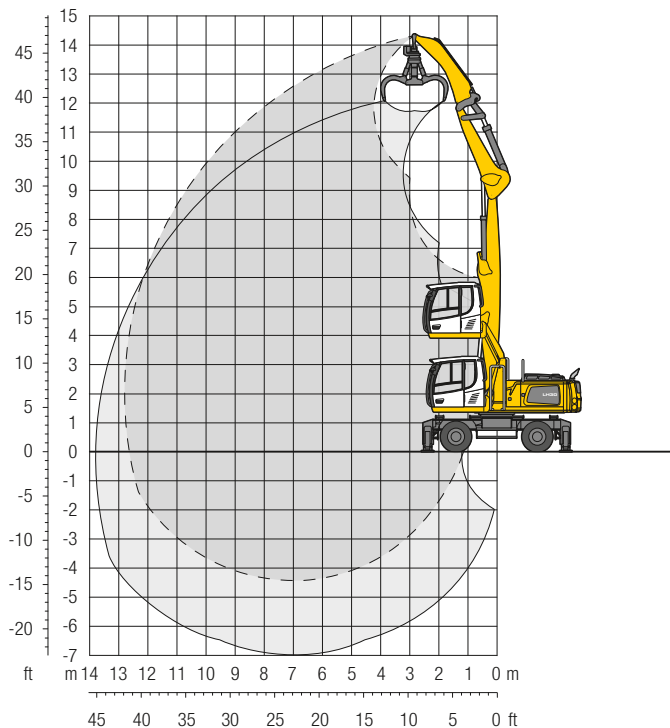

## Operating Weight

The operating weight includes the basic machine with 4 point outriggers, hydr. cab elevation, 8 solid tires plus intermediate rings, straight boom 22'4", stick HD with tipping kinematics special 10'6", quick coupler SWA 48, stick extension 8'10" and multi-tine grab GM 65/0.78 yd<sup>3</sup> semi-closed tines.

Weight 66,100 lb

A heavy counterweight (13,400 lb) is required for this attachment configuration.

## Dimensions

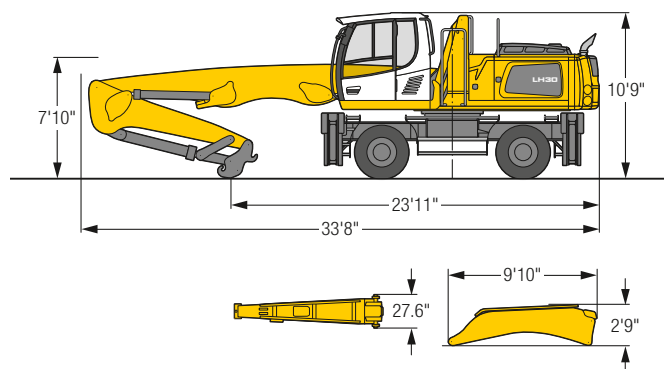

ft	10 ft		15 ft		20 ft		25 ft		30 ft		35 ft		40 ft		45 ft		ft in		
	Stabilizers raised	4 pt. outriggers down	Stabilizers raised	4 pt. outriggers down	Stabilizers raised	4 pt. outriggers down	Stabilizers raised	4 pt. outriggers down	Stabilizers raised	4 pt. outriggers down	Stabilizers raised	4 pt. outriggers down	Stabilizers raised	4 pt. outriggers down	Stabilizers raised	4 pt. outriggers down	ft	in	
45			14,3*	14,3*													12,3*	12,3*	16'11"
40					13,8*	13,8*	9,3	9,8*									8,8	9,0*	25' 7"
35					14,9*	14,9*	10,0	13,0*	6,7	9,1							6,0	7,6*	31' 2"
30					14,9*	14,9*	13,0*	13,0*	9,3*	9,3*							7,6*	7,6*	
25							10,2	12,6*	7,0	9,4	4,7	6,6					4,6	6,5	35' 2"
20							12,6*	12,6*	11,1*	11,1*	7,3*	7,3*					6,9*	6,9*	
15							10,1	12,6*	6,9	9,3	4,8	6,7					3,7	5,5	38' 1"
10							12,6*	12,6*	11,0*	11,0*	9,6*	9,6*					6,5*	6,5*	
5					14,5	15,2*	9,6	12,8	6,7	9,1	4,7	6,6	3,2	4,8			3,2	4,8	40' 2"
0					15,2*	15,2*	12,9*	12,9*	11,1*	11,1*	9,6*	9,6*	6,6*	6,6*			6,3*	6,3*	
-5					13,4	16,2*	9,0	12,1	6,3	8,6	4,5	6,4	3,1	4,8			2,8	4,3	41' 6"
-10					16,2*	16,2*	13,4*	13,4*	11,3*	11,3*	9,5*	9,5*	7,8	7,8*			6,2*	6,2*	
-15					15,0*	15,0*	19,2	22,9*	12,0	16,3	8,1	11,2	5,7	8,1	4,1	6,1	2,6	4,1	42' 2"
					15,0*	15,0*	22,9*	22,9*	17,3*	17,3*	13,8*	13,8*	11,4*	11,4*	9,4*	9,4*	6,3*	6,3*	
					19,2*	19,2*	16,0	22,9	10,4	14,6	7,2	10,2	5,2	7,5	3,8	5,7	2,8	4,4	42' 4"
					19,2*	19,2*	25,0*	25,0*	18,1*	18,1*	14,1*	14,1*	11,3*	11,3*	9,2*	9,2*	7,0*	7,0*	
					7,4*	7,4*	13,5	20,1	9,0	13,1	6,4	9,4	4,7	7,0	3,5	5,4	2,7	4,3	41'10"
					7,4*	7,4*	25,0*	25,0*	18,0*	18,0*	13,8*	13,8*	10,9*	10,9*	8,5*	8,5*	6,1*	6,1*	
					8,3*	8,3*	12,2	18,6	8,1	12,2	5,8	8,8	4,4	6,6	3,3	5,2	2,6	4,2	40' 6"
					8,3*	8,3*	21,3*	21,3*	16,6*	16,6*	12,7*	12,7*	9,8*	9,8*	7,4*	7,4*	4,4*	4,4*	
					10,5*	10,5*	11,7	18,0*	7,7	11,7	5,5	8,4	4,2	6,4	3,3	5,1	3,1	4,6*	40' 6"
					10,5*	10,5*	18,0*	18,0*	13,8*	13,8*	10,6*	10,6*	8,0*	8,0*	5,3*	5,3*	4,6*	4,6*	36' 2"

**Height** **Can be slewed through 360°** **In longitudinal position of undercarriage** **Max. reach** \* Limited by hydr. capacity

The lift capacities at the end of the stick extension without attachment are stated in lb x 1,000 and are valid on a firm, level supporting surface with blocked oscillating axle. These capacities can be slewed through 360° with the undercarriage in the transverse position. Capacities in the longitudinal position of the undercarriage (+/- 15°) are specified over the steering axle with the stabilizers raised and over the rigid axle with the stabilizers down. Indicated loads based on the ISO 10567 standard and do not exceed 75% of tipping or 87% of hydraulic capacity. The lift capacity of the unit is limited by its stability, the lifting capability of the hydraulic elements, or the maximum permissible lifting capacity of the load hook.



# LH 30 M – Equipment GK12

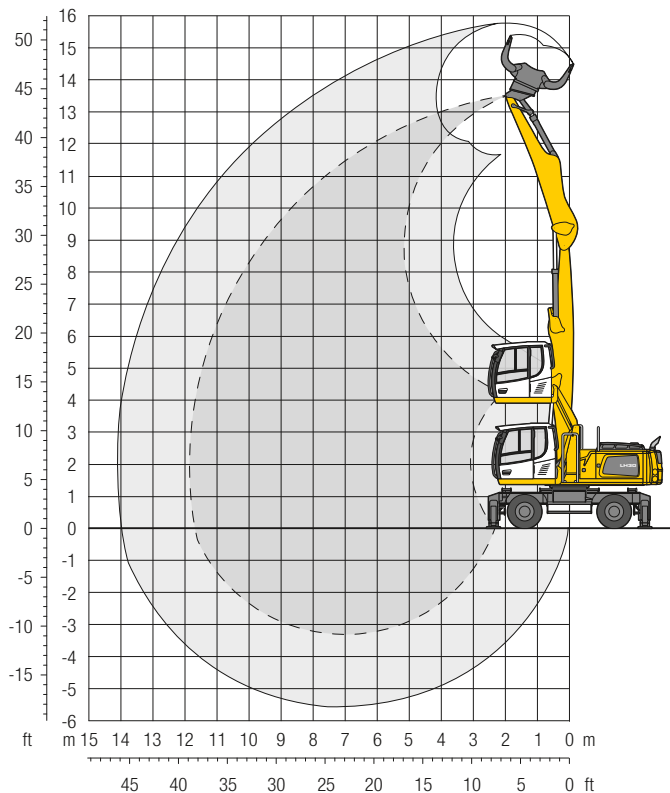

## Operating Weight

The operating weight includes the basic machine with 4 point outriggers, hydr. cab elevation, 8 solid tires plus intermediate rings, straight boom 22'4", stick with tipping kinematics 16'5" and sorting grab SG 30B/1.11 yd<sup>3</sup> perforated shells.

Weight 64,200 lb

## Dimensions

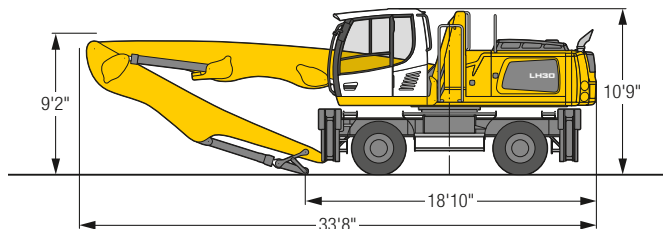

ft	10 ft		15 ft		20 ft		25 ft		30 ft		35 ft		40 ft		45 ft		ft in		
	Stabilizers raised	4 pt. outriggers down	Stabilizers raised	4 pt. outriggers down	Stabilizers raised	4 pt. outriggers down	Stabilizers raised	4 pt. outriggers down	Stabilizers raised	4 pt. outriggers down	Stabilizers raised	4 pt. outriggers down	Stabilizers raised	4 pt. outriggers down	Stabilizers raised	4 pt. outriggers down	Stabilizers raised	4 pt. outriggers down	
45																			
40			18,7	19,2*													12,0	14,0*	19' 4"
35			19,2*	19,2*													7,1	9,7	26' 4"
30					12,2	16,2	8,0	10,8									5,3	7,3	30'11"
25					17,2*	17,2*	13,6*	13,6*									9,8*	9,8*	
20					12,4	16,5	8,3	11,2	5,7	7,8							4,3	6,1	34' 2"
15					12,3	16,4	8,3	11,1	5,8	8,0							9,1*	9,1*	
10					16,8*	16,8*	14,4*	14,4*	12,2	12,6*							3,7	5,3	36' 6"
5			19,1	19,6*	11,8	15,8	8,0	10,9	5,7	7,9	4,1	5,8					8,4	8,7*	
0			19,6*	19,6*	17,5*	17,5*	14,7*	14,7*	12,0	12,6*	9,1	10,7*					7,8	8,6*	38'
-5	15,5*	15,5*	17,5	23,9*	11,0	15,0	7,6	10,4	5,4	7,6	4,0	5,7					3,1	4,6	38' 8"
-10	15,5*	15,5*	23,9*	23,9*	18,6*	18,6*	15,2*	15,2*	11,8	12,7*	9,0	10,6*					7,5	8,2*	
	28,5	28,8*	15,4	21,8	10,0	13,9	7,0	9,8	5,1	7,3	3,8	5,6					3,0	4,5	38'10"
	28,8*	28,8*	26,7*	26,7*	19,7*	19,7*	15,3	15,6*	11,4	12,8*	8,9	10,4*					7,2*	7,2*	
			13,4	19,5	9,0	12,8	6,5	9,2	4,8	6,9	3,7	5,4					3,1	4,6	38' 4"
			27,8*	27,8*	20,2*	20,2*	14,6	15,6*	11,0	12,5*	8,7	9,9*					6,1*	6,1*	
	3,7*	3,7*	12,2	17,4*	8,3	12,0	6,0	8,7	4,6	6,7	3,5	5,3					3,4	5,1	35' 8"
	3,7*	3,7*	17,4*	17,4*	19,3*	19,3*	14,1	14,9*	10,8	11,7*	8,5	8,8*					6,2*	6,2*	
			11,7	17,3*	7,9	11,6	5,7	8,4	4,4	6,5	3,5	5,2					4,7	7,0	
			17,3*	17,3*	16,9*	16,9*	13,2*	13,2*	10,0*	10,0*	6,8*	6,8*					8,2*	8,2*	28' 5"
					7,8	11,5	5,7	8,4											
					13,0*	13,0*	10,2*	10,2*											

**Height** **Can be slewed through 360°** **In longitudinal position of undercarriage** **Max. reach** \* Limited by hydr. capacity

The lift capacities on the stick end without attachment are stated in lb x 1,000 and are valid on a firm, level supporting surface with blocked oscillating axle. These capacities can be slewed through 360° with the undercarriage in the transverse position. Capacities in the longitudinal position of the undercarriage (+/- 15°) are specified over the steering axle with the stabilizers raised and over the rigid axle with the stabilizers down. Indicated loads based on the ISO 10567 standard and do not exceed 75% of tipping or 87% of hydraulic capacity. The lift capacity of the unit is limited by its stability, the lifting capability of the hydraulic elements, or the maximum permissible lifting capacity of the load hook.

# LH 35 M – Equipment GK13

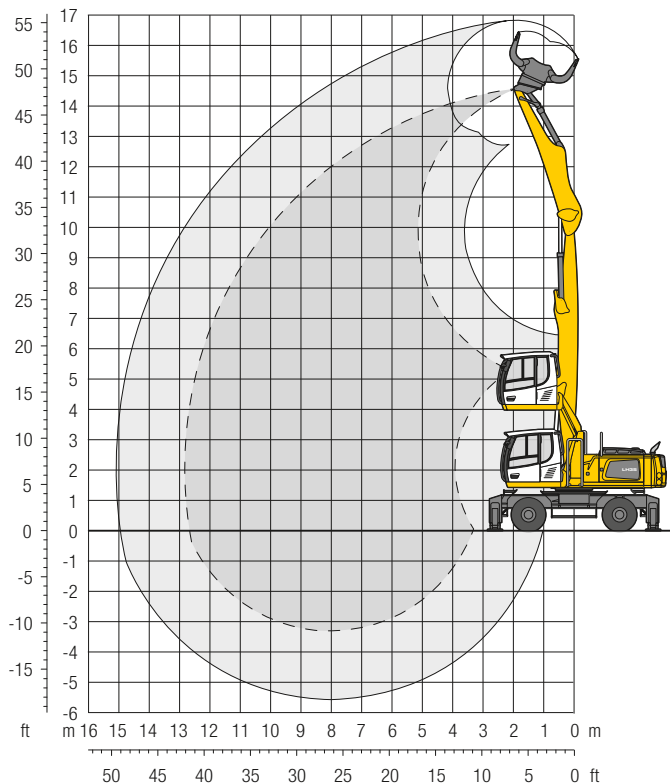

## Operating Weight

The operating weight includes the basic machine with 4 point outriggers, hydr. cab elevation, 8 solid tires plus intermediate rings, straight boom 25'7", stick with tipping kinematics 16'5" and sorting grab SG 30B/1.11 yd<sup>3</sup> perforated shells.

Weight 73,900 lb

## Dimensions

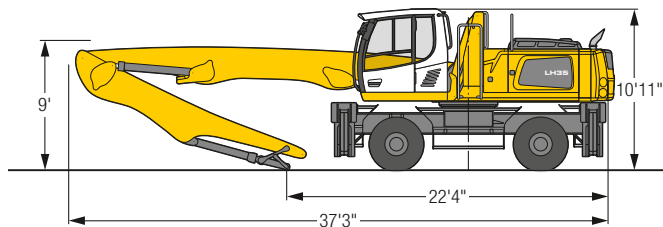

ft	10 ft		15 ft		20 ft		25 ft		30 ft		35 ft		40 ft		45 ft		ft in		
	Stabilizers raised	4 pt. outriggers down	Stabilizers raised	4 pt. outriggers down	Stabilizers raised	4 pt. outriggers down	Stabilizers raised	4 pt. outriggers down	Stabilizers raised	4 pt. outriggers down	Stabilizers raised	4 pt. outriggers down	Stabilizers raised	4 pt. outriggers down	Stabilizers raised	4 pt. outriggers down	Stabilizers raised	4 pt. outriggers down	
45			18,4*	18,4*													16,0*	16,0*	16'11"
40					16,3	17,1*	10,9	13,0*									10,4	11,9*	25' 7"
35					16,5*	16,5*	11,5	14,0*	8,1	10,5							7,5	9,7	31' 1"
30					16,4*	16,4*	11,5	13,9*	8,3	10,7	6,0	7,9					6,0	7,9	35' 1"
25					16,4*	16,4*	13,9*	13,9*	12,0*	12,0*	9,6*	9,6*					9,4*	9,4*	35'
20					16,3	16,8*	11,3	14,0*	8,2	10,6	6,1	8,0					5,1	6,8	38'
15					16,8*	16,8*	14,0*	14,0*	12,0*	12,0*	10,3*	10,3*					8,9*	8,9*	38'
10			21,2*	21,2*	15,5	17,7*	10,8	14,0	8,0	10,3	6,0	7,9	4,5	6,1			4,5	6,1	40'
5			21,2*	21,2*	17,7*	17,7*	14,4*	14,4*	12,1*	12,1*	10,3*	10,3*	8,3*	8,3*			8,3*	8,3*	40'
0	38,5*	38,5*	22,2	25,0*	14,4	18,7*	10,2	13,3	7,6	10,0	5,8	7,7	4,5	6,1			4,2	5,7	41' 4"
-5	38,5*	38,5*	25,0*	25,0*	18,7*	18,7*	14,8*	14,8*	12,2*	12,2*	10,2*	10,2*	8,3*	8,3*			7,5*	7,5*	41' 4"
-10			19,5	26,6*	13,1	17,4	9,5	12,5	7,2	9,5	5,6	7,5	4,4	6,0			4,0	5,5	42'
-15			26,6*	26,6*	19,3*	19,3*	15,1*	15,1*	12,2*	12,2*	10,0*	10,0*	7,9*	7,9*			6,7*	6,7*	42'
-20			7,4*	7,4*	12,0	16,2	8,9	11,9	6,8	9,1	5,4	7,2	4,3	5,9			3,9	5,4	42' 1"
-25			7,4*	7,4*	19,0*	19,0*	14,8*	14,8*	11,8*	11,8*	9,5*	9,5*	7,3*	7,3*			5,9*	5,9*	42' 1"
-30			7,2*	7,2*	11,3	15,5	8,4	11,4	6,5	8,8	5,2	7,0	4,2	5,8			4,0	4,9*	41' 6"
-35			7,2*	7,2*	17,5*	17,5*	13,8*	13,8*	11,0*	11,0*	8,6*	8,6*	6,1*	6,1*			4,9*	4,9*	41' 6"
-40			9,7*	9,7*	11,0	14,7*	8,1	11,1	6,3	8,6	5,1	6,9					4,4	5,0*	38'11"
-45			9,7*	9,7*	14,7*	14,7*	11,9*	11,9*	9,5*	9,5*	7,2*	7,2*					5,0*	5,0*	38'11"
-50							8,1	9,2*	6,3	7,2*							5,9	6,6*	31' 5"
-55							9,2*	9,2*	7,2*	7,2*							6,6*	6,6*	31' 5"

Height Can be slewed through 360° In longitudinal position of undercarriage Max. reach \* Limited by hydr. capacity

The lift capacities on the stick end without attachment are stated in lb x 1,000 and are valid on a firm, level supporting surface with blocked oscillating axle. These capacities can be slewed through 360° with the undercarriage in the transverse position. Capacities in the longitudinal position of the undercarriage (+/- 15°) are specified over the steering axle with the stabilizers raised and over the rigid axle with the stabilizers down. Indicated loads based on the ISO 10567 standard and do not exceed 75% of tipping or 87% of hydraulic capacity. The lift capacity of the unit is limited by its stability, the lifting capability of the hydraulic elements, or the maximum permissible lifting capacity of the load hook.

# LH 35 M – Equipment GA14

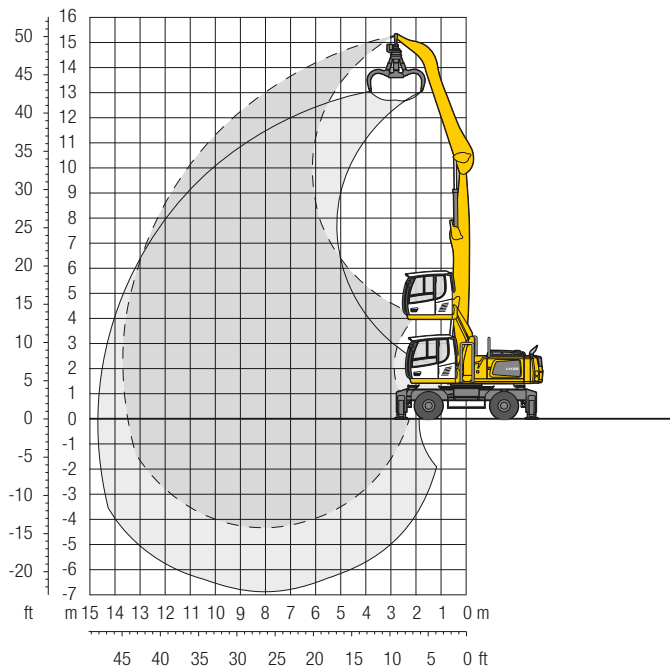

## Operating Weight

The operating weight includes the basic machine with 4 point outriggers, hydr. cab elevation, 8 solid tires plus intermediate rings, straight boom 25'7", angled stick 19'8" and multi-tine grab GM 65/0.78 yd<sup>3</sup> semi-closed tines.

Weight 73,000 lb

## Dimensions

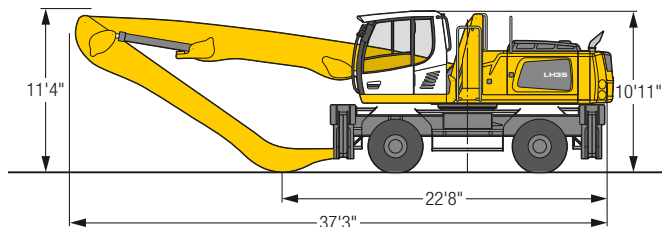

ft	Undercarriage	10 ft		15 ft		20 ft		25 ft		30 ft		35 ft		40 ft		45 ft		ft in		
		Stabilizers raised	4 pt. outriggers down	Stabilizers raised	4 pt. outriggers down	Stabilizers raised	4 pt. outriggers down	Stabilizers raised	4 pt. outriggers down	Stabilizers raised	4 pt. outriggers down	Stabilizers raised	4 pt. outriggers down	Stabilizers raised	4 pt. outriggers down	Stabilizers raised	4 pt. outriggers down	Stabilizers raised	4 pt. outriggers down	ft in
50	Stabilizers raised	17,8*	17,8*															17,6*	17,6*	10' 1"
45	Stabilizers raised	17,8*	17,8*			13,8*	13,8*											11,0*	11,0*	23'
40	Stabilizers raised					15,8*	15,8*	12,4	13,6*									8,9	9,3*	29'11"
35	Stabilizers raised					15,8*	15,8*	13,6*	13,6*	12,7	13,7*	9,3	11,7					6,9	8,4*	34'10"
30	Stabilizers raised							12,6	13,7*	12,7	13,7*	12,2*	12,2*					8,4*	8,4*	34'10"
25	Stabilizers raised							12,6	13,7*	12,7	13,7*	12,2*	12,2*	9,3	11,7	7,1	9,0	5,8	7,5	38' 4"
20	Stabilizers raised							13,7*	13,7*	13,7*	13,7*	12,1*	12,1*	10,7*	10,7*			7,9*	7,9*	38' 4"
15	Stabilizers raised					16,2*	16,2*	12,4	13,9*	12,7	13,7*	12,2*	12,2*	10,7*	10,7*	5,4	7,0	5,1	6,7	41'
10	Stabilizers raised	15,4*	15,4*	22,3*	22,3*	16,2*	16,2*	13,9*	13,9*	12,2*	12,2*	10,7*	10,7*	9,3*	9,3*			7,6*	7,6*	41'
5	Stabilizers raised	15,4*	15,4*	22,3*	22,3*	16,9	17,1*	11,9	14,4*	8,9	11,3	6,9	8,8	5,4	7,0			4,7	6,1	42'11"
0	Stabilizers raised	16,2*	16,2*	21,7	26,3*	17,1*	17,1*	14,4*	14,4*	12,4*	12,4*	10,8*	10,8*	9,3*	9,3*			7,5*	7,5*	42'11"
-5	Stabilizers raised	16,2*	16,2*	26,3*	26,3*	19,5*	19,5*	15,5*	15,5*	12,8*	12,8*	10,8*	10,8*	9,0*	9,0*			7,1*	7,1*	44'10"
-10	Stabilizers raised	2,6*	2,6*	19,2	21,2*	13,2	17,4	9,8	12,8	7,6	9,9	6,0	7,9	4,9	6,5			4,1	5,5	44'10"
-15	Stabilizers raised	2,6*	2,6*	21,2*	21,2*	19,9*	19,9*	15,6*	15,6*	12,7*	12,7*	10,5*	10,5*	8,6*	8,6*			6,4*	6,4*	44'10"
	Stabilizers raised	3,7*	3,7*	12,3*	12,3*	12,2	16,4	9,2	12,1	7,2	9,5	5,8	7,7	4,8	6,3			4,1	5,5	44' 4"
	4 pt. outriggers down	3,7*	3,7*	12,3*	12,3*	19,2*	19,2*	15,1*	15,1*	12,2*	12,2*	10,0*	10,0*	7,9*	7,9*			5,7*	5,7*	44' 4"
	Stabilizers raised	5,9*	5,9*	12,1*	12,1*	11,6	15,8	8,7	11,7	6,9	9,2	5,6	7,5	4,7	6,3			4,3	5,0*	42'11"
	4 pt. outriggers down	5,9*	5,9*	12,1*	12,1*	17,3*	17,3*	13,8*	13,8*	11,1*	11,1*	8,9*	8,9*	6,7*	6,7*			5,0*	5,0*	42'11"
	Stabilizers raised			13,8*	13,8*	11,4	14,3*	8,6	11,5	6,8	9,1	5,6	7,2*					5,0	5,7*	38' 5"
	4 pt. outriggers down			13,8*	13,8*	14,3*	14,3*	11,7*	11,7*	9,4*	9,4*	7,2*	7,2*					5,7*	5,7*	38' 5"

Height Can be slewed through 360° In longitudinal position of undercarriage Max. reach \* Limited by hydr. capacity

The lift capacities on the stick end without attachment are stated in lb x 1,000 and are valid on a firm, level supporting surface with blocked oscillating axle. These capacities can be slewed through 360° with the undercarriage in the transverse position. Capacities in the longitudinal position of the undercarriage (+/- 15°) are specified over the steering axle with the stabilizers raised and over the rigid axle with the stabilizers down. Indicated loads based on the ISO 10567 standard and do not exceed 75% of tipping or 87% of hydraulic capacity. The lift capacity of the unit is limited by its stability, the lifting capability of the hydraulic elements, or the maximum permissible lifting capacity of the load hook.



# LH 35 M – Equipment GA15

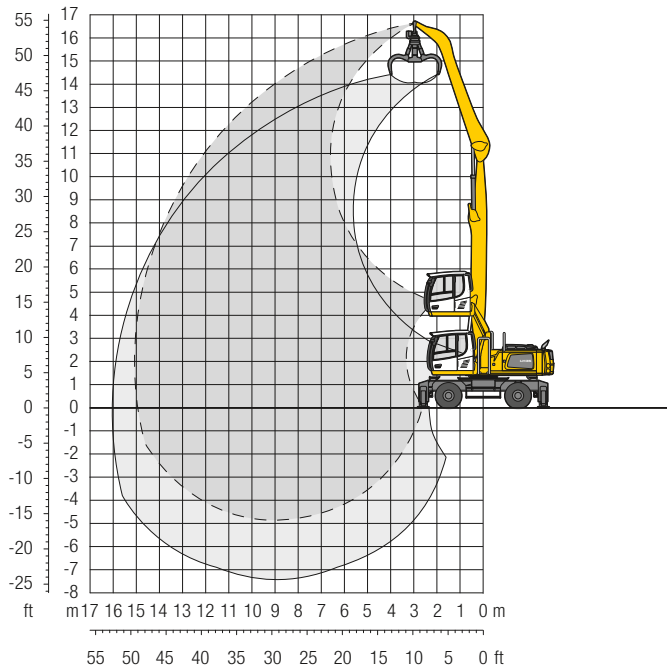

## Operating Weight

The operating weight includes the basic machine with 4 point outriggers, hydr. cab elevation, 8 solid tires plus intermediate rings, straight boom 28'7", angled stick 21'4" and multi-tine grab GM 65/0.78 yd<sup>3</sup> semi-closed tines.

Weight 73,900 lb

## Dimensions

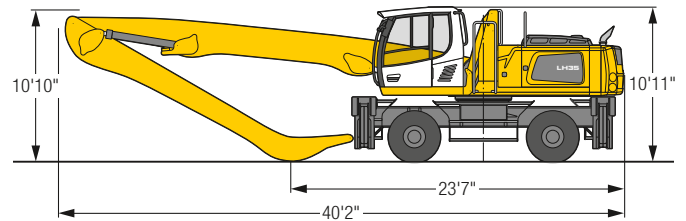

ft	Undercarriage	10 ft		15 ft		20 ft		25 ft		30 ft		35 ft		40 ft		45 ft		ft in		
		Stabilizers raised	4 pt. outriggers down	Stabilizers raised	4 pt. outriggers down	Stabilizers raised	4 pt. outriggers down	Stabilizers raised	4 pt. outriggers down	Stabilizers raised	4 pt. outriggers down	Stabilizers raised	4 pt. outriggers down	Stabilizers raised	4 pt. outriggers down	Stabilizers raised	4 pt. outriggers down	Stabilizers raised	4 pt. outriggers down	ft in
50	Stabilizers raised					13,1*	13,1*											10,6*	10,6*	23' 4"
	4 pt. outriggers down					13,1*	13,1*											10,6*	10,6*	
45	Stabilizers raised					14,7*	14,7*	12,5	13,0*	8,9	9,8*							8,3	8,8*	31'
	4 pt. outriggers down					14,7*	14,7*											8,8*	8,8*	
40	Stabilizers raised							12,9	13,1*	9,4	11,4*	6,9	8,8					6,3	7,8*	36' 5"
	4 pt. outriggers down							13,1*	13,1*	11,4*	11,4*	9,4*	9,4*					7,8*	7,8*	
35	Stabilizers raised							13,0	13,0*	9,5	11,3*	7,1	9,0	5,3	6,9			5,1	6,7	
	4 pt. outriggers down							13,0*	13,0*	11,3*	11,3*	10,0*	10,0*	8,0*	8,0*			7,3*	7,3*	40' 6"
30	Stabilizers raised							12,8	13,1*	9,4	11,3*	7,1	9,0	5,4	7,0			4,4	5,8	
	4 pt. outriggers down							13,1*	13,1*	11,3*	11,3*	10,0*	10,0*	8,8*	8,8*			7,0*	7,0*	43' 7"
25	Stabilizers raised					15,9*	15,9*	12,4	13,4*	9,1	11,5*	6,9	8,8	5,3	6,9	4,1	5,4	3,9	5,2	45' 11"
	4 pt. outriggers down					15,9*	15,9*	13,4*	13,4*	11,5*	11,5*	10,0*	10,0*	8,8*	8,8*	7,5*	7,5*	6,8*	6,8*	
20	Stabilizers raised					16,7	16,8*	11,7	13,8*	8,7	11,1	6,6	8,6	5,2	6,8	4,0	5,4	3,5	4,8	
	4 pt. outriggers down					16,8*	16,8*	13,8*	13,8*	11,7*	11,7*	10,1*	10,1*	8,8*	8,8*	7,5*	7,5*	6,7*	6,7*	47' 7"
15	Stabilizers raised	15,9*	15,9*	23,0*	23,0*	15,3	17,8*	10,8	14,0	8,1	10,5	6,3	8,2	4,9	6,5	3,9	5,3	3,3	4,5	48' 8"
	4 pt. outriggers down	15,9*	15,9*	23,0*	23,0*	17,8*	17,8*	14,3*	14,3*	11,9*	11,9*	10,2*	10,2*	8,7*	8,7*	7,4*	7,4*	6,2*	6,2*	
10	Stabilizers raised			20,2	25,5*	13,6	17,9	9,9	12,9	7,5	9,9	5,9	7,8	4,7	6,3	3,8	5,1	3,1	4,4	49' 4"
	4 pt. outriggers down			25,5*	25,5*	18,7*	18,7*	14,7*	14,7*	12,0*	12,0*	10,1*	10,1*	8,6*	8,6*	7,1*	7,1*	5,6*	5,6*	
5	Stabilizers raised			9,7*	9,7*	12,0	16,3	9,0	12,0	6,9	9,3	5,5	7,4	4,4	6,0	3,6	5,0	3,1	4,3	49' 4"
	4 pt. outriggers down			9,7*	9,7*	18,7*	18,7*	14,6*	14,6*	11,9*	11,9*	9,9*	9,9*	8,3*	8,3*	6,7*	6,7*	5,1*	5,1*	
0	Stabilizers raised	1,7*	1,7*	7,2*	7,2*	10,9	15,1	8,2	11,2	6,4	8,7	5,2	7,1	4,2	5,8	3,5	4,9	3,1	4,3	48' 11"
	4 pt. outriggers down	1,7*	1,7*	7,2*	7,2*	17,8*	17,8*	14,1*	14,1*	11,4*	11,4*	9,4*	9,4*	7,7*	7,7*	6,1*	6,1*	4,4*	4,4*	
-5	Stabilizers raised			8,0*	8,0*	10,3	14,4	7,7	10,7	6,1	8,4	4,9	6,8	4,1	5,6	3,4	4,8	3,2	3,7*	47' 11"
	4 pt. outriggers down			8,0*	8,0*	15,8*	15,8*	12,8*	12,8*	10,5*	10,5*	8,6*	8,6*	6,9*	6,9*	5,1*	5,1*	3,7*	3,7*	
-10	Stabilizers raised			9,6*	9,6*	10,0	13,0*	7,5	10,4	5,9	8,2	4,8	6,7	4,0	5,6			3,5	4,1*	44'
	4 pt. outriggers down			9,6*	9,6*	13,0*	13,0*	10,9*	10,9*	9,0*	9,0*	7,3*	7,3*	5,6*	5,6*			4,1*	4,1*	
-15	Stabilizers raised					7,4	8,3*	5,8	6,9*	4,8	5,4*							4,7	5,3*	
	4 pt. outriggers down					8,3*	8,3*	6,9*	6,9*	5,4*	5,4*							5,3*	5,3*	35' 5"

Height Can be slewed through 360° In longitudinal position of undercarriage Max. reach \* Limited by hydr. capacity

The lift capacities on the stick end without attachment are stated in lb x 1,000 and are valid on a firm, level supporting surface with blocked oscillating axle. These capacities can be slewed through 360° with the undercarriage in the transverse position. Capacities in the longitudinal position of the undercarriage (+/- 15°) are specified over the steering axle with the stabilizers raised and over the rigid axle with the stabilizers down. Indicated loads based on the ISO 10567 standard and do not exceed 75% of tipping or 87% of hydraulic capacity. The lift capacity of the unit is limited by its stability, the lifting capability of the hydraulic elements, or the maximum permissible lifting capacity of the load hook.

# LH 30 C LC – Equipment GK10

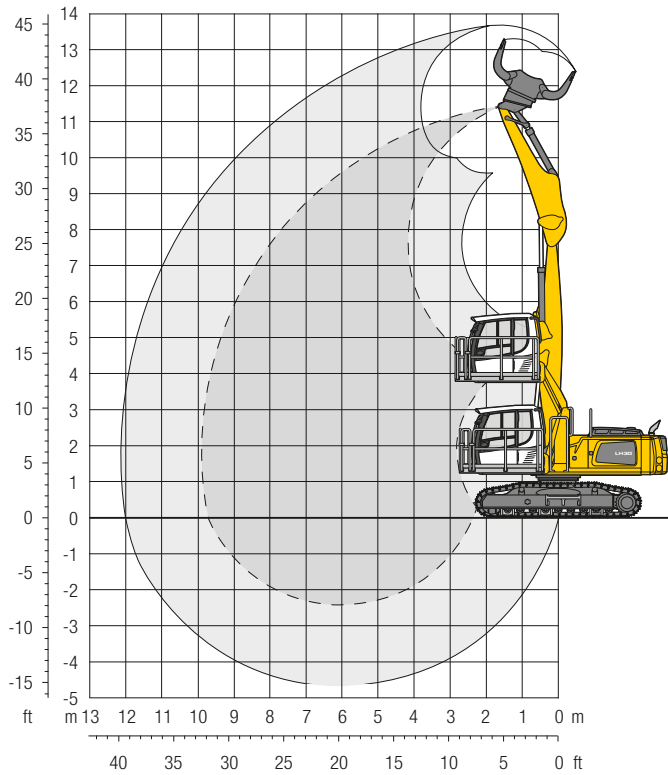

## Operating Weight and Ground Pressure

The operating weight includes the basic machine with hydr. cab elevation, straight boom 19', stick with tipping kinematics 13'1" and sorting grab SG 30B/1.11 yd<sup>3</sup> perforated shells.

Weight	65,300 lb
Pad width	24"
Ground pressure	on request

## Dimensions

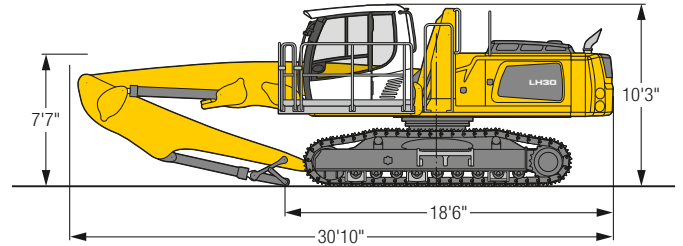

ft	Undercarriage	10 ft		15 ft		20 ft		25 ft		30 ft		35 ft		40 ft		45 ft		ft in		
35	LC	26,4*	26,4*															20,4*	20,4*	13' 4"
30	LC			23,3*	23,3*	16,1	18,3*											14,3	14,6*	21' 4"
25	LC			22,4*	22,4*	16,4	18,9*	11,3	16,2*									10,5	12,6*	26' 1"
20	LC			23,1*	23,1*	16,3	19,1*	11,4	16,2*									8,7	11,7*	29' 1"
15	LC	23,3*	23,3*	24,8	25,1*	15,8	19,9*	11,1	16,5*	8,3	12,9							7,8	11,3*	31' 1"
10	LC	42,6*	42,6*	23,3	27,9*	15,1	20,9*	10,8	16,7*	8,2	12,8							7,3	11,3*	32' 2"
5	LC	6,3*	6,3*	21,7	29,3*	14,3	21,3*	10,4	16,4*	8,0	12,5*							7,1	10,0*	32' 5"
0	LC	7,4*	7,4*	20,7	27,5*	13,8	20,2*	10,1	15,2*	7,9	10,8*							7,3	8,3*	31'11"
-5	LC			20,3	22,5*	13,5	17,1*	10,0	12,5*									8,5	9,3*	28' 5"

Height Can be slewed through 360° In longitudinal position of undercarriage Max. reach \* Limited by hydr. capacity

The lift capacities on the stick end without attachment are stated in lb x 1,000 and can be slewed through 360° on a firm, level supporting surface. Capacities are valid for 24" wide triple grouser pads. Indicated loads based on the ISO 10567 standard and do not exceed 75% of tipping or 87% of hydraulic capacity. The lift capacity of the unit is limited by its stability, the lifting capability of the hydraulic elements, or the maximum permissible lifting capacity of the load hook.

# LH 30 C LC – Equipment GA10

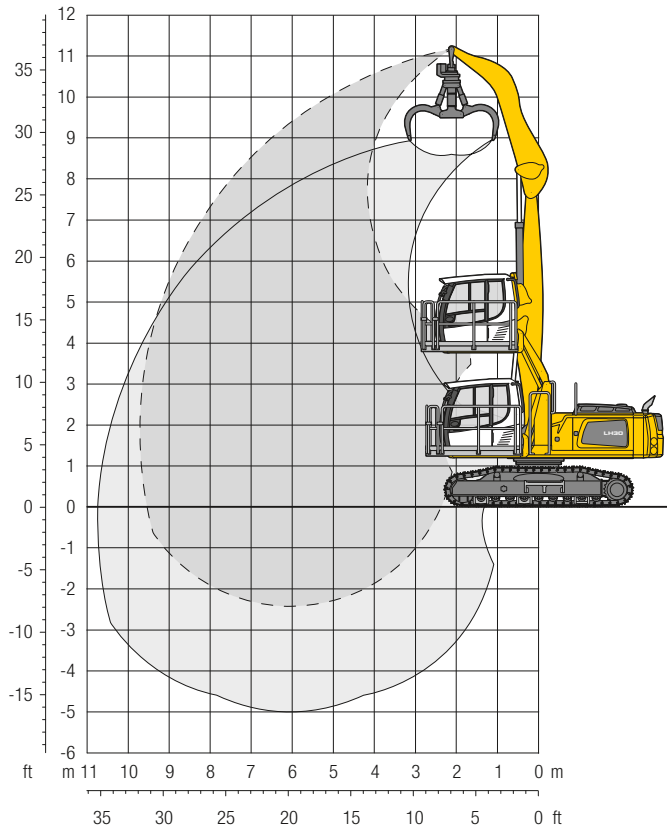

## Operating Weight and Ground Pressure

The operating weight includes the basic machine with hydr. cab elevation, straight boom 19', angled stick 13'1" and multi-tine grab GM 65/0.78 yd<sup>3</sup> semi-closed tines.

Weight	63,100 lb
Pad width	24"
Ground pressure	on request

## Dimensions

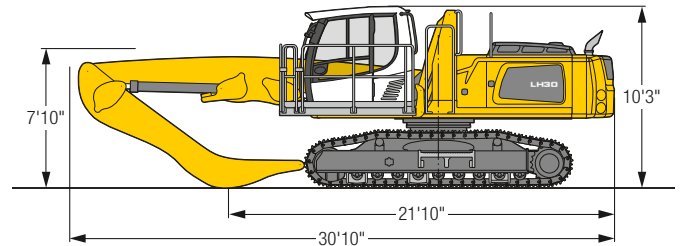

ft	Undercarriage	10 ft		15 ft		20 ft		25 ft		30 ft		35 ft		40 ft		45 ft		ft in		
35	LC	23,1*	23,1*															19,7*	19,7*	12'
30	LC			22,6*	22,6*	15,8*	15,8*											14,4*	14,4*	20' 6"
25	LC			23,0*	23,0*	16,9	19,6*	11,8	14,1*									11,5	12,8*	25' 5"
20	LC			23,7*	23,7*	16,8	19,8*	11,9	16,9*									9,6	12,1*	28' 7"
15	LC	29,5*	29,5*	25,3	25,8*	16,3	20,6*	11,7	17,1*	8,8	13,4							8,6	11,9*	30' 7"
10	LC	43,3*	43,3*	23,8	28,6*	15,6	21,6*	11,4	17,4*	8,7	13,3							8,1	12,1*	31' 8"
5	LC	12,0*	12,0*	22,3	30,1*	14,9	22,0*	11,0	17,0	8,6	13,1							7,9	11,4*	31'11"
0	LC	11,3*	11,3*	21,3	28,3*	14,4	20,9*	10,7	16,0*	8,5	11,5*							8,0	9,9*	31' 4"
-5	LC			21,0	23,3*	14,2	17,8*	10,6	13,3*									9,1	10,0*	28' 5"

Height Can be slewed through 360° In longitudinal position of undercarriage Max. reach \* Limited by hydr. capacity

The lift capacities on the stick end without attachment are stated in lb x 1,000 and can be slewed through 360° on a firm, level supporting surface. Capacities are valid for 24" wide triple grouser pads. Indicated loads based on the ISO 10567 standard and do not exceed 75% of tipping or 87% of hydraulic capacity. The lift capacity of the unit is limited by its stability, the lifting capability of the hydraulic elements, or the maximum permissible lifting capacity of the load hook.



# LH 30 C EW – Equipment GA12

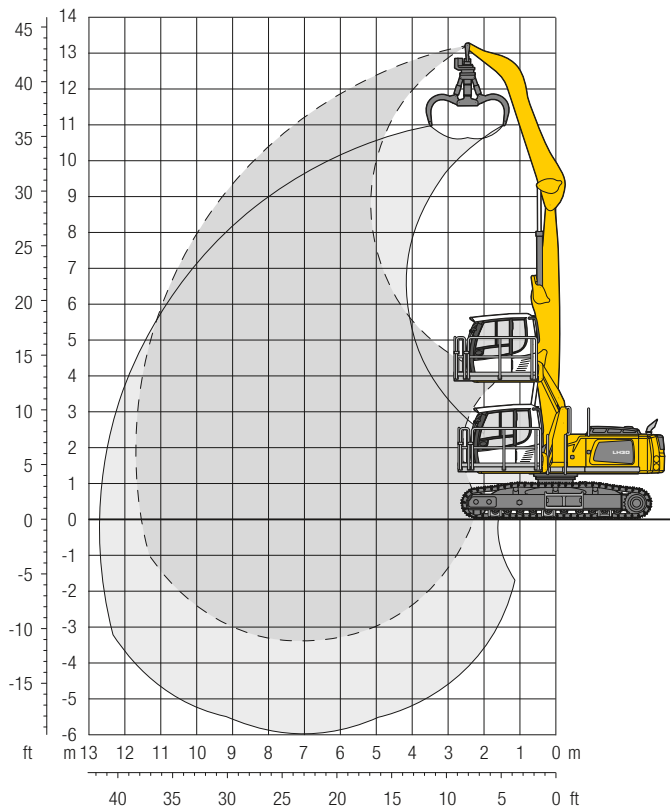

## Operating Weight and Ground Pressure

The operating weight includes the basic machine with hydr. cab elevation, straight boom 22'4", angled stick 16'5" and multi-tine grab GM 65/0.78 yd<sup>3</sup> semi-closed tines.

Weight	67,500 lb
Pad width	24"
Ground pressure	on request

## Dimensions

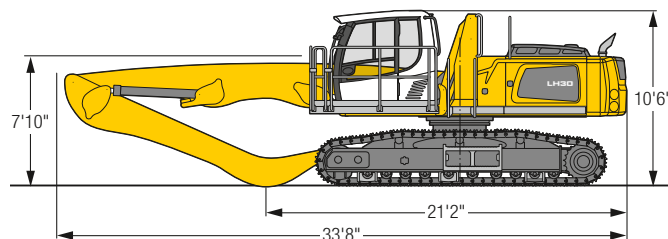

ft	Undercarriage	10 ft		15 ft		20 ft		25 ft		30 ft		35 ft		40 ft		45 ft		ft in			
		EW	EW	EW	EW	EW	EW	EW	EW	EW	EW	EW	EW	EW	EW	EW	EW	EW	EW		
45	EW																				
40	EW			17,3*	17,3*														14,3*	14,3*	17' 5"
35	EW					17,2*	17,2*	11,5*	11,5*										11,4*	11,4*	25' 1"
30	EW					17,4*	17,4*	15,2*	15,2*										10,2*	10,2*	30'
25	EW					17,5*	17,5*	15,1*	15,1*	13,3*	13,3*								9,6*	9,6*	33' 5"
20	EW			21,7*	21,7*	18,1*	18,1*	15,4*	15,4*	13,4*	13,4*	11,0	11,4*						9,3*	9,3*	35'10"
15	EW	20,9*	20,9*	24,5*	24,5*	19,3*	19,3*	15,9*	15,9*	13,5*	13,5*	10,9	11,4*						9,3*	9,3*	37' 5"
10	EW	42,1*	42,1*	27,3*	27,3*	20,5*	20,5*	16,4*	16,4*	13,5	13,6*	10,7	11,2*						9,4	9,4*	38' 2"
5	EW	5,7*	5,7*	28,7*	28,7*	21,0*	21,0*	16,5*	16,5*	13,2	13,3*	10,5	10,7*						8,6*	8,6*	38' 5"
0	EW	6,2*	6,2*	21,7*	21,7*	20,3*	20,3*	15,8*	15,8*	12,6*	12,6*	9,7*	9,7*						7,5*	7,5*	37'11"
-5	EW			19,8*	19,8*	18,1*	18,1*	14,2*	14,2*	11,0*	11,0*	7,8*	7,8*						7,0*	7,0*	36'
-10	EW					14,3*	14,3*	11,3*	11,3*										8,7*	8,7*	29' 5"

Height Can be slewed through 360° In longitudinal position of undercarriage Max. reach \* Limited by hydr. capacity

The lift capacities on the stick end without attachment are stated in lb x 1,000 and can be slewed through 360° on a firm, level supporting surface. Capacities are valid for 24" wide triple grouser pads. Indicated loads based on the ISO 10567 standard and do not exceed 75% of tipping or 87% of hydraulic capacity. The lift capacity of the unit is limited by its stability, the lifting capability of the hydraulic elements, or the maximum permissible lifting capacity of the load hook.

# LH 30 C EW – Equipment GA14

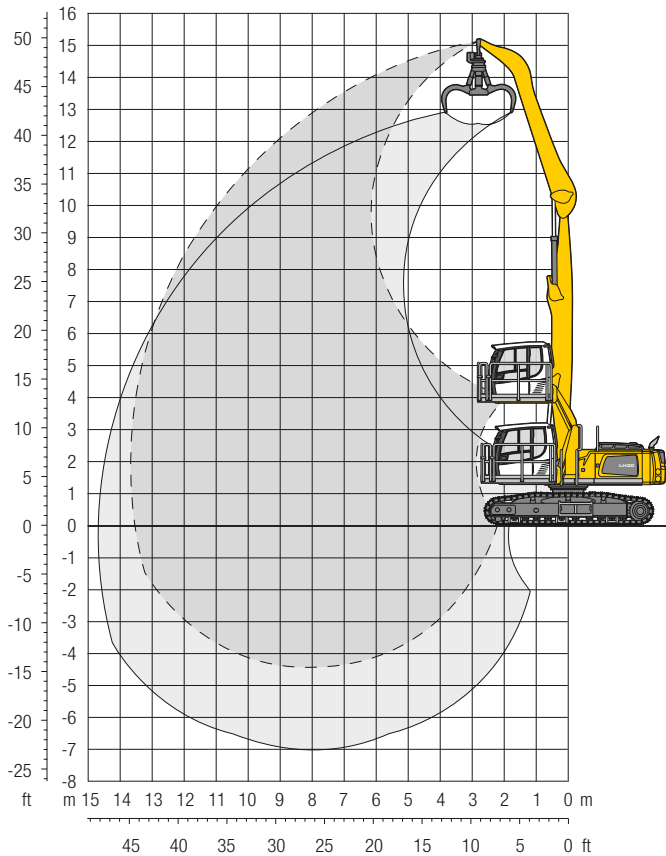

## Operating Weight and Ground Pressure

The operating weight includes the basic machine with hydr. cab elevation, straight boom 25'7", angled stick 19'8" and multi-tine grab GM 65/0.78 yd<sup>3</sup> semi-closed tines.

Weight	68,300 lb
Pad width	24"
Ground pressure	on request

## Dimensions

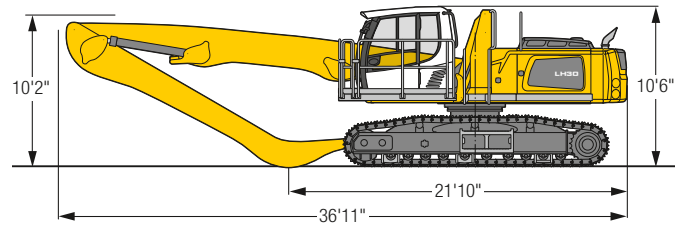

ft	Undercarriage	10 ft		15 ft		20 ft		25 ft		30 ft		35 ft		40 ft		45 ft		ft in		
		EW	EW	EW	EW	EW	EW	EW	EW	EW	EW	EW	EW	EW	EW	EW	EW	EW	EW	EW
45	EW					13,3*	13,3*											11,4*	11,4*	21'10"
40	EW					15,7*	15,7*	13,3*	13,3*									9,4*	9,4*	29' 2"
35	EW					15,9*	15,9*	13,8*	13,8*	12,2*	12,2*							8,5*	8,5*	34' 2"
30	EW							13,7*	13,7*	12,1*	12,1*	10,7*	10,7*					7,9*	7,9*	37'11"
25	EW					16,2*	16,2*	13,9*	13,9*	12,1*	12,1*	10,7*	10,7*	8,8	8,9*			7,6*	7,6*	40' 8"
20	EW					17,0*	17,0*	14,3*	14,3*	12,3*	12,3*	10,8*	10,8*	8,8	9,3*			7,5*	7,5*	42' 8"
15	EW			21,0*	21,0*	18,2*	18,2*	14,9*	14,9*	12,6*	12,6*	10,8	10,8*	8,7	9,2*			7,4	7,5*	44'
10	EW	40,4*	40,4*	26,0*	26,0*	19,3*	19,3*	15,4*	15,4*	12,8*	12,8*	10,5	10,8*	8,5	9,1*			7,1	7,2*	44' 8"
5	EW	2,8*	2,8*	25,4*	25,4*	19,9*	19,9*	15,6*	15,6*	12,7	12,7*	10,1	10,6*	8,3	8,7*			6,5*	6,5*	44'10"
0	EW	3,4*	3,4*	12,6*	12,6*	19,4*	19,4*	15,2*	15,2*	12,3	12,3*	9,9	10,0*	8,0*	8,0*			5,8*	5,8*	44' 5"
-5	EW	5,6*	5,6*	12,0*	12,0*	17,6*	17,6*	14,0*	14,0*	11,3*	11,3*	9,1*	9,1*	6,9*	6,9*			4,9*	4,9*	43' 4"
-10	EW			13,5*	13,5*	14,7*	14,7*	12,0*	12,0*	9,7*	9,7*	7,5*	7,5*					5,5*	5,5*	39' 2"

Height Can be slewed through 360° In longitudinal position of undercarriage Max. reach \* Limited by hydr. capacity

The lift capacities on the stick end without attachment are stated in lb x 1,000 and can be slewed through 360° on a firm, level supporting surface. Capacities are valid for 24" wide triple grouser pads. Indicated loads based on the ISO 10567 standard and do not exceed 75% of tipping or 87% of hydraulic capacity. The lift capacity of the unit is limited by its stability, the lifting capability of the hydraulic elements, or the maximum permissible lifting capacity of the load hook.

# LH 30 C EW – Equipment GK12

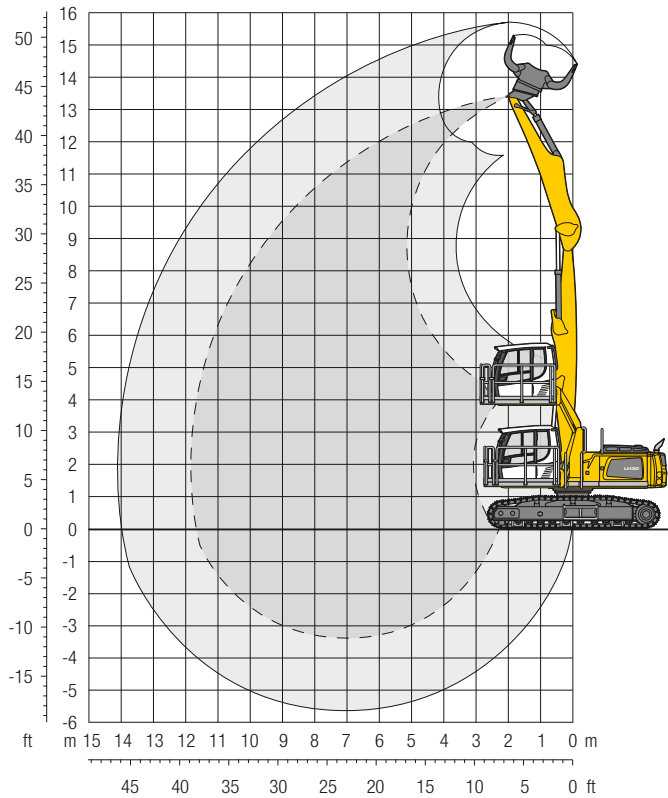

## Operating Weight and Ground Pressure

The operating weight includes the basic machine with hydr. cab elevation, straight boom 22'4", stick with tipping kinematics 16'5" and sorting grab SG 30B/1.11 yd<sup>3</sup> perforated shells.

Weight	69,700 lb
Pad width	24"
Ground pressure	on request

## Dimensions

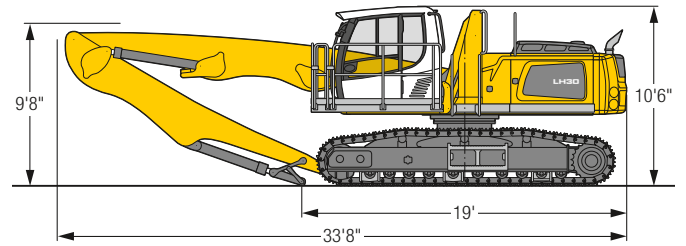

ft	Undercarriage	10 ft		15 ft		20 ft		25 ft		30 ft		35 ft		40 ft		45 ft		ft in		
40	EW			18,9*	18,9*													14,4*	14,4*	18' 6"
35	EW					17,3*	17,3*	13,0*	13,0*									11,2*	11,2*	25'10"
30	EW					16,7*	16,7*	14,5*	14,5*	11,4*	11,4*							9,9*	9,9*	30' 7"
25	EW					16,8*	16,8*	14,5*	14,5*	12,6*	12,6*							9,2*	9,2*	34'
20	EW			19,5*	19,5*	17,5*	17,5*	14,7*	14,7*	12,7*	12,7*	10,4	10,8*					8,8*	8,8*	36' 4"
15	EW	15,2*	15,2*	23,2*	23,2*	18,6*	18,6*	15,2*	15,2*	12,8*	12,8*	10,3	10,7*					8,6*	8,6*	37'11"
10	EW	41,3*	41,3*	26,6*	26,6*	19,7*	19,7*	15,7*	15,7*	12,8*	12,8*	10,2	10,5*					8,3*	8,3*	38' 8"
5	EW			27,9*	27,9*	20,2*	20,2*	15,7*	15,7*	12,6*	12,6*	10,0*	10,0*					7,3*	7,3*	38'10"
0	EW	3,4*	3,4*	17,8*	17,8*	19,5*	19,5*	15,1*	15,1*	11,8*	11,8*	9,0*	9,0*					6,2*	6,2*	38' 5"
-5	EW			17,1*	17,1*	17,3*	17,3*	13,4*	13,4*	10,3*	10,3*	7,1*	7,1*					6,2*	6,2*	36'
-10	EW					13,5*	13,5*	10,5*	10,5*									7,9*	7,9*	29' 5"

Height Can be slewed through 360° In longitudinal position of undercarriage Max. reach \* Limited by hydr. capacity

The lift capacities on the stick end without attachment are stated in lb x 1,000 and can be slewed through 360° on a firm, level supporting surface. Capacities are valid for 24" wide triple grouser pads. Indicated loads based on the ISO 10567 standard and do not exceed 75% of tipping or 87% of hydraulic capacity. The lift capacity of the unit is limited by its stability, the lifting capability of the hydraulic elements, or the maximum permissible lifting capacity of the load hook.



# Attachments

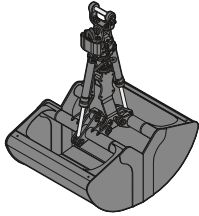

## Grab for Loose Material

Shells for loose material with cutting edge (without teeth)

### Grab model GM 20C

Width of shells	ft in	3'11"	4'11"	5'9"	6'7"	7'5"	8'2"
Capacity	yd <sup>3</sup>	1.57	1.96	2.29	2.62	2.94	3.27
Weight	lb	3,295	3,585	3,815	4,035	4,265	4,555

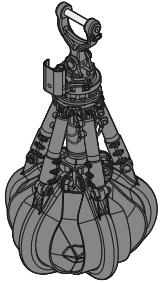

## Multi-Tine Grab

open

semi-closed

closed

### Grab model GM 64 (4 tines)

Capacity	yd <sup>3</sup>	0.52	0.78	0.52	0.78	0.52	0.78
Weight	lb	1,765	2,005	2,070	2,335	2,425	2,790

### Grab model GM 65 (5 tines)

Capacity	yd <sup>3</sup>	0.52	0.78	0.52	0.78	0.52	0.78
Weight	lb	2,590	2,890	2,975	3,285	3,010	3,540

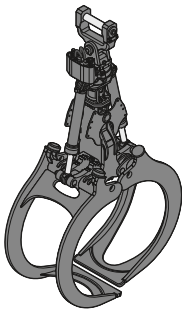

## Wood Grab

### Grab model GM 20B round-shaped (complete overlapping, vertical cylinders)

Size	yd <sup>2</sup>	1.20	1.55	1.79	2.03	2.27
Cutting width	ft in	2'8"	2'8"	2'8"	2'8"	2'8"
Height of grab, closed	ft in	8'5"	8'9"	8'11"	9'3"	9'6"
Weight	lb	3,405	3,470	3,515	3,585	3,880

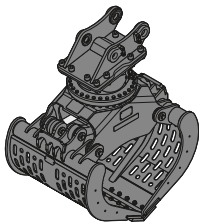

## Sorting Grab

ribbed

perforated

ribbed

perforated

ribbed

perforated

### Grab model SG 30B

Width of shells	ft in	3'3"	3'3"	3'11"	3'11"	4'7"	4'7"
Capacity	yd <sup>3</sup>	0.98	1.11	1.18	1.31	1.37	1.50
Max. closing force	lbf	17,985	17,985	17,985	17,985	17,985	17,985
Weight incl. adapter plate SWA	lb	3,890	3,715	4,135	3,880	4,365	4,045



## Load Hook

Max. load	lb	27,560
Height with suspension	ft in	3'1"
Weight	lb	300

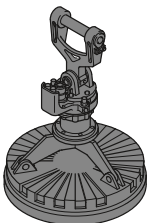



## Magnet Devices / Lifting Magnets

Generator	kW	13/17	13/17
<b>Electromagnet with suspension</b>			
Power	kW	8.8	10
Diameter of magnet	ft in	4'1"	4'5"
Weight	lb	2,890	3,750

\* only magnet plate

# Equipment

 Undercarriage	30 M	35 M	30 C
4-wheel steering		+	
Trailer coupling	+	+	
Track pads, variants			+
Individual control outriggers	+	+	
Shuttle axle lock, automatic	•	•	
Outrigger monitoring system	+	+	
Dozer blade	+	+	
Tires, variants	+	+	
Protection for travel drive	+	+	
Protection for piston rods, outriggers	+	+	
Two lockable storage compartments	•	•	
Undercarriage, variants			+

 Uppercarriage	30 M	35 M	30 C
Uppercarriage right side light, 1 piece, LED	•	•	•
Uppercarriage rear light, 2 pieces, LED	+	+	+
Refuelling system with filling pump	+	+	+
Railing on uppercarriage	+	+	+
Generator	+	+	+
Main battery switch for electrical system	•	•	•
Amber beacon, at uppercarriage, LED double flash	+	+	+
Protection for headlights	+	+	+
Protection for rear lights	+	+	+
Tool equipment, extended	+	+	+

 Hydraulic System	30 M	35 M	30 C
Electronic pump regulation	•	•	•
Liebherr hydraulic oil from -4 °F to +104 °F	•	•	•
Liebherr hydraulic oil, biologically degradable	+	+	+
Magnetic rod in hydraulic tank	•	•	•
Bypass filter	+	+	+
Preheating hydraulic oil	+	+	+

 Engine	30 M	35 M	30 C
Fuel anti-theft device	+	+	+
Air pre-filter with dust discharge	+	+	+
Automatic engine shut-down (time adjustable)	+	+	+
Preheating fuel	+	+	+
Preheating coolant	+	+	+
Preheating engine oil *	+	+	+

 Cooling System	30 M	35 M	30 C
Radiator, large-mesh, for dust-intensive operation	•	•	•
Reversible fan drive, fully automatic	+	+	+
Protective grid in front of cooler intake	•	•	•



## Operator's Cab

	30 M	35 M	30 C
Stabilizer, control lever, left console	+	+	
Stabilizer, proportional control on left joystick	•	•	
Cab lights rear, halogen	+	+	+
Cab lights rear, LED	+	+	+
Cab lights front, halogen	+	+	+
Cab lights front, halogen (under rain cover)	•	•	•
Cab lights front, LED	+	+	+
Cab lights front, LED (under rain cover)	+	+	+
Armrest adjustable	•	•	•
Slewing gear brake Comfort, button on the left or right joystick	+	+	+
Operator's seat Comfort	•	•	•
Operator's seat Premium	+	+	+
Driving alarm			
(acoustic signal is emitted during travel, can be switched ON/OFF)	+	+	+
Fire extinguisher	+	+	+
Footrest	+	+	+
Horn, button on left joystick	•	•	•
Joystick steering (max. 7.5 mph)	•	•	
Joystick and wheel steering (slim version)	+	+	
Cab elevation, hydraulic (LHC)	•	•	•
Cab elevation, rigid (LFC)	+	+	+
Automatic air conditioning	•	•	•
Wheel steering (slim version)	+	+	
LiDAT, vehicle fleet management	•	•	•
Proportional control	•	•	•
Radio Comfort, control via display with handsfree set	+	+	+
Preparation for radio installation	•	•	•
Back-up alarm			
(acoustic signal is emitted traveling backward, can not be switched off)	+	+	
Amber beacon, on cabin, LED double flash	+	+	+
Windows made from impact-resistant laminated safety glass	+	+	+
Windscreen wiper, roof	+	+	+
Windshield wiper, entire windscreen	•	•	•
Top guard	+	+	+
Front guard, adjustable	+	+	+
Sun visor	+	+	+
Left control console, folding	•	•	•



## Equipment

	30 M	35 M	30 C
Boom lights, 2 pieces, halogen	•	•	•
Boom lights, 2 pieces, LED	+	+	+
Stick lights, 2 pieces, halogen	•	•	•
Stick lights, 2 pieces, LED	+	+	+
Filter system for attachment	+	+	+
Height limitation and stick shutoff, electronically	+	+	+
Boom cylinder cushioning	+	+	+
Stick camera (with separate monitor), bottom side, with protection	+	+	+
Liebherr multi coupling system	+	+	+
Liebherr quick coupler, hydraulic	+	+	+
Pipe fracture safety valves hoist cylinders	•	•	•
Pipe fracture safety valves stick cylinders	•	•	•
Quick coupling system LIKUFIX	+	+	+
Quick coupling system MH 40B	+	+	+
Protection for piston rods, hoist cylinder	+	+	+
Overload warning device	+	+	+



## Complete Machine

	30 M	35 M	30 C
<b>Lubrication</b>			
Lubrication undercarriage, manually – decentralized (grease points)	•	•	
Lubrication undercarriage, manually – centralized (one grease point)	+	+	
Central lubrication system for uppercarriage and equipment, automatically	•	•	•
Central lubrication system for undercarriage, automatically	+	+	
Central lubrication system, extension for attachment	+	+	+
<b>Special coating</b>			
Special coating, variants	+	+	+
<b>Monitoring</b>			
Rear view monitoring with camera	•	•	•
Side view monitoring with camera	•	•	•

• = Standard, + = Option

\* = country-dependent

Options and/or special equipments, supplied by vendors other than Liebherr, are only to be installed with the knowledge and approval of Liebherr in order to retain warranty.



# The Liebherr Group of Companies



## Diverse Product Range

The Liebherr Group is one of the largest construction equipment manufacturers in the world. Liebherr's quality products and services hold a high reputation in many industries. The wide range includes domestic appliances, aerospace and transportation systems, machine tools and maritime cranes.

## Exceptional Customer Benefit

Every product line provides a complete range of models in many different versions. With both their technical excellence and superior quality, Liebherr products offer customers the highest benefits in practical applications.

## State-of-the-art Technology

Liebherr attributes great importance to the product areas of core technology and components, in order to achieve its consistent, top-quality products. Important modules and components are developed and manufactured in-house, for instance, the entire drive and control technology for the construction equipment and mining trucks.

## Worldwide and Family-Owned

Hans Liebherr founded the Liebherr family company in 1949. Since that time, the enterprise has steadily grown to a group of more than 130 companies with more than 46,000 employees located on all continents. The corporate headquarters of the Group is Liebherr-International AG in Bulle, Switzerland. The Liebherr family is the sole owner of the company.

[www.liebherr.us](http://www.liebherr.us)

## Liebherr USA, Co.

Construction Equipment Division  
4100 Chestnut Avenue, Newport News, VA 23607, USA  
☎ +1 (757) 245 5251, Fax +1 (757) 928 8701  
[www.liebherr.us](http://www.liebherr.us), E-Mail: [Construction.USA@liebherr.com](mailto:Construction.USA@liebherr.com)  
[www.facebook.com/LiebherrConstruction](https://www.facebook.com/LiebherrConstruction)