

# Wheeled Excavator

## A 914

Litronic®

### Operating Weight

32,100 – 37,900 lb

### Engine

141 HP / 105 kW  
Stage Tier 4f

### Bucket Capacity

0.22 – 1.14 yd<sup>3</sup>



# LIEBHERR



## Performance

Durably Stable Power,  
Strength and Precision

## Economy

A Sound Investment – Optimum Economy  
and Environmentally Friendly

### Operating Weight

32,100 – 37,900 lb

### Engine

141 HP / 105 kW

Stage Tier 4f

### Bucket Capacity

0.22 – 1.14 yd<sup>3</sup>





## Reliability

Competence, Consistency,  
Innovation – Proven Experience

## Comfort

Ergonomic Excellence – Superior Cabin  
Designed for Operator Comfort and Wellbeing

## Maintainability

Service Every Step of the Way –  
Simple, Fast and Reliable





# Performance



## Durably Stable Power, Strength and Precision

Liebherr wheeled excavators are designed for maximum productivity. Large grab capacity, high payloads and rapid working cycles satisfy all the requirements for efficient site operations. A wide range of attachments enhances excavator use.

## Maximum Performance

### Uncompromising Power

The machine concept of the A 914 Litronic is designed for maximum capacity and flexibility. A powerful construction machine engine and the brilliant coordination of the uppercarriage and undercarriage as well as attachments to counterweight, ensures that the machine handles superbly, delivering power and stability at all times in any situation. In addition, a range of different job-related attachments and tools enables the A 914 to adapt perfectly to different areas of work.

### Working Faster

Many years of experience in the development and production of hydraulic excavators and systems allow us to coordinate the components perfectly. As a result, Liebherr hydraulic excavators feature rapid, fluent movements combined with high precision. These properties are also available when simply driving the machine. The speed and position of the machine can be adjusted using the MODE switch to suit a new task, which also saves fuel.



## Precise Work

### Working with Precision

The Liebherr joysticks enable the operator to intuitively and sensitively control the Liebherr hydraulic system to complete even the most challenging tasks quickly, not only with reduced speed but also with maximum power output. Liebherr has been using an infinitely variable proportional controller with four axes for many years. The slim, ergonomically designed proportional sensors deliver additional functionality to the classic machine controller without having to reach for additional controls. Typical functions include high and medium pressure movements for tools, the control of height and sideways-adjustable booms as well as lowering the machine outrigger.

The mini-joysticks can also be used to steer the entire machine. Buttons on the joysticks, which the operator can configure, deliver additional convenience and functions.

### Travel Drive

- High traction for fast acceleration and powerful engine for top speed on hills
- Reduces unproductive travel time between tasks and on the building site
- Faster on site – More productive

### Digging Force

- High digging and breakout forces
- Continuously high digging performance even in tough ground
- More digging force for faster results

### Joystick Steering

- The optional joystick steering function enables the operator to steer the wheeled excavator using the mini-joystick
- Working and travelling movements can be executed simultaneously without having to move hands
- More efficient operation for greater productivity



# Economy



## A Sound Investment – Optimum Economy and Environmentally Friendly

Liebherr wheeled excavators are machines that combine high productivity with excellent levels of economy – and all this comes standard from the factory. On request, the efficiency of each wheeled excavator can be boosted further with a Liebherr productive bucket, fuel-saving Liebherr hydraulic oil or a Liebherr quick coupling system, all of which provide more return from each operating hour.

## Maximum Efficiency

### Fuel Savings from the Latest Generation of Engines

Liebherr uses a sturdy four-cylinder in-line engine in the A 914 Litronic which is powerful, fuel-efficient and reliable. Liebherr has decades of expertise in the research and development of construction machinery engines, which is used to ensure that these requirements are satisfied. Despite low fuel consumption, the engine does not suffer any reduction in performance. Standard features such as automatic engine shut-down and engine speed adjustment on the joystick increase efficiency even more whilst also protecting the material. An investment that pays dividends immediately.

### Low Maintenance SCR

The D924 diesel engine protects the environment and its resources by reducing its emissions. Liebherr uses an innovative SCR (selective catalytic reduction), consisting of an SCR catalytic converter system and other components, such as an injector and AdBlue® supply, to achieve emissions stage Tier 4f. This reduces emissions of nitrogen oxides (NO<sub>x</sub>) by over 90 percent. Liebherr also supplies an additional particulate filter as an option if required.

## Increased Productivity

### Faster, More Effective Site Operations

The A 914 packs plenty of power and delivers excellent productivity and economy in operation. Great engine performance, high load capacity and reliable stability with a considerable reach deliver a massive operating radius. The benefit is a high speed, focused operation without frequent machine movements.

### Efficient Management

LiDAT, Liebherr's own data transmission and positioning system, facilitates efficient management, monitoring and control of the entire fleet in terms of machinery data recording, data analysis, fleet management and service. All of the important machinery data can be viewed at any time on a web browser. LiDAT provides you comprehensive work deployment documentation, greater availability thanks to shorter downtimes, faster support from the manufacturer, quicker detection of strain/overload and subsequently a longer service life of the machine as well as greater planning efficiency.

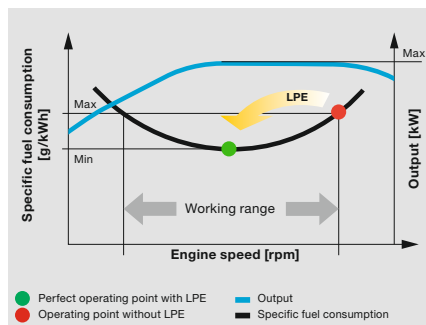

### High Resale Value

- High quality materials and quality workmanship ensure lengthy operation whilst retaining the highest possible value

### Low Fuel Consumption Thanks to Intelligent Machine Control

- Liebherr-Power Efficiency (LPE) optimises the interaction of the drive components in terms of efficiency
- LPE enables machine operation in the area of the lowest specific fuel use for reduced consumption and greater efficiency with the same performance

### Liebherr Quick Coupling System LIKUFIX

- Faster and safer changing of mechanical and hydraulic working tools from the operator's cabin
- Machine utilization increased to up to 90 % thanks to extended deployment options
- Visual and acoustic check of correct locking position of tool at quick coupling system by two proximity sensors



# Reliability



## Competence, Consistency, Innovation – Proven Experience

Reliability offers safety. Safety that significantly influences the success of a project. Whatever the weather, Liebherr stands for safety – with reliable construction machines and customer-oriented sales and service partners. This means a Liebherr construction machine is exactly what it should be: an investment that pays off.



## High Machine Availability

### Quality and Competence

Our product experience, our understanding of technical design and feedback from customers, along with sales and service, form the basis for the use of pioneering ideas and have always been an integral part of our recipe for success. In addition, Liebherr has been delivering great production depth and system solutions for decades. Key components such as the electronic components, slewing ring, slewing drive and hydraulic cylinders are developed and manufactured in-house. This great production depth guarantees the highest quality possible and allows the components to be coordinated perfectly.

### Robust Construction

All the steel components are designed and manufactured by Liebherr. High strength steel sheets designed to withstand the harshest requirements guarantee high torsion resistance and excellent absorption of forces to ensure a long service life.

## Greater Safety

### Safety

In addition to the performance and economy of a wheeled excavator, the other main focus is on the safety of personnel and the machine. A wide range of equipment such as pipe fracture safety devices on lifting and stick cylinders, load holding valves on outriggers, lift limitation in height, overload warning device, roll-over protection system (ROPS) and the emergency exit through the rear window deliver maximum safety for every job.

### Liebherr Tires

The twin tires without an intermediate ring and with offset studs deliver increased stability during operation. In addition, the increased tire pressure ensures that the machine suffers less vibration during travel.

Higher traction on soft ground and lower ground pressure are achieved by the larger footprint of Liebherr tires. The self-cleaning tread pattern guides dirt out of the tires during rotation which prevents tracking debris onto the road surface.



### All-round Visibility

- Skyview 360° camera system for easy monitoring of the danger zones around the machine
- Less down time due to lower accident and damage risk
- Increased safety and flexibility in restricted spaces

### Integral Travel Drive Protection

- The travel motor and gearbox are fully integrated in the robust undercarriage frame
- Best possible protection from debris, stones and soil in the event of unwanted ground contact
- Perfect off-road features and massive ground clearance

### Maximum Stability

- Various undercarriage versions with securely welded outriggers deliver safe footing, maximum stability and a long service life
- Support/Bulldozer blade in box design; just two bearings deliver high torsion resistance
- Optional piston rod guard for blade and support



# Comfort



## Ergonomic Excellence – Superior Cabin Design for Operator Comfort and Wellbeing

The modern Liebherr cab with an air-suspension heated driver's seat and automatic air-conditioning ensures a pleasant atmosphere, thus offering the best conditions for healthy and productive work while allowing the driver to work with full concentration. The ergonomic control elements with touch-screen display also simplify the operation of the wheeled excavator. The extensive safety equipment includes the rollover protection system (ROPS) for the cab fitted as standard according to ISO 12117-2.



## First-class Cab

### Automatic Air Conditioning

Liebherr fits the A 914 with a standard automatic air conditioning system to ensure operator comfort. The temperature, fan setting and the various air vents at head, chest and foot levels can be adjusted through the intuitive operation of the touchscreen. The defrost/defog one-button function clears fogged windows in the shortest possible time. The filter for the cab air can be changed easily and conveniently from outside.

### Operator Seats

The Standard, Comfort and Premium operator's seat versions deliver maximum comfort. Even the standard operator seat offers an extensive range of features such as air suspension, seat heating, headrest, lumbar support and many more. A luxury which we believe every construction machine should provide.

### Smooth Operation

The use of visco-elastic mounts, good noise insulation and modern, smooth Liebherr diesel engines minimize noise emissions and vibrations.

## Comfortable Operation

### Radio with Hands-free Device

The optional Liebherr radio is MP3-compatible, has a USB connection and can be used as interface for the integral hands-free kit. If the machine operator connects his smartphone to the radio using Bluetooth, the touchscreen can be used to control phone calls. This means that all media, including the radio, MP3 or phone calls, are controlled using a central unit which provides greater clarity, simplicity and comfort.

### Control Unit

The large touchscreen provides the operator with a fast, uncomplicated interface which delivers all the information required for working with the machine. A flat, intuitive menu system ensures that it can be readily understood so that the control unit can be used in a highly productive way.

### Sliding Two-Piece Windscreen

The windscreen can be partially or fully slid into the roof to give an unrestricted view of the work area.



### Refueling

- Using the optional refueling pump, the machine can be refueled directly from a fuel container
- An integral tank hose and an automatic shut off when the tank is full deliver greater comfort and short refueling times
- Topping up – simple, quick and safe

### Maximum Safety

- More convenient and safer entry and exit in and out of the cab thanks to added width from the folding arm console
- Three entry steps with standard anti-slip galvanized plates provide a boost to safety

### Intuitive Operation

- Display of the machine data and camera image on the 7-inch indicating unit with touchscreen and direct access via menu bar
- 20 user-programmable memory slots for working tools, which can be used for quickly and easily setting the oil pressure and oil flow at the push of a button when changing tools
- Rear and side area monitoring provide optimum visibility of the working area at all times; equipped as standard



# Maintainability



## Service Every Step of the Way – Simple, Fast and Reliable

Liebherr compact wheeled excavators are not only powerful, robust, precise and efficient, they also impress with the service-orientated machine design. Maintenance is performed quickly, simply and safely. This reduces maintenance costs and keeps machine downtimes to a minimum.



# Simplified Maintenance Concept

## Service-based Machine Design

The service-based machine design guarantees short servicing times, thus minimizing maintenance costs due to the time it saves. All the maintenance points are easily accessible from the ground and easy to reach due to the large, wide-opening service doors. The enhanced service concept places the maintenance points close to each other. This means that service work can be completed even more quickly and efficiently.

## Hydraulic Oils with Added Value

Liebherr hydraulic oils achieve a service life of 6,000 operating hours plus. Instead of having defined change intervals, the results of the oil analysis (every 1,000 operating hours or after one year) determine when the oil needs to be changed. The unique Liebherr Hydraulic Plus oil can even achieve a service life of 8,000 operating hours plus at the same time reducing fuel consumption by up to 5%.

# Your Competent Service Partner

## Remanufacturing

The Liebherr remanufacturing program offers cost-effective reconditioning of components to the highest quality standards. Various reconditioning levels available including replacement components and general overhaul or repair. The customer receives components with original part quality at a reduced cost.

## Competent Advice and Service

Competent advice is a given at Liebherr. Experienced specialists provide advice for your specific requirements: application-oriented sales support, service agreements, cost-effective repair alternatives, original parts management, as well as remote data transmission for machine planning and fleet management.



## Lubrication During Operation

- Fully automatic central lubrication system for the attachment and swing ring
- Can be expanded to the connecting link and quick coupler
- Lubrication without interrupting work for higher productivity

## Excellent Service Access

- Large, wide-opening service doors
- Engine oil, fuel, air and cab air filters are easily and safely accessible from the ground
- The oil level in the hydraulic tank can be checked from the cab
- Standard magnetic rod in the hydraulic tank as reliable service indicator

## Rapid Spare Parts Service

- 24-hour delivery: Spare parts service is available for our dealers around the clock
- Electronic spare parts catalog: Fast and reliable selection and ordering via the Liebherr online portal
- With online tracking, the current processing status of your order can be viewed at any time



# Wheeled Excavator A 914 Litronic

## Overview

### Excellent Machine Concept for Maximum Reliability

- Robust design made of high strength steel
- Various welded outrigger versions available
- Load holding valves on all outriggers
- Liebherr hydraulic cylinders with standard pipe fracture safety devices for lifting and stick cylinders
- Overload warning device
- Roll-over protection system (ROPS)
- Electronic lift limitation (optional)
- Integral travel drive protection
- Liebherr twin tires (optional)
- Skyview 360° – Camera system

### Ergonomic Operator's Work Station for Maximum Comfort

- High quality operator's seats in a range of versions
- Control console connected to the seat and ergonomic joysticks
- Folding control console, left
- Proportional control with 4-way mini-joystick
- Joystick steering (optional)
- Automatic air-conditioning system (optional)
- Information center – 7" large color touchscreen
- Rear and side monitor
- Convenient radio control with hands-free kit
- Tool Control for working tools
- LED headlights (optional)
- Large windows
- Sliding two-piece windscreen





### **Superior Technology for Highest Economy**

- Diesel engine compliant with stage Tier 4f
- Emissions treatment with Liebherr-SCR technology
- Liebherr-Power-Efficiency (LPE) – Liebherr's smart engine controller
- Load-sensing-control
- Liebherr quick coupling system LIKUFIX
- LiDAT – Liebherr's information system for the efficient management and evaluation of the fleet

### **Perfect Combination for Highest Possible Performance**

- Powerful 4-cylinder in-line engine with Common-Rail injection system
- Liebherr hydraulic system for high digging and breakout forces with combined, fluid movements
- Flexible configuration of the machine with various attachment and tool versions and options
- Wide undercarriage measuring 9' (optional)

### **Simplified Maintenance Concept for Maximum Productivity**

- Service-enhanced machine structure with easy access to the maintenance points
- Fully automatic central lubrication system for uppercarriage, slewing ring and attachments
- Liebherr Hydraulic Plus – oil with an extended service life of up to 8,000 operating hours
- Highly qualified, experienced trained personnel provide competent care
- 24/7 Spare parts service with 24 hour deliveries



# Technical Data



## Diesel Engine

<b>Rating per SAE J1349/ISO 9249</b>	141 HP (l) (105 kW) at 1,800 rpm
<b>Model</b>	D924 – FPT motor designed for Liebherr
<b>Type</b>	4 cylinder in-line
<b>Bore/Stroke</b>	4.1/5.2 in
<b>Displacement</b>	274.6 in <sup>3</sup>
<b>Engine operation</b>	4-stroke diesel Common-Rail turbo-charged and after-cooled reduced emissions
<b>Air cleaner</b>	dry-type air cleaner with pre-cleaner, primary and safety elements
<b>Engine idling</b>	sensor controlled
<b>Electrical system</b>	
Voltage	24 V
Batteries	2 x 135 Ah/ 12 V
Alternator	three-phase current 28 V/ 140 A
<b>Stage Tier 4f</b>	
Harmful emissions values	in accordance with EPA/CARB-40CFR stage Tier 4f
Emission control	Liebherr-SCR technology
Option	Liebherr particle filter
Fuel tank	66 gal
Urea tank	12 gal



## Cooling System

<b>Diesel engine</b>	water-cooled compact cooling system consisting cooling unit for water, hydraulic oil and charge air with stepless thermostatically controlled fan, fans for radiator cleaning can be completely folded away
----------------------	--



## Hydraulic Controls

<b>Power distribution</b>	via control valves with integrated safety valves, simultaneous and independent actuation of chassis, swing drive and equipment
<b>Servo circuit</b>	
Equipment and swing	with hydraulic pilot control and proportional joystick levers
Chassis	electroproportional via foot pedal
<b>Additional functions</b>	via switch or electroproportional foot pedals
<b>Proportional control</b>	proportionally acting transmitters on the joysticks for additional hydraulic functions



## Hydraulic System

<b>Hydraulic pump</b>	Liebherr axial piston variable displacement pump
for equipment and travel drive	
Max. flow	66 gpm
Max. pressure	5,076 psi
<b>Hydraulic pump regulation and control</b>	Liebherr-Synchron-Comfort-system (LSC) with electronic engine speed sensing regulation, pressure and flow compensation, torque controlled swing drive priority
<b>Hydraulic tank</b>	34.5 gal
<b>Hydraulic system</b>	max. 79.5 gal
<b>Hydraulic oil filter</b>	1 main return filter with integrated partial micro filtration (5 µm)
<b>MODE selection</b>	adjustment of engine and hydraulic performance via a mode pre-selector to match application, e.g. for especially economical and environmentally friendly operation or for maximum digging performance and heavy-duty jobs
S (Sensitive)	mode for precision work and lifting through very sensitive movements
E (Eco)	mode for especially economical and environmentally friendly operation
P (Power)	mode for high performance with low fuel consumption
P+ (Power-Plus)	mode for highest performance and for very heavy duty applications, suitable for continuous operation
<b>Engine speed and performance setting</b>	stepless alignment of engine output and hydraulic power via engine speed
Option	Tool Control: 20 preadjustable pump flows and pressures for add-on attachments



## Swing Drive

<b>Drive</b>	Liebherr axial piston motor with integrated brake valve and torque control, Liebherr planetary reduction gear
<b>Swing ring</b>	Liebherr, sealed race ball bearing swing ring, internal teeth
<b>Swing speed</b>	0 – 10.0 rpm stepless
<b>Swing torque</b>	39,828 lbf ft
<b>Holding brake</b>	wet multi-disc (spring applied, pressure released)
<b>Option</b>	pedal controlled positioning swing brake



## Operator's Cab

<b>Cab</b>	ROPS safety cab structure (roll-over protection system) with individual windscreens or featuring a slide-in subpart under the ceiling, work headlights integrated in the ceiling, a door with a sliding window (can be opened on both sides), large stowing and depositing possibilities, shock-absorbing suspension, sounddamping insulating, tinted laminated safety glass, separate window shades for the sunroof window and windscreen
<b>Operator's seat Standard</b>	air cushioned operator's seat with 3D-adjustable armrests, headrest, lap belt, seat heater, manual weight adjustment, adjustable seat cushion inclination and length and mechanical lumbar vertebrae support
<b>Operator's seat Comfort (Option)</b>	in addition to operator's seat standard: lockable horizontal suspension, automatic weight adjustment, adjustable suspension stiffness, pneumatic lumbar vertebrae support and passive seat climatization with active coal
<b>Operator's seat Premium (Option)</b>	in addition to operator's seat comfort: active electronic weight adjustment (automatic re-adjustment), pneumatic low frequency suspension and active seat climatization with active coal and ventilator
<b>Control system</b>	joysticks with control consoles and swivel seat, folding left control console
<b>Operation and displays</b>	large high-resolution operating unit, self-explanatory, color display with touchscreen, video-compatible, numerous setting, control and monitoring options, e.g. air conditioning control, fuel consumption, machine and attachment parameters
<b>Air-conditioning</b>	automatic air-conditioning, recirculated air function, fast de-icing and demisting at the press of a button, air vents can be operated via a menu; recirculated air and fresh air filters can be easily replaced and are accessible from the outside; heating-cooling unit, designed for extreme outside temperatures, sensors for solar radiation, inside and outside temperatures (country-dependent)



## Undercarriage

<b>Drive</b>	oversized two speed power shift transmission with additional creeper speed, Liebherr axial piston motor with functional brake valve on both sides
<b>Pulling force</b>	21,357 lbf
<b>Travel speed</b>	0 – 2.2 mph stepless (creeper speed off-road) 0 – 4.3 mph stepless (off-road) 0 – 8.1 mph stepless (creeper speed on-road) 0 – 12.4 mph stepless (road travel) 0 – max. 23.0 mph Speeder (Option)
<b>Driving operation</b>	automotive driving using accelerator pedal, cruise control function: storage of variable accelerator pedal positions, both off-road and on-road
<b>Axes</b>	manual or automatic hydraulically controlled front axle oscillation lock
<b>Service brake</b>	two circuit travel brake system with accumulator; wet and backlash-free disc brake
<b>Automatic digging brake</b>	works automatically when driving off (accelerator pedal actuation) and when the machine is stationary (engagement); the digging brake engages automatically – can be coupled with automatic swing axle lock
<b>Holding brake</b>	wet multi-disc (spring applied, pressure released)
<b>Stabilization</b>	rear stabilizer blade (adjustable during travel for dozing) rear outriggers + front stabilizer blade rear + front stabilizer blade
<b>Option</b>	EW-undercarriage 9'



## Equipment

<b>Type</b>	high-strength steel plates at highly stressed points for the toughest requirements. Complex and stable mountings of equipment and cylinders
<b>Hydraulic cylinders</b>	Liebherr cylinders with special sealing and guide system and, depending on cylinder type, shock absorption
<b>Bearings</b>	sealed, low maintenance



## Complete Machine

<b>Lubrication</b>	Liebherr central lubrication system for upper-carriage and equipment, automatically	
<b>Noise emission</b>		
ISO 6396	L <sub>PA</sub> (inside cab)	= 71 dB(A)
2000/14/EC	L <sub>WA</sub> (surround noise)	= 100 dB(A)



# Dimensions

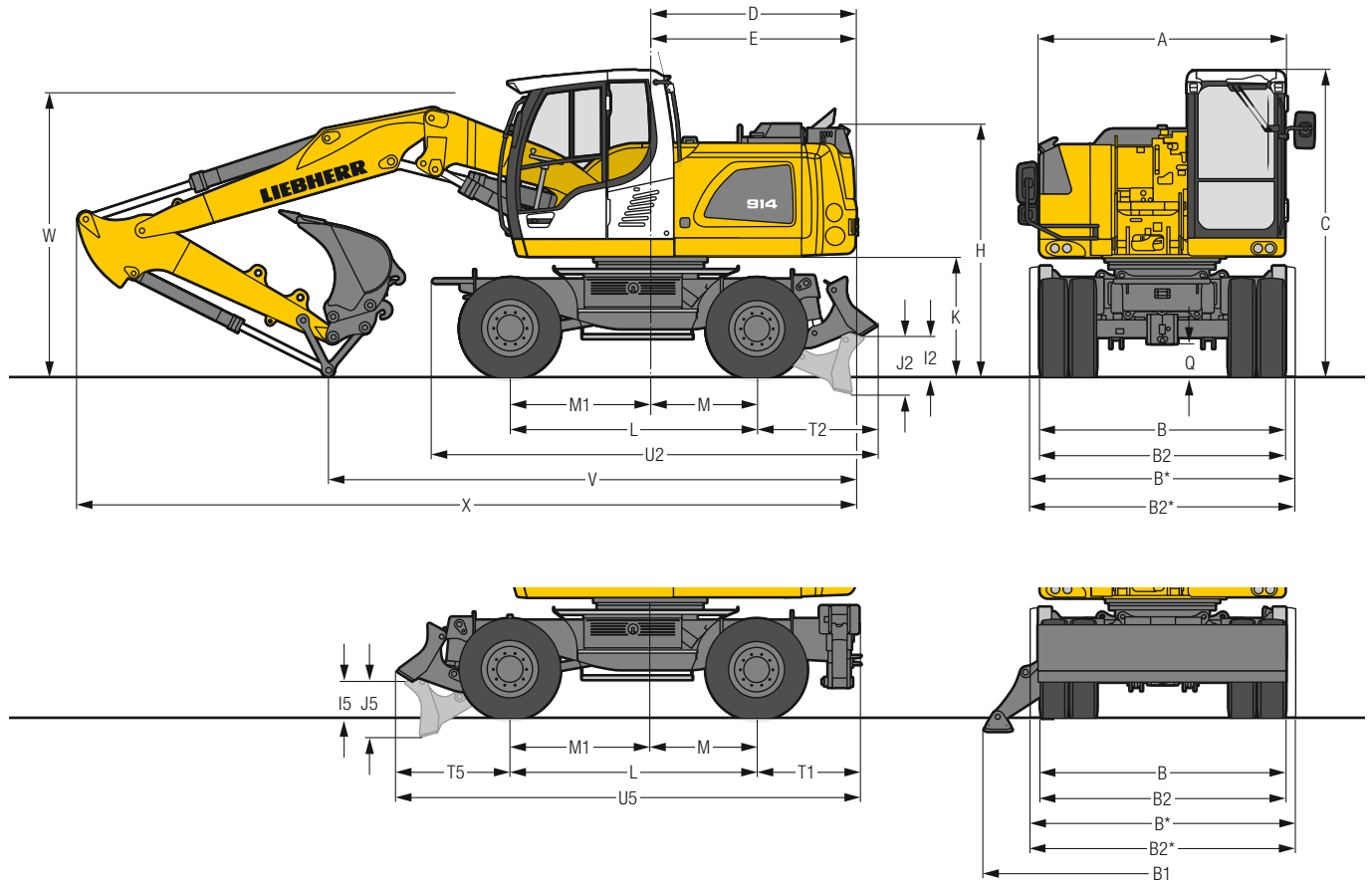

	ft in
<b>A</b>	8' 3"
<b>B</b>	8' 4"
<b>B*</b>	9'
<b>B1</b>	12' 1"
<b>B2</b>	8' 4"
<b>B2*</b>	9'
<b>C</b>	10' 5"
<b>D</b>	6'11"
<b>E</b>	7' 1"
<b>H</b>	8' 7"
<b>I2</b>	1' 5"
<b>I5</b>	1' 3"
<b>J2</b>	2'
<b>J5</b>	1'11"
<b>K</b>	4'
<b>L</b>	8' 4"
<b>M</b>	3' 7"
<b>M1</b>	4' 9"
<b>Q</b>	1' 2"
<b>T1</b>	3' 5"
<b>T2</b>	4'
<b>T5</b>	3' 9"
<b>U2</b>	15'
<b>U5</b>	15' 7"

\* EW-Undercarriage  
E = Tail radius  
Tires 10.00-20

	Stick ft in	Two-piece boom 15'11"		Mono boom 15'1"	
		Rear blade ft in	Rear outriggers + front blade ft in	Rear blade ft in	Rear outriggers + front blade ft in
<b>V</b>	7'5"	18' 6"	18'1"	16'9"	16' 3"
	8'	17' 3"	16'9"	18'1"	17' 7"
<b>W</b>	7'5"	17' 5"	18'6"	19'2" <sup>1)</sup>	18' 8" <sup>1)</sup>
	8'	9' 6"	9'6"	9'6"	9' 6"
<b>X</b>	8'	9' 2"	9'2"	10'8"	10' 8"
	8'8"	10*	10*	10'4" <sup>1)</sup>	10' 4" <sup>1)</sup>
	7'5"	27' 1"	26'7"	26'1"	25' 7"
	8'	27' 1"	26'7"	26'3"	26'11"
	8'8"	26'11"	28'1"	26'3" <sup>1)</sup>	25' 9" <sup>1)</sup>

	Stick ft in	Offset two-piece boom 16'1"		Offset mono boom 14'1"	
		Rear blade ft in	Rear outriggers + front blade ft in	Rear blade ft in	Rear outriggers + front blade ft in
<b>V</b>	7'5"	19'6"	19'	18' 3"	19"
	8'	18'4"	17'11"	19" <sup>1)</sup>	18' 4" <sup>1)</sup>
<b>W</b>	7'5"	10'4"	10' 4"	10'10"	10'10"
	8'	10'2"	10' 2"	10' 4" <sup>1)</sup>	10' 4" <sup>1)</sup>
<b>X</b>	7'5"	27'1"	26' 7"	25' 1"	26' 1"
	8'	27'3"	26' 9"	25' 5" <sup>1)</sup>	24'11" <sup>1)</sup>

Dimensions are with equipment over steering axle  
\* Equipment over digging axle for shorter transport dimensions  
<sup>1)</sup> without backhoe bucket  
W = Max. ground clearance including approx. 6" piping



# Backhoe Bucket

## with Two-Piece Boom 15'11"

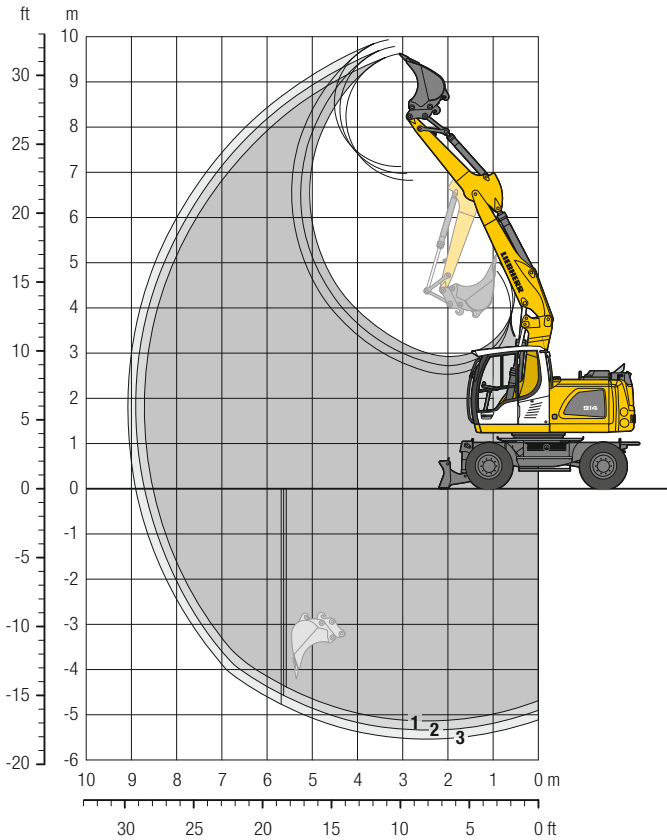

### Digging Envelope

with quick coupler		1	2	3
Stick length	ft in	7' 5"	8'	8'8"
Max. digging depth	ft in	16'11"	17' 7"	18'3"
Max. reach at ground level	ft in	27'11"	28' 7"	29'2"
Max. dumping height	ft in	22' 6"	23'	23'5"
Max. teeth height	ft in	31' 8"	32' 2"	32'8"
Min. equipment radius	ft in	7' 8"	7'10"	8'

### Digging Forces

without quick coupler		1	2	3
Max. digging force (ISO 6015)	lbf	15,467	14,500	13,646
Max. breakout force (ISO 6015)	lbf	19,131	19,131	19,131
	lb	19,180	19,180	19,180

Max. breakout force with ripper bucket

27,899 lbf (27,778 lb)

### Operating Weight

The operating weight includes the basic machine with 8 tires plus intermediate rings, two-piece boom 15'11", stick 8'8" and bucket 33.5"/0.65 yd<sup>3</sup>.

Undercarriage versions	Weight (lb)
A 914 Litronic with rear blade	33,600/32,800*
A 914 Litronic with rear outriggers + front blade	36,300/35,500*
A 914 Litronic with rear + front outriggers	36,900/36,200*
A 914 EW Litronic with rear blade	34,400/33,600*
A 914 EW Litronic with rear outriggers + front blade	36,700/35,900*

\* Operating weight without bucket

### Buckets Machine stability per ISO 10567\* (75% of tipping capacity)

Cutting width in	Capacity ISO 7451 <sup>1)</sup> yd <sup>3</sup>	Weight lb	Stabilizers raised			Rear blade down			Rear outriggers + front blade down			EW Stabilizers raised			EW Rear blade down			EW Rear outriggers + front blade down		
			Stick length (ft in)			Stick length (ft in)			Stick length (ft in)			Stick length (ft in)			Stick length (ft in)			Stick length (ft in)		
			7'5"	8'	8'8"	7'5"	8'	8'8"	7'5"	8'	8'8"	7'5"	8'	8'8"	7'5"	8'	8'8"	7'5"	8'	8'8"
11.8" <sup>2)</sup>	0.22	485	■	■	■	■	■	■	■	■	■	■	■	■	■	■	■	■	■	
15.7" <sup>2)</sup>	0.31	551	■	■	■	■	■	■	■	■	■	■	■	■	■	■	■	■	■	
19.7" <sup>2)</sup>	0.37	551	■	■	■	■	■	■	■	■	■	■	■	■	■	■	■	■	■	
21.7" <sup>2)</sup>	0.38	573	■	■	■	■	■	■	■	■	■	■	■	■	■	■	■	■	■	
25.6" <sup>2)</sup>	0.47	639	■	■	■	■	■	■	■	■	■	■	■	■	■	■	■	■	■	
33.5" <sup>2)</sup>	0.65	750	■	■	■	■	■	■	■	■	■	■	■	■	■	■	■	■	■	
41.3" <sup>2)</sup>	0.85	838	■	■	■	■	■	■	■	■	■	■	■	■	■	■	■	■	■	
49.2" <sup>2)</sup>	1.05	948	■	■	△	■	■	■	■	■	■	■	■	■	■	■	■	■	■	
11.8" <sup>3)</sup>	0.24	463	■	■	■	■	■	■	■	■	■	■	■	■	■	■	■	■	■	
15.7" <sup>3)</sup>	0.34	529	■	■	■	■	■	■	■	■	■	■	■	■	■	■	■	■	■	
19.7" <sup>3)</sup>	0.39	529	■	■	■	■	■	■	■	■	■	■	■	■	■	■	■	■	■	
21.7" <sup>3)</sup>	0.41	551	■	■	■	■	■	■	■	■	■	■	■	■	■	■	■	■	■	
25.6" <sup>3)</sup>	0.51	595	■	■	■	■	■	■	■	■	■	■	■	■	■	■	■	■	■	
33.5" <sup>3)</sup>	0.69	705	■	■	■	■	■	■	■	■	■	■	■	■	■	■	■	■	■	
41.3" <sup>3)</sup>	0.93	816	■	■	■	■	■	■	■	■	■	■	■	■	■	■	■	■	■	
49.2" <sup>3)</sup>	1.14	926	△	△	△	■	■	■	■	■	■	■	■	■	■	■	■	■	■	

\* Indicated loads are based on ISO 10567 and do not exceed 75% of tipping or 87% of hydraulic capacity, max. stick length without quick coupler, lifted 360° on firm with blocked oscillating axle

<sup>1)</sup> comparable with SAE (heaped)

<sup>2)</sup> Bucket with teeth (also available in HD-version) <sup>3)</sup> Bucket with cutting edge (also available in HD-version)

Buckets up to 19.7" cutting width with limited digging depth

Max. material weight ■ = ≤ 3,034 lb/yd<sup>3</sup>, ■ = ≤ 2,528 lb/yd<sup>3</sup>, △ = ≤ 2,023 lb/yd<sup>3</sup>, - = not authorized

# Lift Capacities

## with Two-Piece Boom 15'11"

### Stick 7'5"

ft	Undercarriage stabilized		10 ft		15 ft		20 ft		25 ft		ft in
	rear	front	Blade	Outriggers	Blade	Outriggers	Blade	Outriggers	Blade	Outriggers	
25	—	—	—	—	—	—	—	—	—	—	4,9* 4,9*
	Blade	—	—	—	—	—	—	—	—	—	4,9* 4,9*
20	—	—	—	—	8,2	8,4*	—	—	—	—	4,3* 4,3*
	Blade	—	—	—	8,4*	8,4*	—	—	—	—	4,3* 4,3*
15	—	—	—	—	8,1	10,6*	5,1	8,1	—	—	4,0 4,1*
	Blade	—	—	—	8,9	10,6*	5,6	8,2*	—	—	4,1* 4,1*
10	—	—	14,1	19,1*	7,9	12,3	5,0	8,1	—	—	3,4 4,2*
	Blade	—	15,6	19,1*	8,7	12,4*	5,6	9,7*	—	—	3,9 4,2*
5	—	—	13,8	21,3*	7,8	12,1	4,9	7,9	—	—	3,2 4,6*
	Blade	—	15,3	21,3*	8,6	13,9*	5,4	10,2*	—	—	3,6 4,6*
0	—	—	13,4	22,8*	7,4	12,2	4,5	7,6	—	—	3,3 5,4*
	Blade	—	15,2	22,8*	8,3	14,3*	5,1	10,4*	—	—	3,7 5,4*
-5	—	—	12,7	23,3	6,8	11,8	4,3	7,3	—	—	3,7 6,4
	Blade	—	14,4	23,3*	7,7	14,6*	4,8	9,8*	—	—	4,1 6,9*
-10	—	—	12,1	22,2*	6,4	11,3	—	—	—	—	4,7 6,7*
	Blade	—	13,8	22,2*	7,2	12,0*	—	—	—	—	5,3 6,7*

### Stick 8'

ft	Undercarriage stabilized		10 ft		15 ft		20 ft		25 ft		ft in
	rear	front	Blade	Outriggers	Blade	Outriggers	Blade	Outriggers	Blade	Outriggers	
25	—	—	—	—	5,2*	5,2*	—	—	—	—	4,5* 4,5*
	Blade	—	—	—	5,2*	5,2*	—	—	—	—	4,5* 4,5*
20	—	—	—	—	7,9*	7,9*	4,8*	4,8*	—	—	3,9* 3,9*
	Blade	—	—	—	7,9*	7,9*	4,8*	4,8*	—	—	3,9* 3,9*
15	—	—	—	—	8,1	9,5*	5,1	7,9*	—	—	3,7* 3,7*
	Blade	—	—	—	8,9	9,5*	5,7	7,9*	—	—	3,7* 3,7*
10	—	—	14,1	18,2*	7,9	12,0*	5,1	8,1	—	—	3,3 3,8*
	Blade	—	15,6	18,2*	8,7	12,0*	5,6	9,4*	—	—	3,7 3,8*
5	—	—	13,7	21,2*	7,8	12,0	4,9	7,9	—	—	3,1 4,2*
	Blade	—	15,2	21,2*	8,5	13,7*	5,4	10,1*	3,1	4,8*	3,5 4,2*
0	—	—	13,5	22,5*	7,5	12,1	4,6	7,6	—	—	3,1 4,8*
	Blade	—	15,3	22,5*	8,3	14,2*	5,1	10,3*	—	—	3,5 4,8*
-5	—	—	12,7	23,1	6,9	11,9	4,3	7,3	—	—	3,5 6,0
	Blade	—	14,4	23,1*	7,7	14,4*	4,8	10,0*	—	—	3,9 6,1*
-10	—	—	12,1	23,0*	6,4	11,3	—	—	—	—	4,4 6,6*
	Blade	—	13,8	23,0*	7,2	12,9*	—	—	—	—	4,9 6,6*

### Stick 8'8"

ft	Undercarriage stabilized		10 ft		15 ft		20 ft		25 ft		ft in
	rear	front	Blade	Outriggers	Blade	Outriggers	Blade	Outriggers	Blade	Outriggers	
25	—	—	—	—	5,7*	5,7*	—	—	—	—	4,1* 4,1*
	Blade	—	—	—	5,7*	5,7*	—	—	—	—	4,1* 4,1*
20	—	—	—	—	7,3*	7,3*	5,1	5,3*	—	—	3,6* 3,6*
	Blade	—	—	—	7,3*	7,3*	5,3*	5,3*	—	—	3,6* 3,6*
15	—	—	—	—	8,1	8,6*	5,2	7,6*	—	—	3,4* 3,4*
	Blade	—	—	—	8,6*	8,6*	5,7	7,6*	—	—	3,4* 3,4*
10	—	—	14,1	17,3*	7,9	11,7*	5,1	8,1	3,3	4,6*	3,1 3,5*
	Blade	—	15,6	17,3*	8,6	11,7*	5,7	9,2*	3,7	4,6*	3,5* 3,5*
5	—	—	13,7	21,1*	7,7	12,0	4,9	8,0	3,1	5,4	2,9 3,8*
	Blade	—	15,1	21,1*	8,5	13,5*	5,5	9,9*	3,5	5,9*	3,3 3,8*
0	—	—	13,6	22,3*	7,5	12,0	4,6	7,7	3,0	4,8*	3,0 4,3*
	Blade	—	15,2	22,3*	8,3	14,1*	5,2	10,2*	3,4	4,8*	3,4 4,3*
-5	—	—	12,7	22,9	7,0	11,9	4,3	7,3	—	—	3,3 5,4*
	Blade	—	14,4	23,0*	7,8	14,3*	4,8	10,2*	—	—	3,7 5,4*
-10	—	—	12,1	23,4	6,4	11,3	4,1	6,7*	—	—	4,1 6,5*
	Blade	—	13,8	23,4*	7,2	13,5*	4,6	6,7*	—	—	4,6 6,5*

Height Can be slewed through 360° In longitudinal position of undercarriage Max. reach \* Limited by hydr. capacity

The lift capacities on the load lift hook of the Liebherr quick coupler SWA 33 without working tool are stated in lb x 1,000 and are valid on a firm, level supporting surface with blocked oscillating axle. These capacities can be slewed through 360° with the undercarriage in the transverse position. Capacities in the longitudinal position of the undercarriage (+/- 15°) are specified over the steering axle with the stabilizers raised and over the rigid axle with the stabilizers down. The values apply when the adjusting cylinder is in the optimal position. Indicated loads based on the ISO 10567 standard and do not exceed 75% of tipping or 87% of hydraulic capacity, or are limited by the permissible load of the load lift hook on the quick coupler (max. 11,000 lb). Without the quick coupler, lift capacities will increase by up to 240 lb.



# Lift Capacities

## with Two-Piece Boom 15'11", EW-Undercarriage

### Stick 7'5"

ft	Undercarriage stabilized		10 ft		15 ft		20 ft		25 ft		ft in
	rear	front	rear	front	rear	front	rear	front	rear	front	
25	Blade	—	—	—	—	—	—	—	—	—	4,9* 4,9*
	Outriggers	Blade	—	—	—	—	—	—	—	—	4,9* 4,9*
20	Blade	—	—	—	8,4* 8,4*	—	—	—	—	—	4,3* 4,3*
	Outriggers	Blade	—	—	8,4* 8,4*	—	—	—	—	—	4,3* 4,3*
15	Blade	—	—	—	9,0 10,6*	5,7 8,2*	—	—	—	—	4,1* 4,1*
	Outriggers	Blade	—	—	9,9 10,6*	6,3 8,2*	—	—	—	—	4,1* 4,1*
10	Blade	—	—	15,8 19,1*	8,8 12,4*	5,6 8,3	—	—	—	—	3,9 4,2*
	Outriggers	Blade	—	17,5 19,1*	9,6 12,4*	6,2 9,7*	—	—	—	—	4,2* 4,2*
5	Blade	—	—	15,4 21,3*	8,7 12,3	5,5 8,1	—	—	—	—	3,7 4,6*
	Outriggers	Blade	—	17,1 21,3*	9,5 13,9*	6,1 10,2*	—	—	—	—	4,2 4,6*
0	Blade	—	—	15,4 22,8*	8,4 12,4	5,2 7,8	—	—	—	—	3,8 5,4*
	Outriggers	Blade	—	17,3 22,8*	9,4 14,3*	5,8 10,4*	—	—	—	—	4,2 5,4*
-5	Blade	—	—	14,6 23,3*	7,8 12,1	4,9 7,5	—	—	—	—	4,2 6,5
	Outriggers	Blade	—	16,6 23,3*	8,7 14,6*	5,5 9,8*	—	—	—	—	4,7 6,9*
-10	Blade	—	—	13,9 22,2*	7,4 11,6	—	—	—	—	—	5,4 6,7*
	Outriggers	Blade	—	16,0 22,2*	8,3 12,0*	—	—	—	—	—	6,1 6,7*

### Stick 8'

ft	Undercarriage stabilized		10 ft		15 ft		20 ft		25 ft		ft in
	rear	front	rear	front	rear	front	rear	front	rear	front	
25	Blade	—	—	—	—	—	—	—	—	—	4,5* 4,5*
	Outriggers	Blade	—	—	—	—	—	—	—	—	4,5* 4,5*
20	Blade	—	—	—	—	—	—	—	—	—	4,5* 4,5*
	Outriggers	Blade	—	—	—	—	—	—	—	—	4,5* 4,5*
15	Blade	—	—	—	—	—	—	—	—	—	3,9* 3,9*
	Outriggers	Blade	—	—	—	—	—	—	—	—	3,9* 3,9*
10	Blade	—	—	—	—	—	—	—	—	—	3,7* 3,7*
	Outriggers	Blade	—	—	—	—	—	—	—	—	3,7* 3,7*
5	Blade	—	—	—	—	—	—	—	—	—	3,7 3,8*
	Outriggers	Blade	—	—	—	—	—	—	—	—	3,8* 3,8*
0	Blade	—	—	—	—	—	—	—	—	—	3,5 4,2*
	Outriggers	Blade	—	—	—	—	—	—	—	—	4,0 4,2*
-5	Blade	—	—	—	—	—	—	—	—	—	4,0 4,8*
	Outriggers	Blade	—	—	—	—	—	—	—	—	4,2* 4,2*
-10	Blade	—	—	—	—	—	—	—	—	—	3,6 4,8*
	Outriggers	Blade	—	—	—	—	—	—	—	—	4,0 4,2*

### Stick 8'8"

ft	Undercarriage stabilized		10 ft		15 ft		20 ft		25 ft		ft in
	rear	front	rear	front	rear	front	rear	front	rear	front	
25	Blade	—	—	—	—	—	—	—	—	—	4,1* 4,1*
	Outriggers	Blade	—	—	—	—	—	—	—	—	4,1* 4,1*
20	Blade	—	—	—	—	—	—	—	—	—	3,6* 3,6*
	Outriggers	Blade	—	—	—	—	—	—	—	—	3,6* 3,6*
15	Blade	—	—	—	—	—	—	—	—	—	3,4* 3,4*
	Outriggers	Blade	—	—	—	—	—	—	—	—	3,4* 3,4*
10	Blade	—	—	—	—	—	—	—	—	—	3,5* 3,5*
	Outriggers	Blade	—	—	—	—	—	—	—	—	3,5* 3,5*
5	Blade	—	—	—	—	—	—	—	—	—	3,4 3,8*
	Outriggers	Blade	—	—	—	—	—	—	—	—	3,8* 3,8*
0	Blade	—	—	—	—	—	—	—	—	—	3,4 4,3*
	Outriggers	Blade	—	—	—	—	—	—	—	—	3,9 4,3*
-5	Blade	—	—	—	—	—	—	—	—	—	4,3* 4,3*
	Outriggers	Blade	—	—	—	—	—	—	—	—	4,3* 4,3*
-10	Blade	—	—	—	—	—	—	—	—	—	4,7 6,5*
	Outriggers	Blade	—	—	—	—	—	—	—	—	5,3 6,5*

Height Can be slewed through 360° In longitudinal position of undercarriage Max. reach \* Limited by hydr. capacity

The lift capacities on the load lift hook of the Liebherr quick coupler SWA 33 without working tool are stated in lb x 1,000 and are valid on a firm, level supporting surface with blocked oscillating axle. These capacities can be slewed through 360° with the undercarriage in the transverse position. Capacities in the longitudinal position of the undercarriage (+/- 15°) are specified over the steering axle with the stabilizers raised and over the rigid axle with the stabilizers down. The values apply when the adjusting cylinder is in the optimal position. Indicated loads based on the ISO 10567 standard and do not exceed 75% of tipping or 87% of hydraulic capacity, or are limited by the permissible load of the load lift hook on the quick coupler (max. 11,000 lb). Without the quick coupler, lift capacities will increase by up to 240 lb.

# Backhoe Bucket with Mono Boom 15'1"

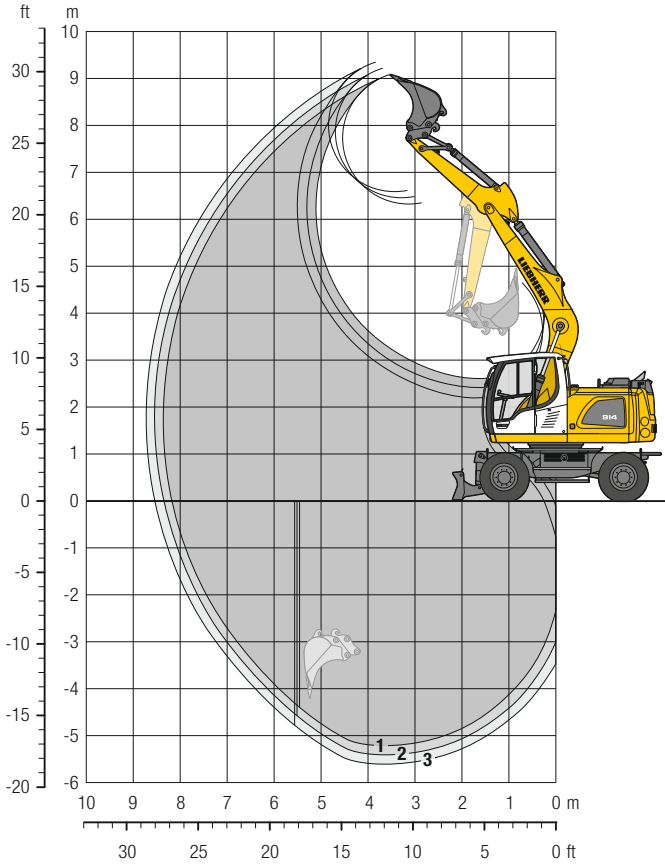

## Digging Envelope

with quick coupler		1	2	3
Stick length	ft in	7' 5"	8'	8' 8"
Max. digging depth	ft in	17' 1"	17'9"	18' 4"
Max. reach at ground level	ft in	26' 9"	27'5"	28' 1"
Max. dumping height	ft in	20'10"	21'4"	21'10"
Max. teeth height	ft in	29'10"	30'4"	30'10"
Min. equipment radius	ft in	6' 9"	6'9"	6'10"

## Digging Forces

without quick coupler		1	2	3
Max. digging force (ISO 6015)	lbf	15,467	14,500	13,646
Max. breakout force (ISO 6015)	lbf	19,131	19,131	19,131
	lb	19,180	19,180	19,180

Max. breakout force with ripper bucket 27,899 lbf (27,778 lb)

## Operating Weight

The operating weight includes the basic machine with 8 tires plus intermediate rings, mono boom 15'1", stick 8" and bucket 33.5"/0.65 yd<sup>3</sup>.

Undercarriage versions	Weight (lb)
A 914 Litronic with rear blade	32,900/32,100*
A 914 Litronic with rear outriggers + front blade	35,500/34,700*

\* Operating weight without bucket

## Buckets Machine stability per ISO 10567\* (75% of tipping capacity)

Cutting width in	Capacity ISO 7451 <sup>1)</sup> yd <sup>3</sup>	Weight lb	Stabilizers raised			Rear blade down			Rear outriggers + front blade down		
			Stick length (ft in)			Stick length (ft in)			Stick length (ft in)		
			7'5"	8'	8'8"	7'5"	8'	8'8"	7'5"	8'	8'8"
11.8" <sup>2)</sup>	0.22	485	■	■	■	■	■	■	■	■	
15.7" <sup>2)</sup>	0.31	551	■	■	■	■	■	■	■	■	
19.7" <sup>2)</sup>	0.37	551	■	■	■	■	■	■	■	■	
21.7" <sup>2)</sup>	0.38	573	■	■	■	■	■	■	■	■	
25.6" <sup>2)</sup>	0.47	639	■	■	■	■	■	■	■	■	
33.5" <sup>2)</sup>	0.65	750	■	■	■	■	■	■	■	■	
41.3" <sup>2)</sup>	0.85	838	■	■	■	■	■	■	■	■	
49.2" <sup>2)</sup>	1.05	948	■	■	■	■	■	■	■	■	
11.8" <sup>3)</sup>	0.24	463	■	■	■	■	■	■	■	■	
15.7" <sup>3)</sup>	0.34	529	■	■	■	■	■	■	■	■	
19.7" <sup>3)</sup>	0.39	529	■	■	■	■	■	■	■	■	
21.7" <sup>3)</sup>	0.41	551	■	■	■	■	■	■	■	■	
25.6" <sup>3)</sup>	0.51	595	■	■	■	■	■	■	■	■	
33.5" <sup>3)</sup>	0.69	705	■	■	■	■	■	■	■	■	
41.3" <sup>3)</sup>	0.93	816	■	■	■	■	■	■	■	■	
49.2" <sup>3)</sup>	1.14	926	■	■	△	■	■	■	■	■	

\* Indicated loads are based on ISO 10567 and do not exceed 75% of tipping or 87% of hydraulic capacity, max. stick length without quick coupler, lifted 360° on firm with blocked oscillating axle

<sup>1)</sup> comparable with SAE (heaped)

<sup>2)</sup> Bucket with teeth (also available in HD version) <sup>3)</sup> Bucket with cutting edge (also available in HD version)

Buckets up to 19.7" cutting width with limited digging depth

Max. material weight ■ = ≤ 3,034 lb/yd<sup>3</sup>, ■ = ≤ 2,528 lb/yd<sup>3</sup>, △ = ≤ 2,023 lb/yd<sup>3</sup>, - = not authorized



# Lift Capacities

## with Mono Boom 15'1"

### Stick 7'5"

ft	Undercarriage stabilized		10 ft		15 ft		20 ft		25 ft		ft in
	rear	front									
25	Blade	—									
	Outriggers	Blade									
20	Blade	—			7,5*	7,5*				4,2*	4,2*
	Outriggers	Blade			7,5*	7,5*				4,2*	4,2*
15	Blade	—			7,9	8,4*	5,0	6,4*		4,1*	4,1*
	Outriggers	Blade			8,4*	8,4*	5,5	6,4*		4,1*	4,1*
10	Blade	—	13,5	15,3*	7,3	10,6*	4,8	7,8		3,8	4,3*
	Outriggers	Blade	15,3*	15,3*	10,6*	10,6*	8,4	8,8*		4,3*	4,3*
5	Blade	—	11,8	18,1*	6,7	11,6	4,5	7,6		3,6	4,8*
	Outriggers	Blade	18,1*	18,1*	12,5	12,9*	8,1	9,8*		4,8*	4,8*
0	Blade	—	11,2	16,8*	6,3	11,2	4,3	7,3		3,6	5,8*
	Outriggers	Blade	16,8*	16,8*	7,1	14,2*	4,8	10,3*		4,1	5,8*
-5	Blade	—	11,2	21,2*	6,2	11,0	4,2	7,2		4,1	7,0
	Outriggers	Blade	21,2*	21,2*	11,8	14,0*	7,8	9,9*		4,6	8,2*
-10	Blade	—	11,4	17,3*	6,3	11,1				5,5	9,6
	Outriggers	Blade	17,3*	17,3*	11,6*	11,6*				6,2	10,1*

### Stick 8'

ft	Undercarriage stabilized		10 ft		15 ft		20 ft		25 ft		ft in
	rear	front									
25	Blade	—									4,5*
	Outriggers	Blade									4,5*
20	Blade	—								7,1*	7,1*
	Outriggers	Blade								7,1*	7,1*
15	Blade	—								7,9	8,0*
	Outriggers	Blade								8,0*	8,0*
10	Blade	—	13,7	14,2*	7,4	10,1*	4,8	7,8		3,7	3,9*
	Outriggers	Blade	14,2*	14,2*	10,1*	10,1*	8,4	8,5*		3,9*	3,9*
5	Blade	—	11,9	20,9*	6,7	11,6	4,5	7,5		3,4	4,3*
	Outriggers	Blade	20,9*	20,9*	12,5	12,6*	8,1	9,6*		4,3*	4,3*
0	Blade	—	11,1	16,9*	6,3	11,1	4,2	7,3		3,5	5,2*
	Outriggers	Blade	16,9*	16,9*	7,1	14,1*	4,8	10,2*		3,9	5,2*
-5	Blade	—	11,0	21,6*	6,1	10,9	4,2	7,2		3,9	6,6
	Outriggers	Blade	21,6*	21,6*	11,7	14,0*	7,7	10,0*		4,3	7,1*
-10	Blade	—	11,2	18,0*	6,2	11,0				5,1	8,8
	Outriggers	Blade	18,0*	18,0*	11,8	12,0*				5,7	9,8*

### Stick 8'8"

ft	Undercarriage stabilized		10 ft		15 ft		20 ft		25 ft		ft in
	rear	front									
25	Blade	—									4,1*
	Outriggers	Blade									4,1*
20	Blade	—									4,1*
	Outriggers	Blade									4,1*
15	Blade	—			6,6*	6,6*				3,5*	3,5*
	Outriggers	Blade			6,6*	6,6*				3,5*	3,5*
10	Blade	—					5,0	6,6*		3,4*	3,4*
	Outriggers	Blade					6,6*	6,6*		3,4*	3,4*
5	Blade	—	13,2*	13,2*	7,4	9,7*	4,8	7,9		3,5	3,6*
	Outriggers	Blade	13,2*	13,2*	8,3	9,7*	5,3	8,2*		3,6*	3,6*
0	Blade	—	12,0	20,1*	6,8	11,7	4,5	7,5		3,3	3,9*
	Outriggers	Blade	20,1*	20,1*	12,2*	12,2*	8,1	9,3*		3,9*	3,9*
-5	Blade	—	11,1	17,1*	6,3	11,1	4,2	7,3		3,3	4,6*
	Outriggers	Blade	17,1*	17,1*	7,1	13,9*	4,7	10,1*		3,7	4,6*
-10	Blade	—	10,9	20,9*	6,1	10,9	4,1	7,1		3,6	6,2*
	Outriggers	Blade	20,9*	20,9*	11,7	14,0*	7,7	10,1*		4,1	6,2*

Height Can be slewed through 360° In longitudinal position of undercarriage Max. reach \* Limited by hydr. capacity

The lift capacities on the load lift hook of the Liebherr quick coupler SWA 33 without working tool are stated in lb x 1,000 and are valid on a firm, level supporting surface with blocked oscillating axle. These capacities can be slewed through 360° with the undercarriage in the transverse position. Capacities in the longitudinal position of the undercarriage (+/- 15°) are specified over the steering axle with the stabilizers raised and over the rigid axle with the stabilizers down. Indicated loads based on the ISO 10567 standard and do not exceed 75% of tipping or 87% of hydraulic capacity, or are limited by the permissible load of the load lift hook on the quick coupler (max. 11,000 lb). Without the quick coupler, lift capacities will increase by up to 240 lb.

# Backhoe Bucket

## with Offset Two-Piece Boom 16'1"

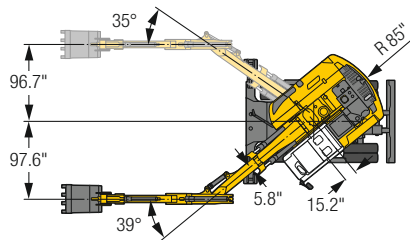
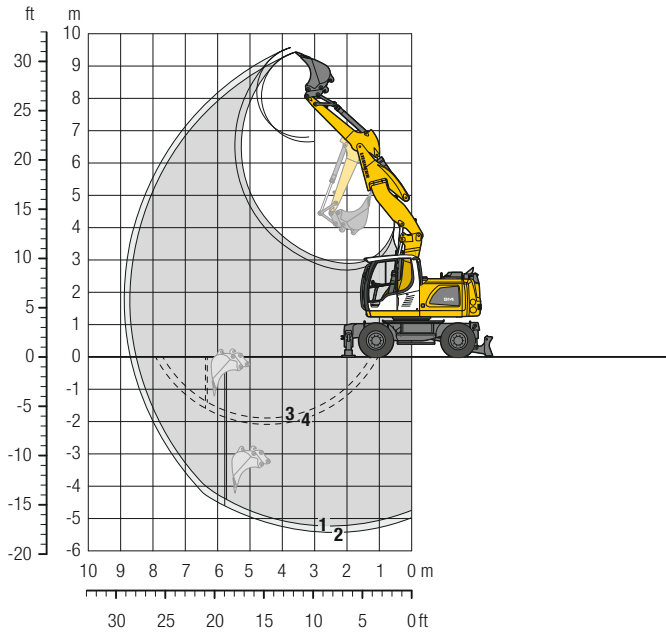

### Digging Envelope

with quick coupler		1	2
Stick length	ft in	7' 5"	8'
Max. digging depth	ft in	17' 1"	17'9"
Max. reach at ground level	ft in	27'11"	28'7"
Max. dumping height	ft in	22'	22'4"
Max. teeth height	ft in	31'	31'6"
Min. equipment radius	ft in	7' 7"	7'8"

1 with stick 7'5"

2 with stick 8'

with set straight boom

3 with stick 7'5"

4 with stick 8'

at max. equipment offset  
with vertical ditch walls

### Digging Forces

without quick coupler		1	2
Max. digging force (ISO 6015)	lbf	15,467	14,500
	lb	15,432	14,551
Max. breakout force (ISO 6015)	lbf	19,131	19,131
	lb	19,180	19,180
Max. breakout force with ripper bucket		27,899 lbf (27,778 lb)	

### Operating Weight

The operating weight includes the basic machine with 8 tires plus intermediate rings, offset two-piece boom 16'1", stick 8' and bucket 33.5"/0.65 yd<sup>3</sup>.

Undercarriage versions	Weight (lb)
A 914 Litronic with rear blade	34,900/34,100*
A 914 Litronic with rear outriggers + front blade	37,500/36,700*
A 914 EW Litronic with rear blade	35,500/34,700*
A 914 EW Litronic with rear outriggers + front blade	37,900/37,100*

\* Operating weight without bucket

### Buckets Machine stability per ISO 10567\* (75% of tipping capacity)

Cutting width in	Capacity ISO 7451 <sup>1)</sup> yd <sup>3</sup>	Weight lb	Stabilizers raised		Rear blade down		Rear outriggers + front blade down		EW Stabilizers raised		EW Rear blade down		EW Rear outriggers + front blade down	
			Stick length (ft in)		Stick length (ft in)		Stick length (ft in)		Stick length (ft in)		Stick length (ft in)		Stick length (ft in)	
			7'5"	8'	7'5"	8'	7'5"	8'	7'5"	8'	7'5"	8'	7'5"	8'
21.7" <sup>2)</sup>	0.38	573	■	■	■	■	■	■	■	■	■	■	■	■
25.6" <sup>2)</sup>	0.47	639	■	■	■	■	■	■	■	■	■	■	■	■
33.5" <sup>2)</sup>	0.65	750	■	■	■	■	■	■	■	■	■	■	■	■
41.3" <sup>2)</sup>	0.85	838	■	■	■	■	■	■	■	■	■	■	■	■
49.2" <sup>2)</sup>	1.05	948	△	△	■	■	■	■	■	■	■	■	■	■
11.8" <sup>3)</sup>	0.24	463	■	■	■	■	■	■	■	■	■	■	■	■
15.7" <sup>3)</sup>	0.34	529	■	■	■	■	■	■	■	■	■	■	■	■
19.7" <sup>3)</sup>	0.39	529	■	■	■	■	■	■	■	■	■	■	■	■
21.7" <sup>3)</sup>	0.41	551	■	■	■	■	■	■	■	■	■	■	■	■
25.6" <sup>3)</sup>	0.51	595	■	■	■	■	■	■	■	■	■	■	■	■
33.5" <sup>3)</sup>	0.69	705	■	■	■	■	■	■	■	■	■	■	■	■
41.3" <sup>3)</sup>	0.93	816	■	■	■	■	■	■	■	■	■	■	■	■
49.2" <sup>3)</sup>	1.14	926	△	—	△	△	■	■	■	△	■	■	■	■

\* Indicated loads are based on ISO 10567 and do not exceed 75% of tipping or 87% of hydraulic capacity, max. stick length without quick coupler, lifted 360° on firm with blocked oscillating axle

<sup>1)</sup> comparable with SAE (heaped)

<sup>2)</sup> Bucket with teeth (also available in HD version) <sup>3)</sup> Bucket with cutting edge (also available in HD version)

Buckets up to 19.7" cutting width with limited digging depth

Max. material weight ■ = ≤ 3,034 lb/yd<sup>3</sup>, ■ = ≤ 2,528 lb/yd<sup>3</sup>, △ = ≤ 2,023 lb/yd<sup>3</sup>, — = not authorized



# Lift Capacities

## with Offset Two-Piece Boom 16'1"

### Stick 7'5"

ft	Undercarriage stabilized		10 ft		15 ft		20 ft		25 ft		ft in	
	rear	front										
25	Blade	—									4,7*	4,7*
	Outriggers	Blade									4,7*	4,7*
20	Blade	—			8,2	8,3*					4,1*	4,1*
	Outriggers	Blade			8,3*	8,3*					4,1*	4,1*
15	Blade	—			8,0	9,9*	4,9	7,9			3,7	4,0*
	Outriggers	Blade			8,8	9,9*	5,4	8,0*			4,0*	4,0*
10	Blade	—	13,8	18,0*	7,8	11,6*	4,8	7,9			3,1	4,2*
	Outriggers	Blade	15,2	18,0*	8,5	11,6*	5,4	9,0*			3,6	4,2*
5	Blade	—	13,4	20,2*	7,6	11,7	4,6	7,7			2,9	4,6*
	Outriggers	Blade	14,8	20,2*	8,4	13,1*	5,1	9,6*			3,3	4,6*
0	Blade	—	13,2	21,6	7,3	11,8	4,2	7,3			2,9	5,3
	Outriggers	Blade	15,0	21,6*	8,1	13,4*	4,7	9,7*			3,3	5,5*
-5	Blade	—	12,2	22,2*	6,4	11,4	3,8	6,9			3,2	6,0
	Outriggers	Blade	14,0	22,2*	7,2	13,8*	4,3	9,3*			3,7	7,2*
-10	Blade	—	11,3	21,6*	5,8	10,8					4,2	6,8*
	Outriggers	Blade	13,0	21,6*	6,6	11,6*					4,8	6,8*

### Stick 8'

ft	Undercarriage stabilized		10 ft		15 ft		20 ft		25 ft		ft in	
	rear	front										
25	Blade	—			4,7*	4,7*					4,3*	4,3*
	Outriggers	Blade			4,7*	4,7*					4,3*	4,3*
20	Blade	—			7,8*	7,8*	4,4*	4,4*			3,8*	3,8*
	Outriggers	Blade			7,8*	7,8*	4,4*	4,4*			3,7*	3,7*
15	Blade	—			8,0	9,6*	5,0	7,8*			3,5	3,7*
	Outriggers	Blade			8,8	9,6*	5,5	7,8*			3,7*	3,7*
10	Blade	—	13,8	17,1*	7,7	11,3*	4,9	7,9			3,0	3,8*
	Outriggers	Blade	15,2	17,1*	8,5	11,3*	5,4	8,8*			3,4	3,8*
5	Blade	—	13,3*	20,1*	7,6	11,6	4,7	7,7	2,8	4,4*	2,7	4,1*
	Outriggers	Blade	14,7	20,1*	8,3	12,9*	5,2	9,4*	3,2	4,4*	3,1	4,1*
0	Blade	—	13,4	21,4*	7,3	11,7	4,2	7,4			2,7	4,9*
	Outriggers	Blade	14,8	21,4*	8,2	13,3*	4,8	9,6*			3,2	4,9*
-5	Blade	—	12,2	22,0	6,5	11,6	3,8	6,9			3,0	5,7
	Outriggers	Blade	14,0	22,0*	7,3	13,7*	4,3	9,5*			3,5	6,3*
-10	Blade	—	11,3	22,2*	5,8	10,8					3,9	6,7*
	Outriggers	Blade	13,0	22,2*	6,6	12,4*					4,5	6,7*

 **Height**  **Can be slewed through 360°**  **In longitudinal position of undercarriage**  **Max. reach** \* Limited by hydr. capacity

The lift capacities on the load lift hook of the Liebherr quick coupler SWA 33 without working tool are stated in lb x 1,000 and are valid on a firm, level supporting surface with blocked oscillating axle. These capacities can be slewed through 360° with the undercarriage in the transverse position. Capacities in the longitudinal position of the undercarriage (+/- 15°) are specified over the steering axle with the stabilizers raised and over the rigid axle with the stabilizers down. The values apply when the adjusting cylinder is in the optimal position. Indicated loads based on the ISO 10567 standard and do not exceed 75% of tipping or 87% of hydraulic capacity, or are limited by the permissible load of the load lift hook on the quick coupler (max. 11,000 lb). Without the quick coupler, lift capacities will increase by up to 240 lb.

# Lift Capacities

## with Offset Two-Piece Boom 16'1", EW-Undercarriage

**Stick 7'5"**

ft	Undercarriage stabilized		10 ft		15 ft		20 ft		25 ft		ft in	
	rear	front										
25	Blade	—	—	—	—	—	—	—	—	—	4,7*	4,7*
	Outriggers	Blade	—	—	—	—	—	—	—	—	4,7*	4,7*
20	Blade	—	—	—	8,3*	8,3*	—	—	—	—	4,1*	4,1*
	Outriggers	Blade	—	—	8,3*	8,3*	—	—	—	—	4,1*	4,1*
15	Blade	—	—	—	8,9	9,9*	5,5	8,0*	—	—	4,0*	4,0*
	Outriggers	Blade	—	—	9,7	9,9*	6,1	8,0*	—	—	4,0*	4,0*
10	Blade	—	15,4	18,0*	8,6	11,6*	5,5	8,1	—	—	3,6	4,2*
	Outriggers	Blade	17,0	18,0*	9,4	11,6*	6,1	9,0*	—	—	4,1	4,2*
5	Blade	—	14,9	20,2*	8,5	11,9	5,2	7,9	—	—	3,4	4,6*
	Outriggers	Blade	16,5	20,2*	9,2	13,1*	5,8	9,6*	—	—	3,8	4,6*
0	Blade	—	15,1	21,6*	8,2	12,0	4,8	7,5	—	—	3,4	5,5*
	Outriggers	Blade	16,7	21,6*	9,2	13,4*	5,4	9,7*	—	—	3,9	5,5*
-5	Blade	—	14,2	22,2*	7,3	11,7	4,4	7,1	—	—	3,8	6,1
	Outriggers	Blade	16,2	22,2*	8,3	13,8*	5,0	9,3*	—	—	4,3	7,2*
-10	Blade	—	13,1	21,6*	6,7	11,1	—	—	—	—	4,9	6,8*
	Outriggers	Blade	15,2	21,6*	7,7	11,6*	—	—	—	—	5,6	6,8*

**Stick 8"**

ft	Undercarriage stabilized		10 ft		15 ft		20 ft		25 ft		ft in	
	rear	front										
25	Blade	—	—	—	4,7*	4,7*	—	—	—	—	4,3*	4,3*
	Outriggers	Blade	—	—	4,7*	4,7*	—	—	—	—	4,3*	4,3*
20	Blade	—	—	—	7,8*	7,8*	4,4*	4,4*	—	—	3,8*	3,8*
	Outriggers	Blade	—	—	7,8*	7,8*	4,4*	4,4*	—	—	3,8*	3,8*
15	Blade	—	—	—	8,9	9,6*	5,6	7,8*	—	—	3,7*	3,7*
	Outriggers	Blade	—	—	9,6*	9,6*	6,2	7,8*	—	—	3,7*	3,7*
10	Blade	—	15,4	17,1*	8,6	11,3*	5,5	8,0	—	—	3,5	3,8*
	Outriggers	Blade	17,0	17,1*	9,4	11,3*	6,1	8,8*	—	—	3,8*	3,8*
5	Blade	—	14,9	20,1*	8,4	11,8	5,3	7,9	3,2	4,4*	3,2	4,1*
	Outriggers	Blade	16,4	20,1*	9,2	12,9*	5,9	9,4*	3,7	4,4*	3,7	4,1*
0	Blade	—	15,0	21,4*	8,3	11,9	4,9	7,5	—	—	3,2	4,9*
	Outriggers	Blade	16,6	21,4*	9,3	13,3*	5,5	9,6*	—	—	3,7	4,9*
-5	Blade	—	14,2	22,0*	7,4	11,8	4,4	7,1	—	—	4,9	5,8
	Outriggers	Blade	16,2	22,0*	8,4	13,7*	5,0	9,5*	—	—	4,1	6,3*
-10	Blade	—	13,2	22,2*	6,7	11,1	—	—	—	—	4,5	6,7*
	Outriggers	Blade	15,2	22,2*	7,7	12,4*	—	—	—	—	5,2	6,7*

**Height** **Can be slewed through 360°** **In longitudinal position of undercarriage** **Max. reach** \* Limited by hydr. capacity

The lift capacities on the load lift hook of the Liebherr quick coupler SWA 33 without working tool are stated in lb x 1,000 and are valid on a firm, level supporting surface with blocked oscillating axle. These capacities can be slewed through 360° with the undercarriage in the transverse position. Capacities in the longitudinal position of the undercarriage (+/- 15°) are specified over the steering axle with the stabilizers raised and over the rigid axle with the stabilizers down. The values apply when the adjusting cylinder is in the optimal position. Indicated loads based on the ISO 10567 standard and do not exceed 75% of tipping or 87% of hydraulic capacity, or are limited by the permissible load of the load lift hook on the quick coupler (max. 11,000 lb). Without the quick coupler, lift capacities will increase by up to 240 lb.



# Backhoe Bucket with Offset Mono Boom 14'1"

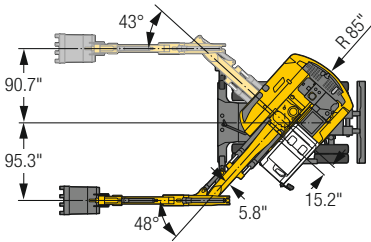
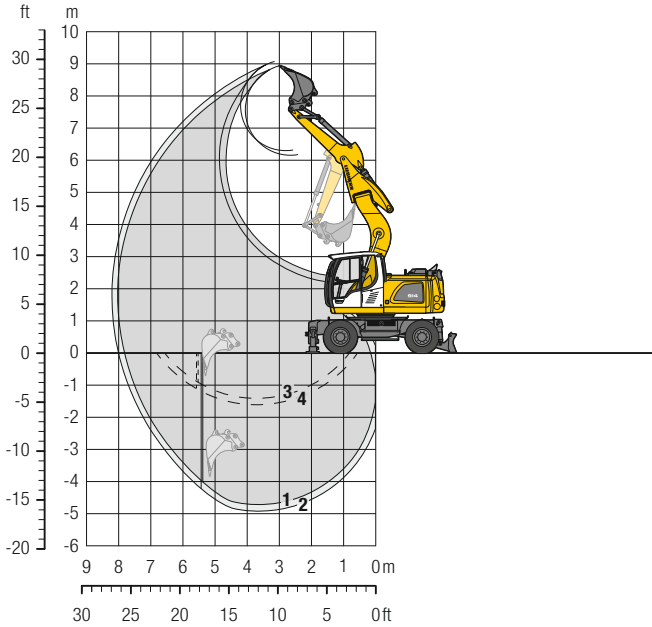

## Digging Envelope

with quick coupler		1	2
Stick length	ft in	7'5"	8'
Max. digging depth	ft in	15'7"	16' 3"
Max. reach at ground level	ft in	25'7"	26' 3"
Max. dumping height	ft in	20'4"	20'10"
Max. teeth height	ft in	29'4"	29'10"
Min. equipment radius	ft in	5'7"	5' 8"

- 1 with stick 7'5"
- 2 with stick 8'  
with set straight boom
- 3 with stick 7'5"
- 4 with stick 8'  
at max. equipment offset  
with vertical ditch walls

## Digging Forces

without quick coupler		1	2
Max. digging force (ISO 6015)	lbf	15,467	14,500
	lb	15,432	14,551
Max. breakout force (ISO 6015)	lbf	19,131	19,131
	lb	19,180	19,180

Max. breakout force with ripper bucket 27,899 lbf (27,778 lb)

## Operating Weight

The operating weight includes the basic machine with 8 tires plus intermediate rings, offset mono boom 14'1", stick 8" and bucket 33.5"/0.65 yd<sup>3</sup>.

Undercarriage versions	Weight (lb)
A 914 Litronic with rear blade	33,500/32,700*
A 914 Litronic with rear outriggers + front blade	36,200/35,400*
A 914 EW Litronic with rear blade	34,200/33,400*
A 914 EW Litronic with rear outriggers + front blade	36,400/35,600*

\* Operating weight without bucket

## Buckets Machine stability per ISO 10567\* (75% of tipping capacity)

Cutting width in	Capacity ISO 7451 <sup>1)</sup> yd <sup>3</sup>	Weight lb	Stabilizers raised		Rear blade down		Rear outriggers + front blade down		EW Stabilizers raised		EW Rear blade down		EW Rear outriggers + front blade down	
			Stick length (ft in)		Stick length (ft in)		Stick length (ft in)		Stick length (ft in)		Stick length (ft in)		Stick length (ft in)	
			7'5"	8'	7'5"	8'	7'5"	8'	7'5"	8'	7'5"	8'	7'5"	8'
21.7 <sup>2)</sup>	0.38	573	■	■	■	■	■	■	■	■	■	■	■	■
25.6 <sup>2)</sup>	0.47	639	■	■	■	■	■	■	■	■	■	■	■	■
33.5 <sup>2)</sup>	0.65	750	■	■	■	■	■	■	■	■	■	■	■	■
41.3 <sup>2)</sup>	0.85	838	■	■	■	■	■	■	■	■	■	■	■	■
49.2 <sup>2)</sup>	1.05	948	■	■	■	■	■	■	■	■	■	■	■	■
11.8 <sup>3)</sup>	0.24	463	■	■	■	■	■	■	■	■	■	■	■	■
15.7 <sup>3)</sup>	0.34	529	■	■	■	■	■	■	■	■	■	■	■	■
19.7 <sup>3)</sup>	0.39	529	■	■	■	■	■	■	■	■	■	■	■	■
21.7 <sup>3)</sup>	0.41	551	■	■	■	■	■	■	■	■	■	■	■	■
25.6 <sup>3)</sup>	0.51	595	■	■	■	■	■	■	■	■	■	■	■	■
33.5 <sup>3)</sup>	0.69	705	■	■	■	■	■	■	■	■	■	■	■	■
41.3 <sup>3)</sup>	0.93	816	■	■	■	■	■	■	■	■	■	■	■	■
49.2 <sup>3)</sup>	1.14	926	■	■	■	■	■	■	■	■	■	■	■	■

\* Indicated loads are based on ISO 10567 and do not exceed 75% of tipping or 87% of hydraulic capacity, max. stick length without quick coupler, lifted 360° on firm with blocked oscillating axle  
<sup>1)</sup> comparable with SAE (heaped)

<sup>2)</sup> Bucket with teeth (also available in HD version)    <sup>3)</sup> Bucket with cutting edge (also available in HD version)

Buckets up to 19.7" cutting width with limited digging depth

Max. material weight ■ = ≤ 3,034 lb/yd<sup>3</sup>, ■ = ≤ 2,528 lb/yd<sup>3</sup>, △ = ≤ 2,023 lb/yd<sup>3</sup>, - = not authorized

# Lift Capacities

## with Offset Mono Boom 14'11"

### Stick 7'5"

ft	Undercarriage stabilized		10 ft		15 ft		20 ft		25 ft		ft in
	rear	front									
25	Blade	—									
	Outriggers	Blade									
20	Blade	—			6,2*	6,2*				4,1*	4,1*
	Outriggers	Blade			6,2*	6,2*				4,1*	4,1*
15	Blade	—			7,9	9,3*	4,1*	4,1*		4,0*	4,0*
	Outriggers	Blade			9,3*	9,3*	4,1*	4,1*		4,0*	4,0*
10	Blade	—	13,7	15,5*	7,3	11,1*	4,6	7,7		4,0	4,2*
	Outriggers	Blade	15,5*	15,5*	11,1*	11,1*	7,9*	7,9*		4,2*	4,2*
5	Blade	—	11,7	21,3*	6,6	11,5	4,3	7,4		3,7	4,8*
	Outriggers	Blade	13,3	21,3*	7,4	13,1*	4,9	9,9*		4,2	4,8*
0	Blade	—	10,8	21,6	6,1	11,0	4,1	7,2		3,7	5,9*
	Outriggers	Blade	12,4	21,7*	6,9	14,1*	4,6	10,2*		4,2	5,9*
-5	Blade	—	10,7	20,0*	5,9	10,8				4,3	7,5
	Outriggers	Blade	12,3	20,0*	6,8	13,2*				4,8	8,7*
-10	Blade	—	11,0	14,7*						6,1	9,7*
	Outriggers	Blade	14,7*	14,7*						9,7*	9,7*

### Stick 8'

ft	Undercarriage stabilized		10 ft		15 ft		20 ft		25 ft		ft in
	rear	front									
25	Blade	—									4,6*
	Outriggers	Blade									4,6*
20	Blade	—			6,3*	6,3*					3,8*
	Outriggers	Blade			6,3*	6,3*					3,8*
15	Blade	—			7,9	8,7*	4,9	4,9*			3,6*
	Outriggers	Blade			8,7*	8,7*	4,9*	4,9*			3,6*
10	Blade	—	13,9	14,6*	7,4	10,7*	4,6	7,8			3,8*
	Outriggers	Blade	14,6*	14,6*	10,7*	10,7*	8,0*	8,0*			3,8*
5	Blade	—	11,8	20,6*	6,6	11,6	4,3	7,4			3,5
	Outriggers	Blade	13,5	20,6*	7,4	12,8*	4,9	9,7*			4,0
0	Blade	—	10,8	21,6	6,1	11,0	4,1	7,1			3,6
	Outriggers	Blade	12,4	21,9*	6,9	14,0*	4,6	10,1*			4,0
-5	Blade	—	10,6	20,5*	5,9	10,7					4,0
	Outriggers	Blade	12,2	20,5*	6,7	13,4*					4,5
-10	Blade	—	10,9	15,6*	6,0	10,3*					5,6
	Outriggers	Blade	12,5	15,6*	6,8	10,3*					6,3

Height Can be slewed through 360° In longitudinal position of undercarriage Max. reach \* Limited by hydr. capacity

The lift capacities on the load lift hook of the Liebherr quick coupler SWA 33 without working tool are stated in lb x 1,000 and are valid on a firm, level supporting surface with blocked oscillating axle. These capacities can be slewed through 360° with the undercarriage in the transverse position. Capacities in the longitudinal position of the undercarriage (+/- 15°) are specified over the steering axle with the stabilizers raised and over the rigid axle with the stabilizers down. Indicated loads based on the ISO 10567 standard and do not exceed 75 % of tipping or 87 % of hydraulic capacity, or are limited by the permissible load of the load lift hook on the quick coupler (max. 11,000 lb). Without the quick coupler, lift capacities will increase by up to 240 lb.



# Lift Capacities

## with Offset Mono Boom 14'1", EW-Undercarriage

**Stick 7'5"**

ft	Undercarriage stabilized		10 ft		15 ft		20 ft		25 ft		ft in
	rear	front									
25	Blade	—									
	Outriggers	Blade									
20	Blade	—			6,2*	6,2*				4,1*	4,1*
	Outriggers	Blade			6,2*	6,2*				4,1*	4,1*
15	Blade	—			8,8	9,3*	4,1*	4,1*		4,0*	4,0*
	Outriggers	Blade			9,3*	9,3*	4,1*	4,1*		4,0*	4,0*
10	Blade	—	15,5*	15,5*	8,2	11,1*	5,2	7,9		4,2*	4,2*
	Outriggers	Blade	15,5*	15,5*	11,1*	11,1*	7,9*	7,9*		4,2*	4,2*
5	Blade	—	13,5	21,3*	7,5	11,8	4,9	7,6		4,2	4,8*
	Outriggers	Blade	15,5	21,3*	8,5	13,1*	5,6	9,9*		4,8	4,8*
0	Blade	—	12,6	21,7*	7,0	11,3	4,7	7,4		4,3	5,9*
	Outriggers	Blade	14,6	21,7*	8,0	14,1*	5,3	10,2*		4,8	5,9*
-5	Blade	—	12,5	20,0*	6,9	11,1				4,9	7,7
	Outriggers	Blade	14,5	20,0*	7,8	13,2*				5,6	8,7*
-10	Blade	—	12,9	14,7*						7,1	9,7*
	Outriggers	Blade	14,7*	14,7*						8,0	9,7*

**Stick 8"**

ft	Undercarriage stabilized		10 ft		15 ft		20 ft		25 ft		ft in
	rear	front									
25	Blade	—									4,6*
	Outriggers	Blade									4,6*
20	Blade	—								6,3*	6,3*
	Outriggers	Blade								6,3*	6,3*
15	Blade	—								8,7*	8,7*
	Outriggers	Blade								8,7*	8,7*
10	Blade	—	14,6*	14,6*	8,3	10,7*	5,3	8,0		4,9*	4,9*
	Outriggers	Blade	14,6*	14,6*	10,7*	10,7*	8,0*	8,0*		4,9*	4,9*
5	Blade	—	13,7	20,6*	7,6	11,9	4,9	7,6		8,7*	8,7*
	Outriggers	Blade	15,7	20,6*	8,5	12,8*	5,5	9,7*		8,7*	8,7*
0	Blade	—	12,6	21,9*	7,0	11,2	4,7	7,3		4,9*	4,9*
	Outriggers	Blade	14,6	21,9*	7,9	14,0*	5,3	10,1*		8,7*	8,7*
-5	Blade	—	12,4	20,5*	6,8	11,0				8,7*	8,7*
	Outriggers	Blade	14,3	20,5*	7,7	13,4*				8,7*	8,7*
-10	Blade	—	12,7	15,6*	6,9	10,3*				8,7*	8,7*
	Outriggers	Blade	14,6	15,6*	7,9	10,3*				8,7*	8,7*

**Height** **Can be slewed through 360°** **In longitudinal position of undercarriage** **Max. reach** \* Limited by hydr. capacity

The lift capacities on the load lift hook of the Liebherr quick coupler SWA 33 without working tool are stated in lb x 1,000 and are valid on a firm, level supporting surface with blocked oscillating axle. These capacities can be slewed through 360° with the undercarriage in the transverse position. Capacities in the longitudinal position of the undercarriage (+/- 15°) are specified over the steering axle with the stabilizers raised and over the rigid axle with the stabilizers down. Indicated loads based on the ISO 10567 standard and do not exceed 75 % of tipping or 87 % of hydraulic capacity, or are limited by the permissible load of the load lift hook on the quick coupler (max. 11,000 lb). Without the quick coupler, lift capacities will increase by up to 240 lb.

# Clamshell Grab

## with Two-Piece Boom 15'11"

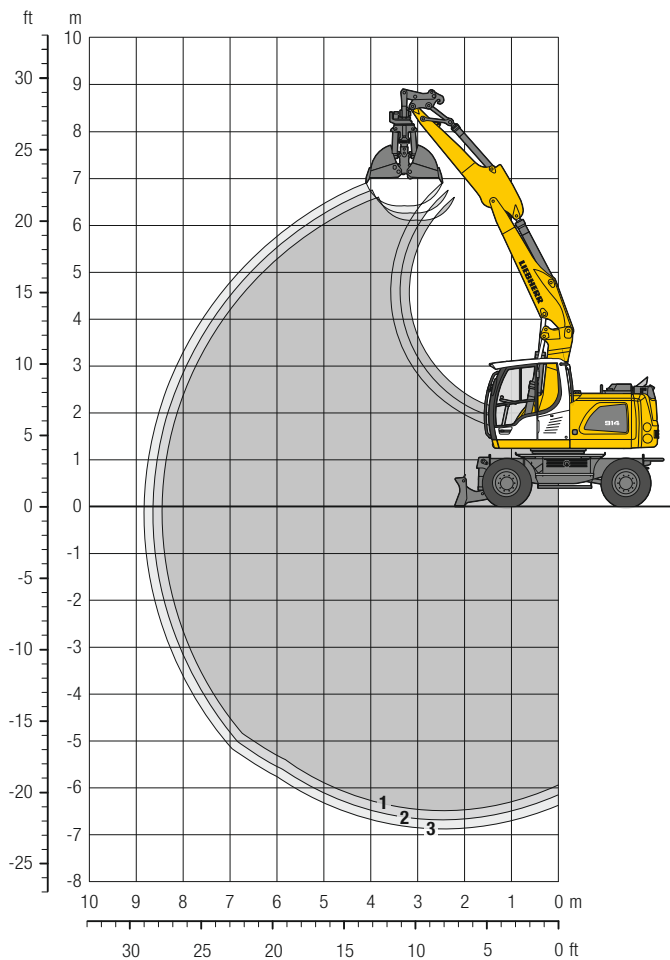

### Digging Envelope

with quick coupler		1	2	3
Stick length	ft in	7'5"	8'	8'8"
Max. digging depth	ft in	21'4"	22'	22'8"
Max. reach at ground level	ft in	27'9"	28'5"	29'
Max. dumping height	ft in	20'2"	20'8"	21'2"

### Operating Weight

The operating weight includes the basic machine with 8 tires plus intermediate rings, two-piece boom 15'11", stick 8' and clamshell grab GM 8B/0.52 yd<sup>3</sup> (31.5" without ejector).

Undercarriage versions	Weight (lb)
A 914 Litronic with rear blade	34,900/32,900*
A 914 Litronic with rear outriggers + front blade	37,500/35,500*
A 914 EW Litronic with rear blade	35,700/33,700*
A 914 EW Litronic with rear outriggers + front blade	37,900/35,900*

\* Operating weight without clamshell grab

### Clamshell Grab GM 8B Machine stability per ISO 10567\* (75% of tipping capacity)

Width of clamshells in	Capacity yd <sup>3</sup>	Weight lb	Stabilizers raised			Rear blade down			Rear outriggers + front blade down			EW Stabilizers raised			EW Rear blade down			EW Rear outriggers + front blade down		
			Stick length (ft in)			Stick length (ft in)			Stick length (ft in)			Stick length (ft in)			Stick length (ft in)			Stick length (ft in)		
			7'5"	8'	8'8"	7'5"	8'	8'8"	7'5"	8'	8'8"	7'5"	8'	8'8"	7'5"	8'	8'8"	7'5"	8'	8'8"
12.6 <sup>(1)</sup>	0.22	1,830	■	■	■	■	■	■	■	■	■	■	■	■	■	■	■	■	■	■
15.7 <sup>(1)</sup>	0.29	1,918	■	■	■	■	■	■	■	■	■	■	■	■	■	■	■	■	■	■
23.6 <sup>(1)</sup>	0.39	1,896	■	■	■	■	■	■	■	■	■	■	■	■	■	■	■	■	■	■
31.5 <sup>(1)</sup>	0.52	2,006	■	■	■	■	■	■	■	■	■	■	■	■	■	■	■	■	■	■
39.4 <sup>(1)(3)</sup>	1.05	2,227	-	-	-	△	-	-	■	■	■	△	△	-	■	△	■	■	■	■
12.6 <sup>(2)</sup>	0.22	1,940	■	■	■	■	■	■	■	■	■	■	■	■	■	■	■	■	■	■
15.7 <sup>(2)</sup>	0.29	2,050	■	■	■	■	■	■	■	■	■	■	■	■	■	■	■	■	■	■
23.6 <sup>(2)</sup>	0.39	2,094	■	■	■	■	■	■	■	■	■	■	■	■	■	■	■	■	■	■
31.5 <sup>(2)</sup>	0.52	2,249	■	■	■	■	■	■	■	■	■	■	■	■	■	■	■	■	■	■

\* Indicated loads are based on ISO 10567 and do not exceed 75% of tipping or 87% of hydraulic capacity, max. stick length without quick coupler, lifted 360° on firm with blocked oscillating axle

<sup>1)</sup> without ejector

<sup>2)</sup> with ejector

<sup>3)</sup> Shells for loose material

Max. material weight ■ = ≤ 3,034 lb/yd<sup>3</sup>, ■ = ≤ 2,528 lb/yd<sup>3</sup>, △ = ≤ 2,023 lb/yd<sup>3</sup>, - = not authorized



# Equipments

## Clamshell Grabs

### Clamshell Grab GM 8B Machine stability per ISO 10567\* (75% of tipping capacity)

Width of clamshells in	Capacity yd <sup>3</sup>	Weight lb	Stabilizers raised			Rear blade down			Rear outriggers + front blade down			EW Stabilizers raised			EW Rear blade down			EW Rear outriggers + front blade down		
			Stick length (ft in)			Stick length (ft in)			Stick length (ft in)			Stick length (ft in)			Stick length (ft in)			Stick length (ft in)		
			7'5"	8'	8'8"	7'5"	8'	8'8"	7'5"	8'	8'8"	7'5"	8'	8'8"	7'5"	8'	8'8"	7'5"	8'	8'8"
<b>Mono boom 15'1"</b>																				
12.6 <sup>(1)</sup>	0.22	1,830	■	■	■	■	■	■	■	■	■	■	-	-	-	-	-	-	-	-
15.7 <sup>(1)</sup>	0.29	1,918	■	■	■	■	■	■	■	■	■	■	-	-	-	-	-	-	-	-
23.6 <sup>(1)</sup>	0.39	1,896	■	■	■	■	■	■	■	■	■	■	-	-	-	-	-	-	-	-
31.5 <sup>(1)</sup>	0.52	2,006	■	■	■	■	■	■	■	■	■	■	-	-	-	-	-	-	-	-
39.4 <sup>(1)(3)</sup>	1.05	2,227	△	-	-	△	△	△	■	■	■	■	-	-	-	-	-	-	-	-
12.6 <sup>(2)</sup>	0.22	1,940	■	■	■	■	■	■	■	■	■	■	-	-	-	-	-	-	-	-
15.7 <sup>(2)</sup>	0.29	2,050	■	■	■	■	■	■	■	■	■	■	-	-	-	-	-	-	-	-
23.6 <sup>(2)</sup>	0.39	2,094	■	■	■	■	■	■	■	■	■	■	-	-	-	-	-	-	-	-
31.5 <sup>(2)</sup>	0.52	2,249	■	■	■	■	■	■	■	■	■	■	-	-	-	-	-	-	-	-
<b>Offset two-piece boom 16'1"</b>																				
12.6 <sup>(1)</sup>	0.22	1,830	■	■	-	■	■	-	■	■	-	■	■	-	■	■	-	■	■	-
15.7 <sup>(1)</sup>	0.29	1,918	■	■	-	■	■	-	■	■	-	■	■	-	■	■	-	■	■	-
23.6 <sup>(1)</sup>	0.39	1,896	■	■	-	■	■	-	■	■	-	■	■	-	■	■	-	■	■	-
31.5 <sup>(1)</sup>	0.52	2,006	■	■	-	■	■	-	■	■	-	■	■	-	■	■	-	■	■	-
39.4 <sup>(1)(3)</sup>	1.05	2,227	-	-	-	-	-	-	■	■	-	-	-	-	△	△	-	■	■	-
12.6 <sup>(2)</sup>	0.22	1,940	■	■	-	■	■	-	■	■	-	■	■	-	■	■	-	■	■	-
15.7 <sup>(2)</sup>	0.29	2,050	■	■	-	■	■	-	■	■	-	■	■	-	■	■	-	■	■	-
23.6 <sup>(2)</sup>	0.39	2,094	■	■	-	■	■	-	■	■	-	■	■	-	■	■	-	■	■	-
31.5 <sup>(2)</sup>	0.52	2,249	■	△	-	■	■	-	■	■	-	■	■	-	■	■	-	■	■	-
<b>Offset mono boom 14'1"</b>																				
12.6 <sup>(1)</sup>	0.22	1,830	■	■	-	■	■	-	■	■	-	■	■	-	■	■	-	■	■	-
15.7 <sup>(1)</sup>	0.29	1,918	■	■	-	■	■	-	■	■	-	■	■	-	■	■	-	■	■	-
23.6 <sup>(1)</sup>	0.39	1,896	■	■	-	■	■	-	■	■	-	■	■	-	■	■	-	■	■	-
31.5 <sup>(1)</sup>	0.52	2,006	■	■	-	■	■	-	■	■	-	■	■	-	■	■	-	■	■	-
39.4 <sup>(1)(3)</sup>	1.05	2,227	△	-	-	■	△	-	■	■	-	■	△	-	■	■	-	■	■	-
12.6 <sup>(2)</sup>	0.22	1,940	■	■	-	■	■	-	■	■	-	■	■	-	■	■	-	■	■	-
15.7 <sup>(2)</sup>	0.29	2,050	■	■	-	■	■	-	■	■	-	■	■	-	■	■	-	■	■	-
23.6 <sup>(2)</sup>	0.39	2,094	■	■	-	■	■	-	■	■	-	■	■	-	■	■	-	■	■	-
31.5 <sup>(2)</sup>	0.52	2,249	■	■	-	■	■	-	■	■	-	■	■	-	■	■	-	■	■	-

\* Indicated loads are based on ISO 10567 and do not exceed 75% of tipping or 87% of hydraulic capacity, max. stick length without quick coupler, lifted 360° on firm with blocked oscillating axle

<sup>1)</sup> without ejector

<sup>2)</sup> with ejector

<sup>3)</sup> Shells for loose material

Max. material weight ■ = ≤ 3,034 lb/yd<sup>3</sup>, ■ = ≤ 2,528 lb/yd<sup>3</sup>, △ = ≤ 2,023 lb/yd<sup>3</sup>, - = not authorized

# Equipments

## Ditch Cleaning Buckets/Tilt Buckets

### Ditch Cleaning Buckets Machine stability per ISO 10567\* (75% of tipping capacity)

Cutting width in	Capacity ISO 7451 <sup>1)</sup> yd <sup>3</sup>	Weight lb	Stabilizers raised			Rear blade down			Rear outriggers + front blade down			EW Stabilizers raised			EW Rear blade down			EW Rear outriggers + front blade down		
			Stick length (ft in)			Stick length (ft in)			Stick length (ft in)			Stick length (ft in)			Stick length (ft in)			Stick length (ft in)		
			7'5"	8'	8'8"	7'5"	8'	8'8"	7'5"	8'	8'8"	7'5"	8'	8'8"	7'5"	8'	8'8"	7'5"	8'	8'8"
<b>Two-piece boom 15'11"</b>																				
59.1 <sup>3)</sup>	0.65	794	■	■	■	■	■	■	■	■	■	■	■	■	■	■	■	■	■	
63.0 <sup>2)</sup>	0.72	1,411	■	■	■	■	■	■	■	■	■	■	■	■	■	■	■	■	■	
78.7 <sup>2)</sup>	0.65	1,455	■	■	■	■	■	■	■	■	■	■	■	■	■	■	■	■	■	
78.7 <sup>3)</sup>	0.63	772	■	■	■	■	■	■	■	■	■	■	■	■	■	■	■	■	■	
78.7 <sup>3)</sup>	0.85	860	■	■	■	■	■	■	■	■	■	■	■	■	■	■	■	■	■	
<b>Mono boom 15'1"</b>																				
59.1 <sup>3)</sup>	0.65	794	■	■	■	■	■	■	■	■	■	■	■	■	■	■	■	■	■	
63.0 <sup>2)</sup>	0.72	1,411	■	■	■	■	■	■	■	■	■	■	■	■	■	■	■	■	■	
78.7 <sup>2)</sup>	0.65	1,455	■	■	■	■	■	■	■	■	■	■	■	■	■	■	■	■	■	
78.7 <sup>3)</sup>	0.63	772	■	■	■	■	■	■	■	■	■	■	■	■	■	■	■	■	■	
78.7 <sup>3)</sup>	0.85	860	■	■	■	■	■	■	■	■	■	■	■	■	■	■	■	■	■	
<b>Offset two-piece boom 16'1"</b>																				
59.1 <sup>3)</sup>	0.65	794	■	■	■	■	■	■	■	■	■	■	■	■	■	■	■	■	■	
63.0 <sup>2)</sup>	0.72	1,411	■	■	■	■	■	■	■	■	■	■	■	■	■	■	■	■	■	
78.7 <sup>2)</sup>	0.65	1,455	■	■	■	■	■	■	■	■	■	■	■	■	■	■	■	■	■	
78.7 <sup>3)</sup>	0.63	772	■	■	■	■	■	■	■	■	■	■	■	■	■	■	■	■	■	
78.7 <sup>3)</sup>	0.85	860	■	■	■	■	■	■	■	■	■	■	■	■	■	■	■	■	■	
<b>Offset mono boom 14'1"</b>																				
59.1 <sup>3)</sup>	0.65	794	■	■	■	■	■	■	■	■	■	■	■	■	■	■	■	■	■	
63.0 <sup>2)</sup>	0.72	1,411	■	■	■	■	■	■	■	■	■	■	■	■	■	■	■	■	■	
78.7 <sup>2)</sup>	0.65	1,455	■	■	■	■	■	■	■	■	■	■	■	■	■	■	■	■	■	
78.7 <sup>3)</sup>	0.63	772	■	■	■	■	■	■	■	■	■	■	■	■	■	■	■	■	■	
78.7 <sup>3)</sup>	0.85	860	■	■	■	■	■	■	■	■	■	■	■	■	■	■	■	■	■	

### Tilt Buckets Machine stability per ISO 10567\* (75% of tipping capacity)

Cutting width in	Capacity ISO 7451 <sup>1)</sup> yd <sup>3</sup>	Weight lb	Stabilizers raised			Rear blade down			Rear outriggers + front blade down			EW Stabilizers raised			EW Rear blade down			EW Rear outriggers + front blade down		
			Stick length (ft in)			Stick length (ft in)			Stick length (ft in)			Stick length (ft in)			Stick length (ft in)			Stick length (ft in)		
			7'5"	8'	8'8"	7'5"	8'	8'8"	7'5"	8'	8'8"	7'5"	8'	8'8"	7'5"	8'	8'8"	7'5"	8'	8'8"
<b>Two-piece boom 15'11"</b>																				
59.1 <sup>2)</sup>	0.78	1,455	■	■	■	■	■	■	■	■	■	■	■	■	■	■	■	■	■	
<b>Mono boom 15'1"</b>																				
59.1 <sup>2)</sup>	0.78	1,455	■	■	■	■	■	■	■	■	■	■	■	■	■	■	■	■	■	
<b>Offset two-piece boom 16'1"</b>																				
59.1 <sup>2)</sup>	0.78	1,455	■	△	■	■	■	■	■	■	■	■	■	■	■	■	■	■	■	
<b>Offset mono boom 14'1"</b>																				
59.1 <sup>2)</sup>	0.78	1,455	■	■	■	■	■	■	■	■	■	■	■	■	■	■	■	■	■	

\* Indicated loads are based on ISO 10567 and do not exceed 75% of tipping or 87% of hydraulic capacity, max. stick length without quick coupler, lifted 360° on firm with blocked oscillating axle

<sup>1)</sup> comparable with SAE (heaped)

<sup>2)</sup> with 2 x 50° rotator

<sup>3)</sup> rigid ditch cleaning bucket

Max. material weight ■ = ≤ 3,034 lb/yd<sup>3</sup>, ■ = ≤ 2,528 lb/yd<sup>3</sup>, △ = ≤ 2,023 lb/yd<sup>3</sup>, - = not authorized

# Equipment

## Undercarriage

Dual-circuit braking system	•
Rear stabilizer blade	+
Rear + front stabilizer blade	+
Lighting trailer coupling	+
Trailer coupling with bolt, automatic	+
Digging brake, automatic	•
Tires (twin tires) Liebherr EM 22 290/90-20	+
Tires (twin tires) Mitas EM 22	•
Individual control outriggers	+
Travel speed levels (four)	•
Tilt function of trailer, hydraulic	+
Mudguards (rear and front)	+
Load holding valve on each stabilization cylinder	•
Powershift transmission, semiautomatic	•
Parking brake, maintenance-free	•
Rear outriggers + front stabilizer blade	+
Tires, variants	+
Protection for piston rods, stabilizer cylinder	+
Speeder**	+
Storage compartment left – lockable	•
Storage compartment right – lockable	+
Undercarriage EW 9'	+
Tool equipment, extended	+

## Uppercarriage

Uppercarriage right side light, 1 piece, LED	+
Uppercarriage rear light, 2 pieces, LED	+
Refuelling system with filling pump	+
Main battery switch for electrical system	•
Engine hood with gas spring	•
Amber beacon, at uppercarriage, LED double flash	+
Service doors, lockable	•

## Hydraulic System

Shut-off valve between hydraulic tank and pump(s)	•
Pressure test fittings	•
Accumulator for controlled lowering of the equipment with the engine shut down	•
Hydraulic oil filter with integrated microfilter	•
Liebherr hydraulic oil from -4 °F to +104 °F	•
Liebherr hydraulic oil, biologically degradable	+
Liebherr hydraulic oil, specially for warm or cold regions	+
Bypass filter	+
Switchover high pressure circuit and tipping cylinder	+
Switchover high pressure circuit and two-piece boom	+

## Diesel Engine

Fuel anti-theft device	+
Liebherr particle filter	+
Reversible fan drive, fully automatic	+
Automatic engine shut-down (time adjustable)	+
Preheating fuel	+
Preheating coolant	+
Preheating engine oil	+

## Operator's Cab

Storage compartment	•
Stabilizer, proportional control on left joystick	•
Cab lights rear, LED	+
Cab lights front, halogen (under rain cover)	•
Cab lights front, LED (above rain cover)	+
Cab lights front, LED (under rain cover)	+
Exterior mirror, electrical adjustable, with heating	+
Mechanical hour meters, readable from outside the cab	•
Roof window made from impact-resistant laminated safety glass	•
Slewing gear brake Comfort, button on the left or right joystick	+
Operator's seat Standard	•
Operator's seat Comfort	+
Operator's seat Premium	+
Driving alarm (acoustic signal is emitted during travel, can be switched ON/OFF)	+
Fire extinguisher	+
Front screen made from impact-resistant laminated safety glass – not adjustable	+
Windscreen retractable (including upper part)	•
Intermittent windscreen wiper with wiper washer	•
Cruise control	•
Dome light	•
Joystick steering	+
Coat hook	•
Automatic air conditioning	•
Fuel consumption indicator	•
Electric cooler	+
Steering wheel, wide version (cost-neutral option)	+
Steering column adjustable horizontally	•
LiDAT, vehicle fleet management	•
Emergency exit rear window	•
Positioning swing brake	+
Proportional control	•
Radio Comfort, control via display with handsfree set	+
Preparation for radio installation	•
Rain cover over front window opening	•
ROPS cab protection	•
Back-up alarm (acoustic signal is emitted traveling backward, can not be switched off)	+
Amber beacon, on cabin, LED double flash	+
All tinted windows	•
Windscreen wiper, roof	+
Windshield wiper, entire windscreen	•
Door with sliding window	•
Top guard	+
Front guard, adjustable	+
Right side window and windshield made from laminated safety glass	•
Sun visor	+
Sun blind	•
Auxiliary heating, adjustable (week time switch)	+
Left control console, folding	•
Electronic immobilizer	+
Cigarette lighter	•





## Equipment

Boom lights, 2 pieces, halogen	•
Boom lights, 2 pieces, LED	+
Stick lights, 2 pieces, LED	+
Travel vibration damper	+
High pressure circuit incl. unpressurized return line and Tool Control	+
Electronic lift limitation	+
Security for hoist cylinder for hydraulic attachments	+
Load holding valve bucket cylinder	+
Load lug on stick	+
Leak oil line, additional for attachments	+
Liebherr ditch cleaning bucket	+
Liebherr quick coupler, hydraulic or mechanical	+
Liebherr tilt bucket	+
Liebherr tilt rotator	+
Liebherr sorting grab	+
Liebherr backhoe bucket	+
Liebherr tooth system	+
Liebherr clamshell grab	+
Medium pressure circuit incl. lines	+
Mono boom	+
Pipe fracture safety valves hoist cylinders	•
Pipe fracture safety valve stick cylinder	•
Return line, pressureless (in high pressure circuit option included)	+
Hose quick coupling at end of stick	•
Quick coupling system LIKUFIX	+
Protection for piston rod, bucket cylinder	+
Protection for bottom side of stick	+
Tool Control, 20 attachment adjustments selectable over the display	+
Overload warning device	•
Two-piece boom	+
Offset two-piece boom	+



## Complete Machine

<b>Lubrication</b>	
Lubrication undercarriage, manually – decentralized (grease points)	•
Lubrication undercarriage, manually – centralized (one grease point)	+
Central lubrication system for uppercarriage and equipment, automatically (without quick coupler and connecting link)*	•
Central lubrication system, extension for quick coupler	+
Central lubrication system, extension for connecting link	+
<b>Special coating</b>	
Custom painting for attachments	+
Special coating, variants	+
<b>Monitoring</b>	
Rear view monitoring with camera	•
Side view monitoring with camera	•
Skyview 360° (side camera not available)	+

• = Standard, + = Option

\* = country-dependent, \*\* = depending upon the country partially only 15.5 mph permitted

Options and / or special attachments, supplied by vendors other than Liebherr, are only to be installed with the knowledge and approval of Liebherr in order to retain warranty.

# The Liebherr Group of Companies



## Diverse Product Range

The Liebherr Group is one of the largest construction equipment manufacturers in the world. Liebherr's quality products and services hold a high reputation in many industries. The wide range includes domestic appliances, aerospace and transportation systems, machine tools and maritime cranes.

## Exceptional Customer Benefit

Every product line provides a complete range of models in many different versions. With both their technical excellence and superior quality, Liebherr products offer customers the highest benefits in practical applications.

## State-of-the-art Technology

Liebherr attributes great importance to the product areas of core technology and components, in order to achieve its consistent, top-quality products. Important modules and components are developed and manufactured in-house, for instance, the entire drive and control technology for the construction equipment and mining trucks.

## Worldwide and Family-Owned

Hans Liebherr founded the Liebherr family company in 1949. Since that time, the enterprise has steadily grown to a group of more than 130 companies with more than 46,000 employees located on all continents. The corporate headquarters of the Group is Liebherr-International AG in Bulle, Switzerland. The Liebherr family is the sole owner of the company.

[www.liebherr.us](http://www.liebherr.us)

## Liebherr USA, Co.

Construction Equipment Division  
4100 Chestnut Avenue, Newport News, VA 23607, USA  
☎ +1 (757) 245 5251, Fax +1 (757) 928 8701  
[www.liebherr.us](http://www.liebherr.us), E-Mail: [Construction.USA@liebherr.com](mailto:Construction.USA@liebherr.com)  
[www.facebook.com/LiebherrConstruction](https://www.facebook.com/LiebherrConstruction)