

# Product Information Material Handling Machines

## LH 22

Litronic®

## LH 26

Litronic®

## LH 30

Litronic®

### Tree Care and the Wood Industry

#### Generation

6

#### Operating Weight

42,300 – 66,600 lb\*

\* Without attachment



# LIEBHERR



## Performance

Power Plus Speed –  
Redefined Performance

## Economy

Good Investment –  
Savings for the Long-Term

### LH 22 M Industry

**Operating Weight**  
42,300 – 48,300 lb\*

### LH 26 M Industry

**Operating Weight**  
53,400 – 54,000 lb\*

### LH 30 M Industry

**Operating Weight**  
58,400 – 64,200 lb\*

### LH 30 C Industry

**Operating Weight**  
59,700 – 66,600 lb\*

\* Without attachment





## Reliability

Durability and Sustainability –  
Quality Down to the Last Detail

## Comfort

Perfection at a Glance –  
When Technology is Comfortable

## Maintainability

Efficiency Bonus –  
Even with Maintenance and Service





# Well Thought Out to the Last Detail







### LIKUFIX – Liebherr's Fully Hydraulic Quick Coupling System

- Change attachments from the cab safely, conveniently and quickly
- Significantly increase machine versatility and productivity



### 30° Tilt Function Cab and Protective Devices

- The tilt function cab delivers a perfect view of the job site area and excellent conditions for healthy, focused and productive work
- Optional safety grilles on the front and roof of the cab provide the operator with maximum safety



### Range of Undercarriage Versions

- 4 point outriggers
- 4 point outriggers +dozer blade
- 2 point outriggers +stabilizer and dozer blade
- Crawler



# Convincing in Operation



## Performance

### Productive and Versatile

From embankment care, road clearing, problem tree felling to classic recycling use, the selected handling machine is exceptionally flexible.

The extensive range of equipment combinations, such as the Liebherr stick extension, the Westtech telescopic stage or the direct attachment of a cutting tool allow even difficult to reach areas to be accessed with ease. The result is a significant increase in productivity.

### Sensitive Hydraulics

The optimal harmonisation between the engine and the control valve allows a fast and direct response from the input command to the hydraulics. This is controlled proportionally to enable smooth and gentle movements when the joystick is moved.

## Economy

### Attachments and Quick Coupling Systems

Liebherr offers a wide selection of attachments for every application to increase the versatility of its material handling machines. For even greater flexibility the machines can be fitted with a Liebherr LIKUFIX quick coupling system which increases productivity by up to 30%. The right attachment and quick coupling system combined with the outstanding dynamics of a Liebherr handler ensures the highest handling capacity and maximum productivity.

### Engine Idling and Engine Shut-Down

The standard automatic idling function reduces the engine speed to idle as soon as the operator takes their hand from the joystick so that no hydraulic function is activated. Proximity sensors in the joystick levers restore the original engine speed as soon as the operator's hand is moved towards the lever again. This ensures that the set engine speed is available immediately. The result is a combination of fuel savings and reduced noise levels. Operating costs can be reduced even further with the optional automatic engine shut-down function.

## Reliability

### **Quality and Competence**

Our experience, understanding of customer needs and the technical implementation of these findings guarantee the success of our products. For decades, Liebherr has been inspirational with its extent of production, system solutions and highest quality.

### **High Safety Level**

The pipe fracture safety devices on the hoist and stick cylinders, together with the load holding valve on the bucket cylinder, prevent the equipment lowering out of control to guarantee maximum safety.

### **Durability**

All steel components are designed and manufactured by Liebherr. High-strength steel plates are configured for the toughest of requirements resulting in high torsional stiffness and optimum absorption of forces induced for a longer service life. The optional guard for the piston rods on the bucket, hoist and stick cylinders ensures that the components deliver a long service life even in extremely adverse conditions.

### **Overload Warning Device and Load Torque Limitation**

The audible and visual overload warning system continuously tells the operator about the current load situation of the machine. Furthermore, load torque limitation automatically regulates the speed of the working hydraulics to allow the maximum load bearing capacity to be approached safely. In the event of an overload, the functions which could cause the machine to topple are disabled. Only movements back to the safe working range are then possible.

## Comfort

### **Excellent All-Round Vision**

The large windows and range of cab elevation versions, particularly the optional 30° tilt function cab, provide the operator with excellent visibility together with a low fatigue seat position which prevents neck pain. The rear and side area monitoring systems provide the operator with an excellent view of their working area and the zone around the machine.

### **Proportional Control System**

Precise and accurate machine control is particularly important in applications such as tree care and the wood industry. The material handler's standard proportional control system combined with the appropriate attachments enable even this demanding work to be completed with ease.

### **Slewing Gear Brake Comfort**

The standard slewing gear brake comfort control allows the selection between modes including manual, semi-automatic and automatic. The standard slewing gear brake in the manual mode can be opened and closed with the button on the joystick. In the semi-automatic mode the slewing gear brake can also be closed manually, but automatically opened again when the uppercarriage is moved via the joystick control. The automatic mode allows the slewing gear brake to be closed automatically when the predefined time, set by the operator, has passed and the uppercarriage has stopped moving. It will open automatically as soon as the uppercarriage is moved via the joystick control. By opening and closing the slewing gear brake automatically the operator can work safely and faster with less effort.

## Maintainability

### **Service-Based Machine Design**

The service-based machine design guarantees short servicing times, thus minimizing maintenance costs. All the service points are positioned in close proximity to one another, accessible from the ground or on catwalks and platforms, and easy to reach thanks to the large, wide-opening service doors. The enhanced service concept places the maintenance points close to each other and reduces their number to a minimum. This means that service work can be completed quickly and efficiently.

### **Integral Maintenance Benefits**

Maintenance work helps to keep the machine fully functional. The resultant downtime should ideally be kept to a minimum. With change intervals of up to 2,000 hours for engine oil and up to 8,000 hours for hydraulic oil, Liebherr has significantly reduced the amount of maintenance and increased the productivity of the material handlers. In addition, central lubrication systems minimize daily maintenance.

# The Perfect Solution for Every Application



## Flexible, Fast Attachment Changes

The fully hydraulic LIKUFIX quick coupling system from Liebherr enables the operator to change attachments quickly, conveniently and safely from the cab.

Machines operating in the tree care and wood industry can quickly and efficiently switch between the required attachments. This means after cutting back the operator can switch directly to a mill, a mulcher or a ditch cleaning bucket.



## Material Handling Machine with Westtech-Woodcracker® C350

Larger and heavier cutting tools can be attached directly to the Liebherr stick with tipping kinematics when working close to the machine. This means that a reach of 36'1" – 47'7" is possible, depending on the machine size.

The maximum stability required for this is achieved by the machine's well designed support geometry. This ensures that solid tree trunks can be handled with ease.

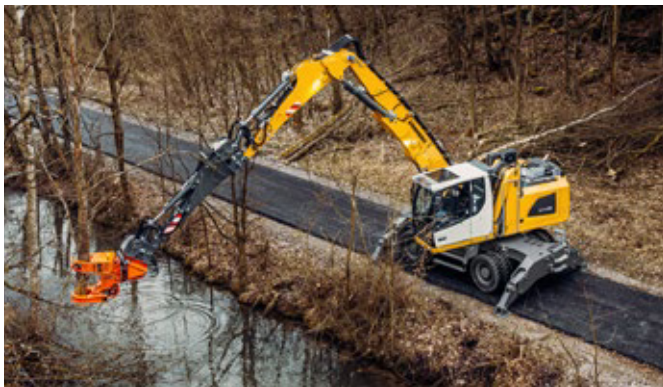

## Material Handling Machine with Liebherr Stick Extension and Westtech-Woodcracker® C250

The combination of the Liebherr stick extension and a light-weight cutting tool is the perfect solution for reaching distant trees and shrubs. This equipment combination gives a reach of 42'8" – 54'2", depending on machine size.

The Liebherr stick extension provides the reach required for carrying out trimming jobs smoothly and accurately.



## Material Handling Machine with Westtech-Telescope Stage T 4000 and Woodcracker® CS510 crane

Trimming high trees and thick branches is a particular challenge. Depending on their weight class, the material handling machines have a reach of 52'6" – 62'4" when fitted with LIKUFIX and 13'1" telescopic arm.

In this configuration, the machine can reach extremely high up into the trees so that it can cut back whatever is necessary. The hydraulically height-adjustable cab with 30° tilt function provides the operator with perfect visibility of the working area.



# Examples of Use



Find your contact person:





# Technical Data

## LH 22 M Industry – Range Overview

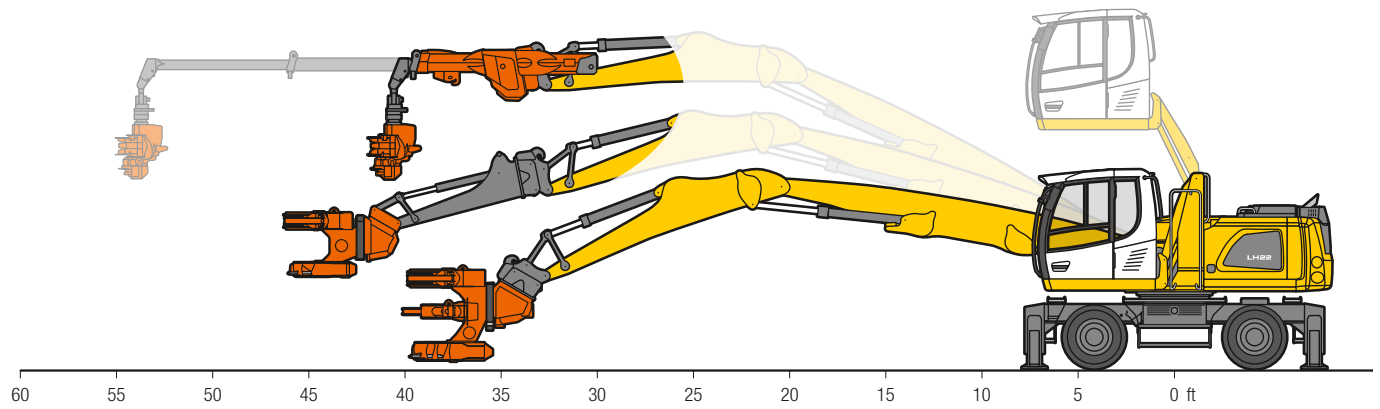

Operating weight*	lb	approx. 42,300 – 48,300		
Engine output (SAE J1349/ISO 9249)	kW/HP	105/141		
Emission stage	Stage	V	IIIA (compliant)	Tier 4f
Reach with direct mounting Woodcracker®	ft in	up to 37'9"		
Reach with stick extension and Woodcracker®	ft in	up to 44'3"		
Reach with telescope stage and Woodcracker®	ft in	up to 54'2"		

\* without attachment



# LH 22 M – Dimensions

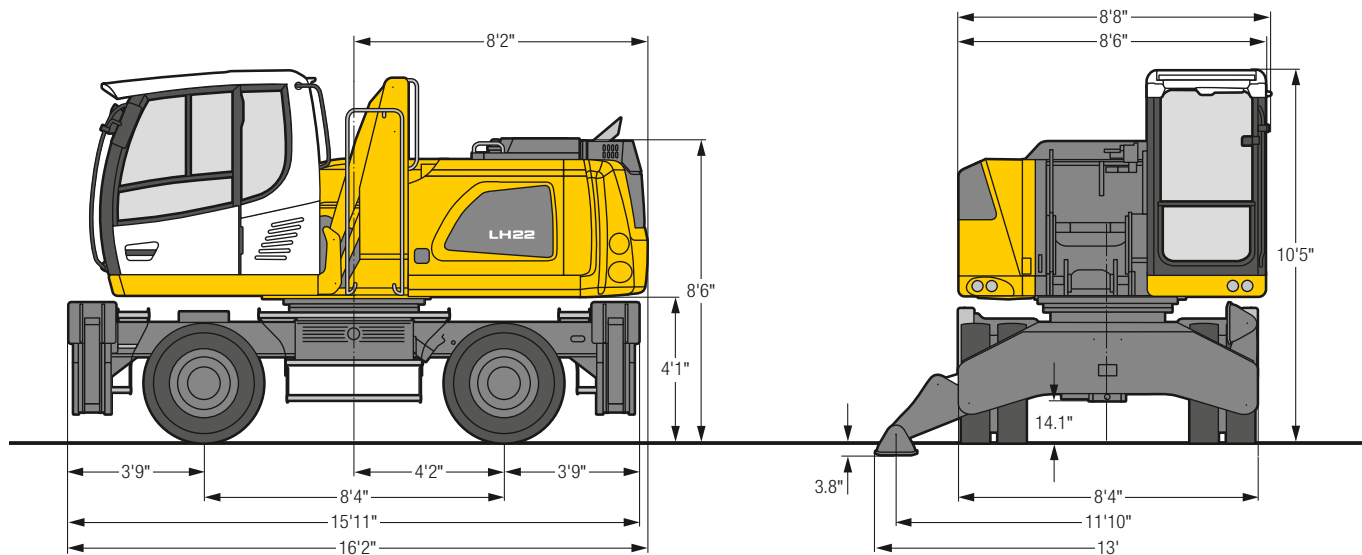

# LH 22 M – Choice of Cab Elevation

## Cab Elevation LHC (Hydraulic Elevation)

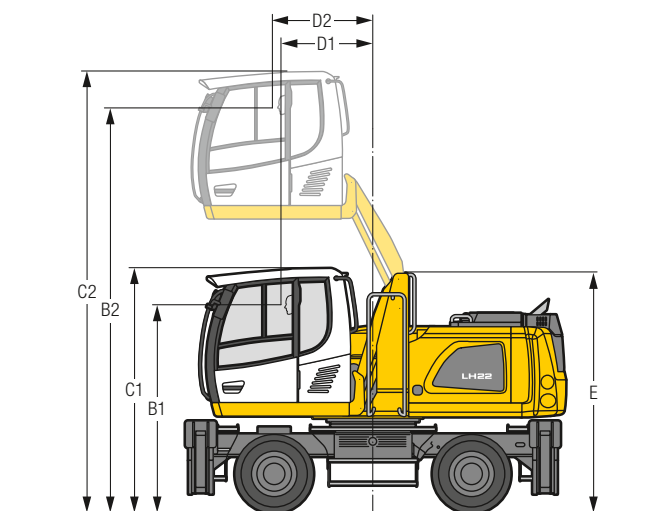

## Cab Elevation LHC (30° Tilt Function as an Option)

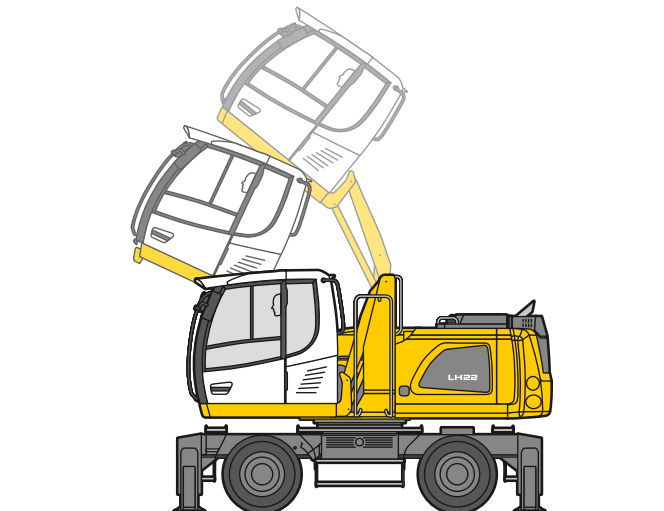

Increase type	LHC 255
B1	8'10"
B2	17' 2"
C1	10' 5"
C2	18' 9"
D1	3'11"
D2	4' 3"
E	10' 2"

The hydraulically adjustable cab allows the driver, that he can choose his field of view freely and at any time within the stroke.

Tires 10.00-20



# LH 22 M – Equipment GK10

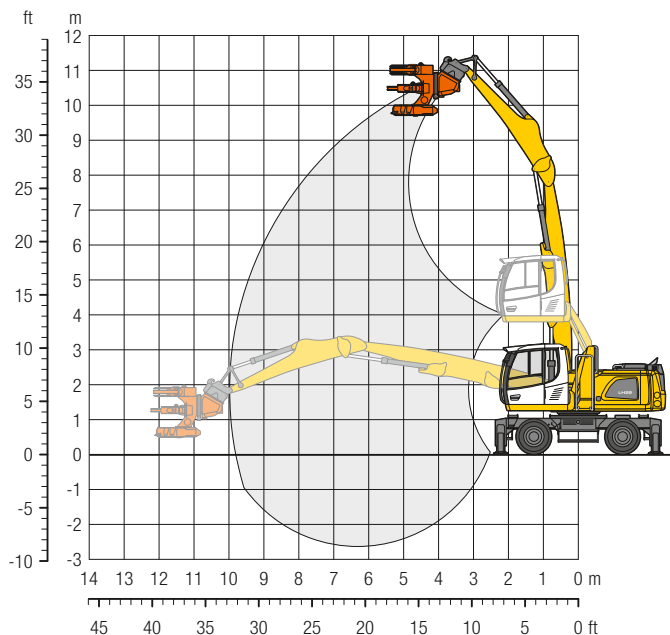

## Operating Weight

The operating weight includes the basic machine with 4 point outriggers, hydr. cab elevation, 8 solid tires plus intermediate rings, straight boom 19'8", stick with tipping kinematics 13'1", quick coupler SWA 48 LIKUFIX and Woodcracker® C350.

Weight 52,700 lb

ft in	Undercarriage	10 ft		15 ft		20 ft		25 ft		30 ft		35 ft		40 ft		45 ft		50 ft		ft in			
40	Stabilizers raised 4 pt. outriggers down																						
35	Stabilizers raised 4 pt. outriggers down																				13,3"	13,3"	14"
30	Stabilizers raised 4 pt. outriggers down					7,7	10,4														13,3"	13,3"	21'10"
25	Stabilizers raised 4 pt. outriggers down					7,9	10,6	5,2	7,1												4,6	6,4	26' 6"
20	Stabilizers raised 4 pt. outriggers down			12,4	14,9*	11,8*	11,8*	10,0*	10,0*												9,1*	9,1*	29' 6"
15	Stabilizers raised 4 pt. outriggers down			11,6	15,9	12,5*	12,5*	10,1*	10,1*	3,5	5,0									3,2	4,6	31' 6"	
10	Stabilizers raised 4 pt. outriggers down	19,0	25,5*	10,4	14,6	12,5*	12,5*	10,1*	10,1*	8,0	8,2*									7,4	7,6*	32' 6"	
5	Stabilizers raised 4 pt. outriggers down			9,2	13,3	11,8*	11,8*	10,0*	10,0*	3,4	4,9									2,9	4,2	32' 6"	
0	Stabilizers raised 4 pt. outriggers down			9,2	13,3	6,2	8,7	4,4	6,3	3,3	4,7									6,9*	6,9*	32' 8"	
-5	Stabilizers raised 4 pt. outriggers down	2,3*	2,3*	8,5	12,5	5,7	8,3	4,2	6,0	3,2	4,6									2,8	4,1	32' 2"	
-10	Stabilizers raised 4 pt. outriggers down	2,3*	2,3*	14,5*	14,5*	12,2*	12,2*	9,2*	9,2*	6,6*	6,6*									5,2*	5,2*	29' 8"	

Height Can be slewed through 360° In longitudinal position of undercarriage Max. reach \* Limited by hydr. capacity

The lift capacities on the stick end without attachment are stated in lb x 1,000 and are valid on a firm, level supporting surface with blocked oscillating axle. These capacities can be slewed through 360° with the undercarriage in the transverse position. Capacities in the longitudinal position of the undercarriage (+/- 15°) are specified over the steering axle with the stabilizers raised and over the rigid axle with the stabilizers down. Indicated loads based on the ISO 10567 standard and do not exceed 75% of tipping or 87% of hydraulic capacity. The lift capacity of the unit is limited by its stability, the lifting capability of the hydraulic elements, or the maximum permissible lifting capacity of the load hook.



# LH 22 M – Equipment GSV12

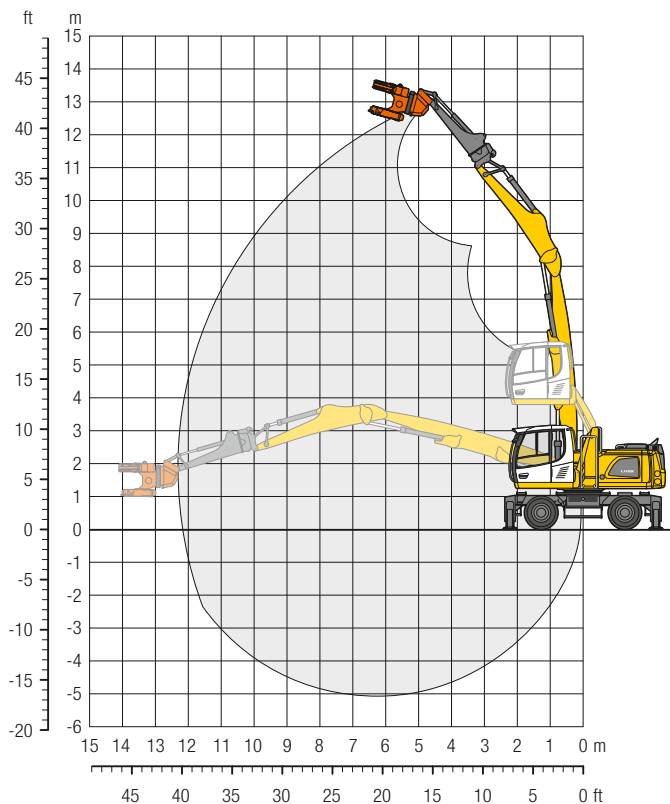

## Operating Weight

The operating weight includes the basic machine with 4 point outriggers, hydr. cab elevation, 8 solid tires plus intermediate rings, straight boom 19'8", stick with tipping kinematics 13'1", quick coupler SWA 48 LIKUFIX, stick extension 7'5" and Woodcracker® C250.

Weight 52,400 lb

ft in	Undercarriage	10 ft		15 ft		20 ft		25 ft		30 ft		35 ft		40 ft		45 ft		50 ft		ft in		
		Stabilizers raised	4 pt. outriggers down	Stabilizers raised	4 pt. outriggers down	Stabilizers raised	4 pt. outriggers down	Stabilizers raised	4 pt. outriggers down	Stabilizers raised	4 pt. outriggers down	Stabilizers raised	4 pt. outriggers down	Stabilizers raised	4 pt. outriggers down	Stabilizers raised	4 pt. outriggers down	Stabilizers raised	4 pt. outriggers down	Stabilizers raised	4 pt. outriggers down	ft in
40	Stabilizers raised					7,3*	7,3*													6,8*	6,8*	20'10"
	4 pt. outriggers down					7,3*	7,3*													6,8*	6,8*	
35	Stabilizers raised							5,3	6,8*											4,1	5,4*	27' 7"
	4 pt. outriggers down							6,8*	6,8*											5,4*	5,4*	
30	Stabilizers raised							5,5	7,5	3,5	5,0									2,8	4,2	32' 2"
	4 pt. outriggers down							7,6*	7,6*	6,1*	6,1*									4,8*	4,8*	
25	Stabilizers raised							5,6	7,6	3,6	5,1	2,2	3,4							2,1	3,3	35' 5"
	4 pt. outriggers down							7,6*	7,6*	6,7*	6,7*	4,8*	4,8*							4,4*	4,4*	
20	Stabilizers raised							5,4	7,4	3,5	5,1	2,2	3,5							1,6	2,8	37'10"
	4 pt. outriggers down							7,7*	7,7*	6,7*	6,7*	5,8*	5,8*							4,2*	4,2*	
15	Stabilizers raised							5,1	7,1	3,3	4,8	2,1	3,4							1,4	2,4	39' 4"
	4 pt. outriggers down							8,0*	8,0*	6,8*	6,8*	5,8*	5,8*							4,2*	4,2*	
10	Stabilizers raised					7,2	9,5*	4,6	6,6	3,0	4,5	2,0	3,2	1,2	2,2					1,2	2,2	40' 1"
	4 pt. outriggers down					9,5*	9,5*	8,4*	8,4*	7,0*	7,0*	5,7	5,8*	4,3	4,4*					4,3*	4,3*	
5	Stabilizers raised	6,8*	6,8*	10,3	12,8*	6,2	8,9	4,0	6,0	2,7	4,2	1,8	3,0	1,1	2,1					1,1	2,1	40' 4"
	4 pt. outriggers down	6,8*	6,8*	12,8*	12,8*	11,2*	11,2*	8,8*	8,8*	7,0*	7,0*	5,5	5,6*	4,0*	4,0*					3,9*	3,9*	
0	Stabilizers raised	7,6*	7,6*	8,4	12,5	5,3	7,9	3,5	5,4	2,4	3,8	1,6	2,8							1,1	2,1	39'10"
	4 pt. outriggers down	7,6*	7,6*	16,5*	16,5*	11,7*	11,7*	8,8*	8,8*	6,9*	6,9*	5,2*	5,2*							3,3*	3,3*	
-5	Stabilizers raised	4,9*	4,9*	7,1	11,1	4,5	7,1	3,1	4,9	2,1	3,6	1,4	2,7							1,1	2,2	38' 8"
	4 pt. outriggers down	4,9*	4,9*	15,9*	15,9*	11,3*	11,3*	8,4*	8,4*	6,3*	6,3*	4,5*	4,5*							2,7*	2,7*	
-10	Stabilizers raised	5,9*	5,9*	6,5	10,4	4,1	6,7	2,8	4,7	1,9	3,4	1,4	2,6							1,3	2,4*	36'
	4 pt. outriggers down	5,9*	5,9*	13,6*	13,6*	9,8*	9,8*	7,2*	7,2*	5,1*	5,1*	3,0*	3,0*							2,4*	2,4*	

Height Can be slewed through 360° In longitudinal position of undercarriage Max. reach \* Limited by hydr. capacity

The lift capacities on the end of the stick extension without attachment are stated in lb x 1,000 and are valid on a firm, level supporting surface with blocked oscillating axle. These capacities can be slewed through 360° with the undercarriage in the transverse position. Capacities in the longitudinal position of the undercarriage (+/- 15°) are specified over the steering axle with the stabilizers raised and over the rigid axle with the stabilizers down. Indicated loads based on the ISO 10567 standard and do not exceed 75% of tipping or 87% of hydraulic capacity. The lift capacity of the unit is limited by its stability, the lifting capability of the hydraulic elements, or the maximum permissible lifting capacity of the load hook.



# LH 22 M – Equipment GTS16

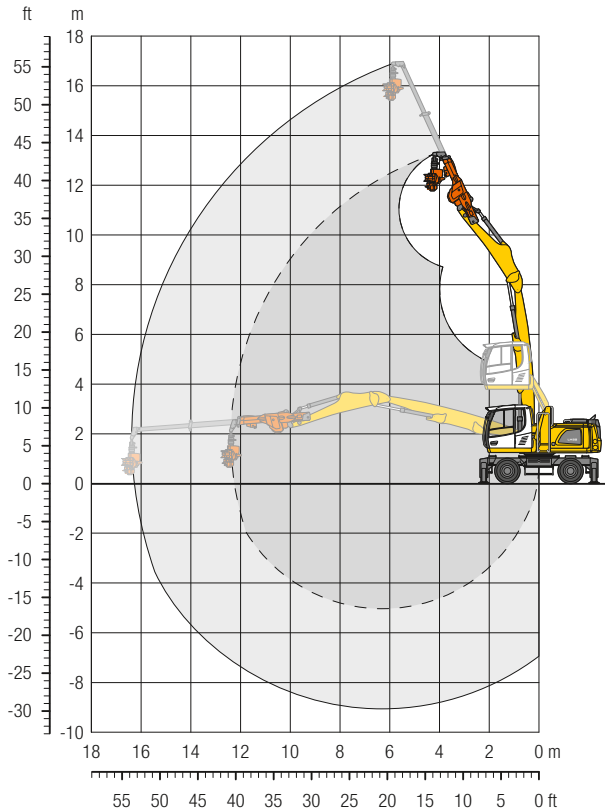

## Operating Weight

The operating weight includes the basic machine with 4 point outriggers, hydr. cab elevation, 8 solid tires plus intermediate rings, straight boom 19'8", stick with tipping kinematics 13'1", quick coupler SWA 48 LIKUFIX, telescope stage T 4000 with 13'1" and Woodcracker® CS510 crane.

Weight	52,300 lb
--------	-----------

ft in	Undercarriage	10 ft		15 ft		20 ft		25 ft		30 ft		35 ft		40 ft		45 ft		50 ft		ft in		
		Stabilizers raised	4 pt. outriggers down	Stabilizers raised	4 pt. outriggers down	Stabilizers raised	4 pt. outriggers down	Stabilizers raised	4 pt. outriggers down	Stabilizers raised	4 pt. outriggers down	Stabilizers raised	4 pt. outriggers down	Stabilizers raised	4 pt. outriggers down	Stabilizers raised	4 pt. outriggers down	Stabilizers raised	4 pt. outriggers down	Stabilizers raised	4 pt. outriggers down	ft in
55	Stabilizers raised			6,3*	6,3*															5,9*	5,9*	20'10"
	4 pt. outriggers down			6,3*	6,3*															5,9*	5,9*	20'10"
50	Stabilizers raised							3,7	4,2*											3,5	4,0*	30' 4"
	4 pt. outriggers down							4,2*	4,2*											4,0*	4,0*	30' 4"
45	Stabilizers raised									2,8	4,0*									2,2	3,2*	36' 8"
	4 pt. outriggers down									4,0*	4,0*									3,2*	3,2*	36' 8"
40	Stabilizers raised									3,3	4,6*	1,9	3,0							1,5	2,6	41' 6"
	4 pt. outriggers down									4,6*	4,6*	3,5*	3,5*							2,8*	2,8*	41' 6"
35	Stabilizers raised											2,3	3,4	1,1	2,1					1,1	2,0	45' 2"
	4 pt. outriggers down											4,2*	4,2*	2,6*	2,6*					2,5*	2,5*	45' 2"
30	Stabilizers raised											2,5	3,6	1,4	2,4					0,8	1,7	48' 1"
	4 pt. outriggers down											4,3*	4,3*	3,7*	3,7*					2,3*	2,3*	48' 1"
25	Stabilizers raised											2,5	3,6	1,5	2,5	0,6	1,5			0,6	1,4	50' 4"
	4 pt. outriggers down											4,3*	4,3*	3,9*	3,9*	2,4*	2,4*			2,2*	2,2*	50' 4"
20	Stabilizers raised											2,5	3,6	1,5	2,5	0,7	1,6			0,4	1,2	52'
	4 pt. outriggers down											4,3*	4,3*	3,9*	3,9*	3,2	3,3*			2,1*	2,1*	52'
15	Stabilizers raised											3,6	4,2*	2,4	3,5	1,5	2,4	0,7	1,5	0,3	1,1	53' 1"
	4 pt. outriggers down											4,2*	4,2*	4,4*	4,4*	3,9*	3,9*	3,1	3,3*	2,1*	2,1*	53' 1"
10	Stabilizers raised											3,4	4,4*	2,2	3,3	1,3	2,3	0,7	1,5	0,3	1,0	53' 8"
	4 pt. outriggers down											4,4*	4,4*	4,6*	4,6*	4,0*	4,0*	3,1	3,3*	2,1*	2,1*	53' 8"
5	Stabilizers raised							3,6*	3,6*	3,0	4,3	2,0	3,0	1,2	2,1	0,6	1,4	0,2	1,0	0,2	1,0	53'10"
	4 pt. outriggers down							3,6*	3,6*	5,0*	5,0*	4,7*	4,7*	3,9	4,0*	3,0	3,2*	2,0*	2,0*	2,0*	2,0*	53'10"
0	Stabilizers raised					2,6*	2,6*	3,9	4,8*	2,6	3,9	1,7	2,8	1,0	1,9	0,5	1,3	0,2	1,0	0,2	1,0	53' 6"
	4 pt. outriggers down					2,6*	2,6*	4,8*	4,8*	5,6*	5,6*	4,7*	4,7*	3,7	3,9*	2,9	2,9*	1,7*	1,7*	1,7*	1,7*	53' 6"
-5	Stabilizers raised			2,1*	2,1*	4,9	5,1*	3,3	4,8	2,2	3,5	1,4	2,5	8	1,7	0,4	1,2	0,2	1,0	0,2	1,0	52' 8"
	4 pt. outriggers down			2,1*	2,1*	5,1*	5,1*	6,8*	6,8*	5,7*	5,7*	4,6	4,7*	3,6	3,7*	2,5*	2,5*	1,3*	1,3*	1,3*	1,3*	52' 8"
-10	Stabilizers raised		8,1*	8,1*	6,0	8,7	4,0	5,9	2,7	4,2	1,8	3,0	1,2	2,2	0,7	1,6	0,4	1,2	0,3	1,0*	1,0*	51' 2"
	4 pt. outriggers down		8,1*	8,1*	9,6*	9,6*	8,8*	8,8*	6,9*	6,9*	5,6	5,6*	4,3	4,4*	3,3*	3,3*	1,7*	1,7*	1,0*	1,0*	1,0*	51' 2"

 **Height**  **Can be slewed through 360°**  **In longitudinal position of undercarriage**  **Max. reach** \* **Limited by hydr. capacity**

The lift capacities on the end of the extended telescope stage without attachment are stated in lb x 1,000 and are valid on a firm, level supporting surface with blocked oscillating axle. The maximum lift capacities of the telescopic stage from Westtech have to be considered separately ([www.westtech.at](http://www.westtech.at)). These capacities can be slewed through 360° with the undercarriage in the transverse position. Capacities in the longitudinal position of the undercarriage (+/- 15°) are specified over the steering axle with the stabilizers raised and over the rigid axle with the stabilizers down. Indicated loads based on the ISO 10567 standard and do not exceed 75% of tipping or 87% of hydraulic capacity. The lift capacity of the unit is limited by its stability, the lifting capability of the hydraulic elements, or the maximum permissible lifting capacity of the load hook.



# Technical Data

## LH 26 M Industry – Range Overview

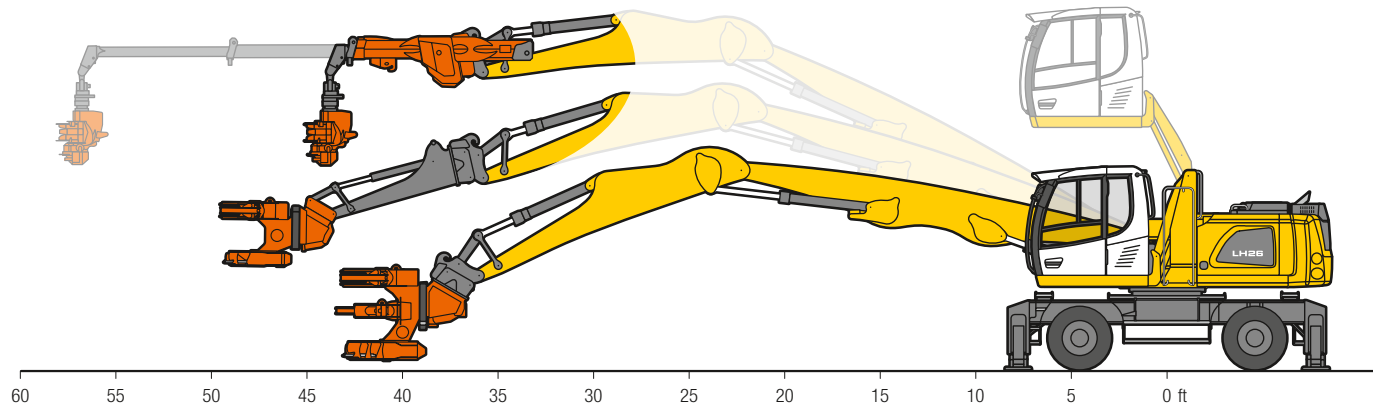

Operating weight*	lb	approx. 53,400 – 54,000		
Engine output (SAE J1349/ISO 9249)	kW/HP	115/154		
Emission stage	Stage	V	IIIA (compliant)	Tier 4f
Reach with direct mounting Woodcracker®	ft in	up to 41'		
Reach with stick extension and Woodcracker®	ft in	up to 47'7"		
Reach with telescope stage and Woodcracker®	ft in	up to 57'5"		

\* without attachment



# LH 26 M – Dimensions

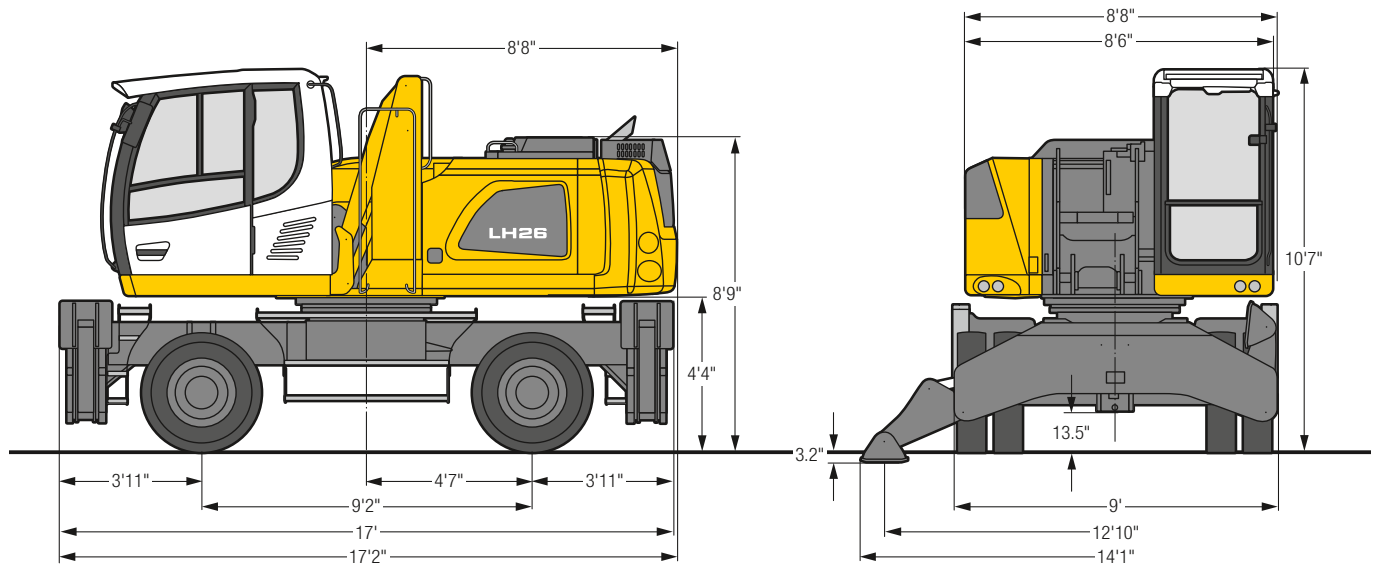

# LH 26 M – Choice of Cab Elevation

**Cab Elevation LHC (Hydraulic Elevation)**

**Cab Elevation LHC (30° Tilt Function as an Option)**

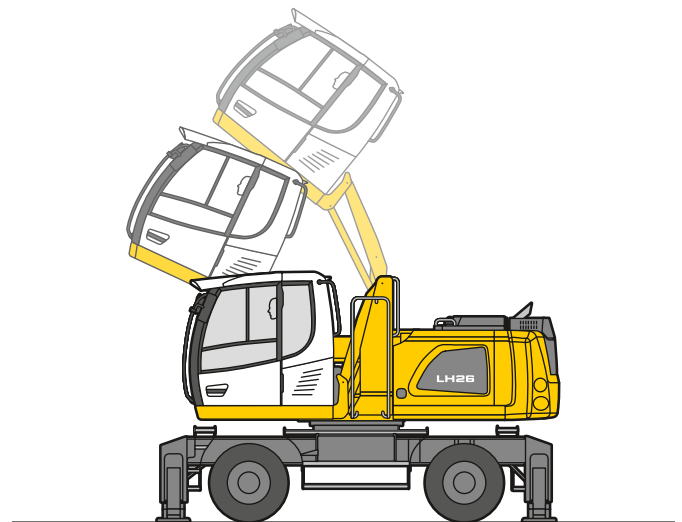
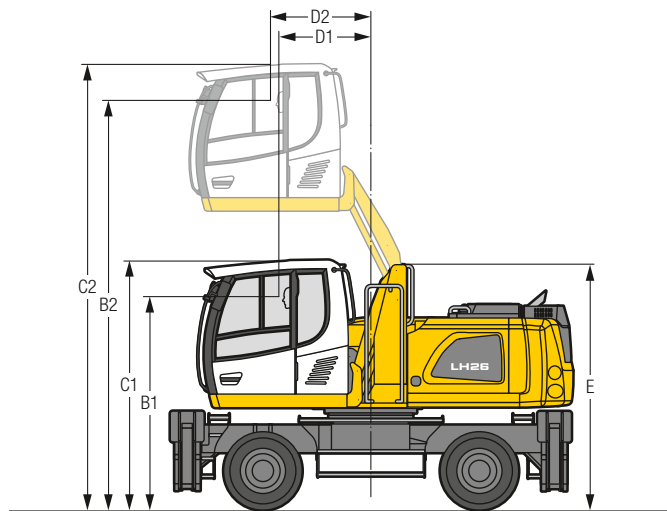

Increase type	LHC 255
B1	9' 1"
B2	17' 5"
C1	10' 7"
C2	19'
D1	3'11"
D2	4' 3"
E	10' 5"

The hydraulically adjustable cab allows the driver, that he can choose his field of view freely and at any time within the stroke.

**Tires 10.00-20**

# LH 26 M – Equipment GK11

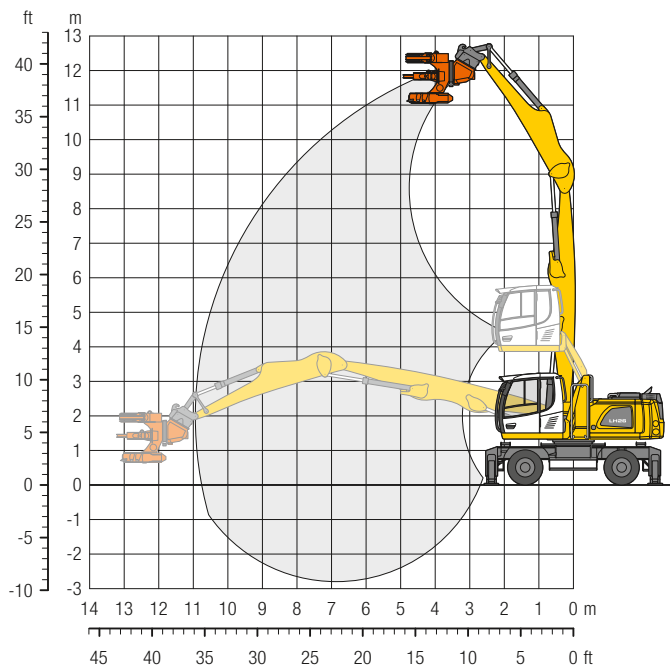

## Operating Weight

The operating weight includes the basic machine with 4 point outriggers, hydr. cab elevation, 8 solid tires plus intermediate rings, straight boom 21'8", stick with tipping kinematics 14'9", quick coupler SWA 48 LIKUFIX and Woodcracker® C350.

Weight 58,300 lb

ft in	Undercarriage	10 ft		15 ft		20 ft		25 ft		30 ft		35 ft		40 ft		45 ft		50 ft		55 ft		ft in		
		Stabilizers raised	4 pt. outriggers down	Stabilizers raised	4 pt. outriggers down	Stabilizers raised	4 pt. outriggers down	Stabilizers raised	4 pt. outriggers down	Stabilizers raised	4 pt. outriggers down	Stabilizers raised	4 pt. outriggers down	Stabilizers raised	4 pt. outriggers down	Stabilizers raised	4 pt. outriggers down	Stabilizers raised	4 pt. outriggers down	Stabilizers raised	4 pt. outriggers down	Stabilizers raised	4 pt. outriggers down	
40	Stabilizers raised					9,6	12,0*															13,5*	13,5*	
	4 pt. outriggers down																					13,5*	13,5*	
35	Stabilizers raised					12,0*	12,0*															7,7	10,1*	
	4 pt. outriggers down																					10,1*	10,1*	
30	Stabilizers raised					9,8	13,4	6,4	8,9													5,1	7,2	
	4 pt. outriggers down					13,8*	13,8*	11,4*	11,4*													8,9*	8,9*	
25	Stabilizers raised					9,7	13,3	6,4	8,9	4,3	6,2											3,8	5,6	
	4 pt. outriggers down					14,0*	14,0*	12,1*	12,1*	9,9	10,1*											8,4*	8,4*	
20	Stabilizers raised			15,4	15,7*	9,4	12,9	6,2	8,7	4,2	6,1											3,1	4,7	
	4 pt. outriggers down			15,7*	15,7*	14,6*	14,6*	12,3*	12,3*	9,8	10,5*											7,8	8,3*	
15	Stabilizers raised	14,5*	14,5*	14,2	19,7*	8,7	12,2	5,8	8,3	4,0	5,9	2,8	4,3									2,7	4,2	
	4 pt. outriggers down	14,5*	14,5*	19,7*	19,7*	15,5*	15,5*	12,7*	12,7*	9,6	10,5*	7,3	8,6*									7,1	8,3*	
10	Stabilizers raised	23,5	35,2*	12,4	18,0	7,8	11,2	5,3	7,8	3,8	5,6	2,7	4,2									2,4	3,9	
	4 pt. outriggers down	35,2*	35,2*	22,4*	22,4*	16,5*	16,5*	12,6	13,0*	9,3	10,5*	7,1	8,4*									6,7	7,7*	
5	Stabilizers raised	3,4*	3,4*	10,7	16,1	7,0	10,3	4,9	7,3	3,5	5,4	2,5	4,1									2,3	3,8	
	4 pt. outriggers down	3,4*	3,4*	23,6*	23,6*	16,9*	16,9*	12,1	13,0*	9,0	10,3*	7,0	7,9*									6,5	7,0*	
0	Stabilizers raised	3,8*	3,8*	9,7	14,9	6,4	9,7	4,5	6,9	3,3	5,1	2,4	4,0									2,3	3,8	
	4 pt. outriggers down	3,8*	3,8*	16,5*	16,5*	16,3*	16,3*	11,7	12,4*	8,8	9,5*	6,8*	6,8*									6,2*	6,2*	
-5	Stabilizers raised			9,3	14,5	6,0	9,3	4,3	6,6	3,2	5,0											2,5	4,0	
	4 pt. outriggers down			14,8*	14,8*	14,2*	14,2*	10,8*	10,8*	8,0*	8,0*											5,3*	5,3*	
-10	Stabilizers raised					6,0	9,2	4,2	6,6														3,9	6,2
	4 pt. outriggers down					10,8*	10,8*	8,2*	8,2*														7,6*	7,6*

Height Can be slewed through 360° In longitudinal position of undercarriage Max. reach \* Limited by hydr. capacity

The lift capacities on the stick end without attachment are stated in lb x 1,000 and are valid on a firm, level supporting surface with blocked oscillating axle. These capacities can be slewed through 360° with the undercarriage in the transverse position. Capacities in the longitudinal position of the undercarriage (+/- 15°) are specified over the steering axle with the stabilizers raised and over the rigid axle with the stabilizers down. Indicated loads based on the ISO 10567 standard and do not exceed 75% of tipping or 87% of hydraulic capacity. The lift capacity of the unit is limited by its stability, the lifting capability of the hydraulic elements, or the maximum permissible lifting capacity of the load hook.



# LH 26 M – Equipment GSV13

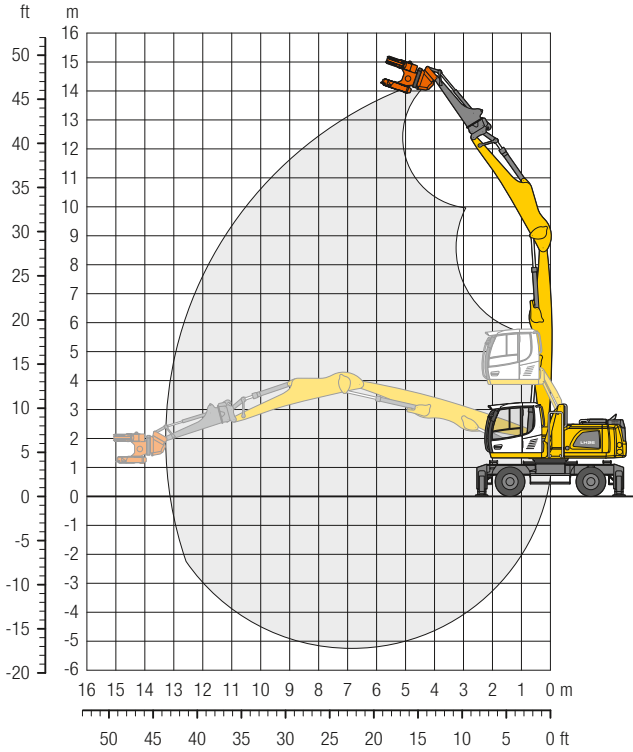

## Operating Weight

The operating weight includes the basic machine with 4 point outriggers, hydr. cab elevation, 8 solid tires plus intermediate rings, straight boom 21'8", stick with tipping kinematics 14'9", quick coupler SWA 48 LIKUFIX, stick extension 7'5" and Woodcracker® C250.

Weight 57,900 lb

ft in	Undercarriage	10 ft	15 ft	20 ft	25 ft	30 ft	35 ft	40 ft	45 ft	50 ft	55 ft	ft in	
55	Stabilizers raised 4 pt. outriggers down												
50	Stabilizers raised 4 pt. outriggers down												
45	Stabilizers raised 4 pt. outriggers down											8,9" 8,9"	8,9" 8,9"
40	Stabilizers raised 4 pt. outriggers down				6,7 8,1*	8,1*						5,5 6,8*	6,8" 6,8"
35	Stabilizers raised 4 pt. outriggers down				7,2 9,2*	9,2*	4,7 7,5*	6,6 7,5*				3,7 5,9*	5,4 5,9*
30	Stabilizers raised 4 pt. outriggers down				7,3 9,5*	9,5*	4,8 8,6*	6,8 8,6*	3,1 6,5*	4,7 6,5*		2,7 5,4*	4,2 5,4*
25	Stabilizers raised 4 pt. outriggers down				7,2 9,7*	9,7*	4,8 8,9*	6,8 8,9*	3,2 7,8	4,8 7,9*		2,1 5,2*	3,5 5,2*
20	Stabilizers raised 4 pt. outriggers down				7,0 10,1*	9,5 10,1*	4,6 9,1*	6,6 9,1*	3,1 7,7	4,7 8,0*	2,0 5,8	3,3 6,3*	1,7 5,1*
15	Stabilizers raised 4 pt. outriggers down			9,6* 9,6*	9,6* 9,6*	6,5 10,8*	9,1 10,8*	4,3 9,3*	6,3 9,3*	2,9 7,5	4,5 8,1*	1,9 5,7	3,2 6,9*
10	Stabilizers raised 4 pt. outriggers down		8,2* 8,2*	8,2* 8,2*	9,1 11,9*	11,9* 11,9*	5,9 11,5*	8,4 11,5*	3,9 9,6	5,9 9,6*	2,7 7,2	4,2 8,2*	1,7 5,5
5	Stabilizers raised 4 pt. outriggers down	14,3* 14,3*	14,3* 14,3*	12,7 18,6*	18,4* 18,6*	7,8 15,3*	11,2* 15,3*	5,1 12,1*	7,6 12,1*	3,5 9,1	5,4 9,9*	2,4 6,9	3,9 8,1*
0	Stabilizers raised 4 pt. outriggers down	7,0* 7,0*	7,0* 7,0*	10,4 22,4*	15,8* 22,4*	6,6 16,0*	10,0* 16,0*	4,5 11,8	6,9 12,3*	3,1 8,7	5,0 9,8*	2,1 6,6	3,7 7,8*
-5	Stabilizers raised 4 pt. outriggers down	5,4* 5,4*	5,4* 5,4*	8,8 20,3*	14,1* 20,3*	5,7 15,6*	9,0* 15,6*	3,9 11,1	6,3 11,9*	2,7 8,3	4,6 9,2*	1,9 6,4	3,5 7,1*
-10	Stabilizers raised 4 pt. outriggers down	6,6* 6,6*	6,6* 6,6*	8,1 15,6*	13,2* 15,6*	5,2 14,0*	8,4* 14,0*	3,5 10,6*	5,9 10,6*	2,5 8,0	4,4 8,1*	1,8 5,8*	3,3 5,8*
												1,4 3,8*	2,7 3,8*

**Height** **Can be slewed through 360°** **In longitudinal position of undercarriage** **Max. reach** \* Limited by hydr. capacity

The lift capacities on the end of the stick extension without attachment are stated in lb x 1,000 and are valid on a firm, level supporting surface with blocked oscillating axle. These capacities can be slewed through 360° with the undercarriage in the transverse position. Capacities in the longitudinal position of the undercarriage (+/- 15°) are specified over the steering axle with the stabilizers raised and over the rigid axle with the stabilizers down. Indicated loads based on the ISO 10567 standard and do not exceed 75% of tipping or 87% of hydraulic capacity. The lift capacity of the unit is limited by its stability, the lifting capability of the hydraulic elements, or the maximum permissible lifting capacity of the load hook.

# LH 26 M – Equipment GTS17

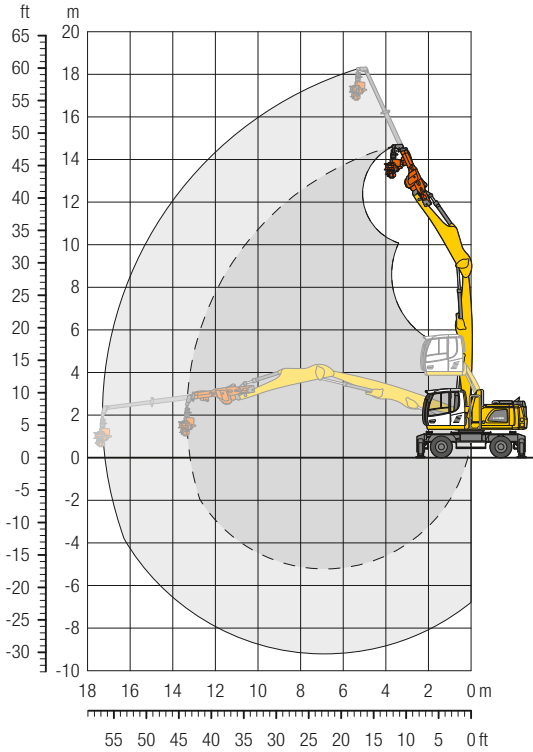

## Operating Weight

The operating weight includes the basic machine with 4 point outriggers, hydr. cab elevation, 8 solid tires plus intermediate rings, straight boom 21'8", stick with tipping kinematics 14'9", quick coupler SWA 48 LIKUFIX, telescope stage T 4000 with 13'1" and Woodcracker® CS510 crane.

Weight	57,800 lb
--------	-----------

ft in	Undercarriage	10 ft		15 ft		20 ft		25 ft		30 ft		35 ft		40 ft		45 ft		50 ft		55 ft		ft in				
		Stabilizers raised 4 pt. outriggers down	Stabilizers raised 4 pt. outriggers down	Stabilizers raised 4 pt. outriggers down	Stabilizers raised 4 pt. outriggers down	Stabilizers raised 4 pt. outriggers down	Stabilizers raised 4 pt. outriggers down	Stabilizers raised 4 pt. outriggers down	Stabilizers raised 4 pt. outriggers down	Stabilizers raised 4 pt. outriggers down	Stabilizers raised 4 pt. outriggers down	Stabilizers raised 4 pt. outriggers down	Stabilizers raised 4 pt. outriggers down	Stabilizers raised 4 pt. outriggers down	Stabilizers raised 4 pt. outriggers down	Stabilizers raised 4 pt. outriggers down	Stabilizers raised 4 pt. outriggers down	Stabilizers raised 4 pt. outriggers down	Stabilizers raised 4 pt. outriggers down	Stabilizers raised 4 pt. outriggers down	Stabilizers raised 4 pt. outriggers down	Stabilizers raised 4 pt. outriggers down	Stabilizers raised 4 pt. outriggers down	ft in		
55	Stabilizers raised 4 pt. outriggers down					6,5*	6,5*																5,2*	5,2*	28' 8"	
50	Stabilizers raised 4 pt. outriggers down							6,0*	6,0*	3,9	4,6*												5,2*	5,2*	36'	
45	Stabilizers raised 4 pt. outriggers down									4,5	5,5*	4,2*	4,2*	2,8	4,2*								2,4	3,6*	41' 5"	
40	Stabilizers raised 4 pt. outriggers down									4,8	5,7*	3,2	4,6	1,9	3,1								1,8	2,9	45' 7"	
35	Stabilizers raised 4 pt. outriggers down									5,7*	5,7*	5,1*	5,1*	3,5*	3,5*								3,2*	3,2*	49'	
30	Stabilizers raised 4 pt. outriggers down													3,4	4,8	2,2	3,4						1,3	2,4	51' 7"	
25	Stabilizers raised 4 pt. outriggers down													5,4*	5,4*	4,5*	4,5*						3,0*	3,0*	53' 7"	
20	Stabilizers raised 4 pt. outriggers down													3,5	4,9	2,3	3,5	1,3	2,3				1,0	2,0	55' 1"	
15	Stabilizers raised 4 pt. outriggers down													5,5*	5,5*	5,0*	5,0*	3,6*	3,6*				2,8*	2,8*	56' 1"	
10	Stabilizers raised 4 pt. outriggers down													3,4	4,6	2,1	3,3	1,3	2,3	0,6	1,5	0,5	1,4	1,4	56' 8"	
5	Stabilizers raised 4 pt. outriggers down													4,4	5,8*	3,0	4,3	1,9	3,1	1,2	2,2	0,6	1,5	0,4	1,3	56' 10"
0	Stabilizers raised 4 pt. outriggers down													5,8*	5,8*	6,3*	6,3*	5,3	5,6*	4,1	5,0*	3,2	3,7*	2,7*	2,7*	56' 5"
-5	Stabilizers raised 4 pt. outriggers down													3,9	5,5	2,6	4,0	1,7	2,9	1,0	2,0	0,5	1,4	0,3	1,2	55' 7"
-10	Stabilizers raised 4 pt. outriggers down													4,6*	4,6*	4,9	6,8*	3,4	5,0	2,3	3,6	1,5	2,6	0,9	1,9	54' 4"
														4,6*	4,6*	4,9	6,8*	3,4	5,0	2,3	3,6	1,5	2,6	0,9	1,9	
														5,3*	5,3*	6,1	8,2*	4,1	6,1	2,8	4,4	1,9	3,2	1,2	2,4	
														5,3*	5,3*	6,1	8,2*	4,1	6,1	2,8	4,4	1,9	3,2	1,2	2,4	
														11,6	17,2	7,3	10,8	4,9	7,4	3,4	5,3	2,3	3,9	1,6	2,9	
														21,2*	21,2*	15,4*	15,4*	11,9*	11,9*	9,1	9,6*	6,9	7,9*	5,4	6,5*	

Height Can be slewed through 360° In longitudinal position of undercarriage Max. reach \* Limited by hydr. capacity

The lift capacities on the end of the extended telescope stage without attachment are stated in lb x 1,000 and are valid on a firm, level supporting surface with blocked oscillating axle. The maximum lift capacities of the telescopic stage from Westtech have to be considered separately ([www.westtech.at](http://www.westtech.at)). These capacities can be slewed through 360° with the undercarriage in the transverse position. Capacities in the longitudinal position of the undercarriage (+/- 15°) are specified over the steering axle with the stabilizers raised and over the rigid axle with the stabilizers down. Indicated loads based on the ISO 10567 standard and do not exceed 75% of tipping or 87% of hydraulic capacity. The lift capacity of the unit is limited by its stability, the lifting capability of the hydraulic elements, or the maximum permissible lifting capacity of the load hook.



# Technical Data

## LH 30 M Industry – Range Overview

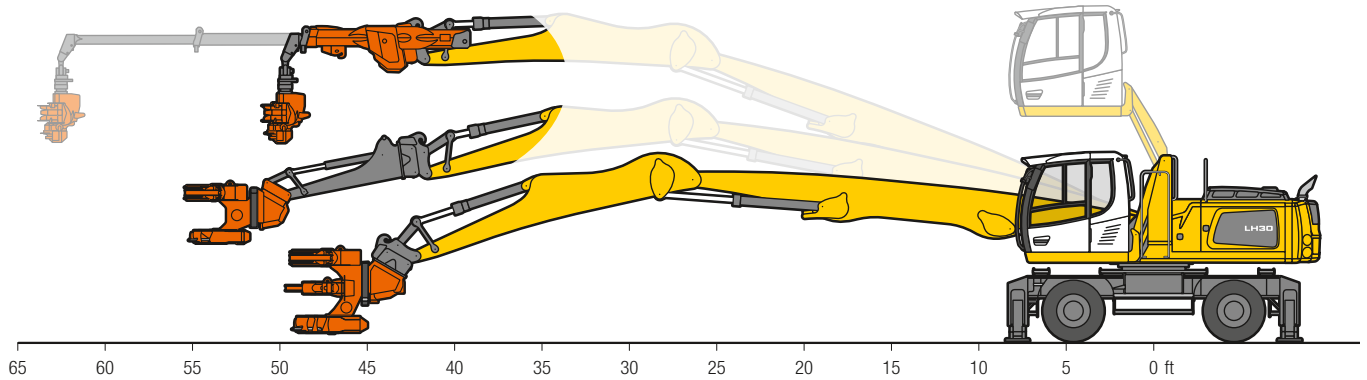

Operating weight*	lb	approx. 58,400 – 64,200		
Engine output (SAE J1349/ISO 9249)	kW/HP	140/188		
Emission stage	Stage	V	IIIA (compliant)	Tier 4f
Reach with direct mounting Woodcracker®	ft in	up to 47'7"		
Reach with stick extension and Woodcracker®	ft in	up to 54'2"		
Reach with telescope stage and Woodcracker®	ft in	up to 62'4"		

\* without attachment

# LH 30 M – Dimensions

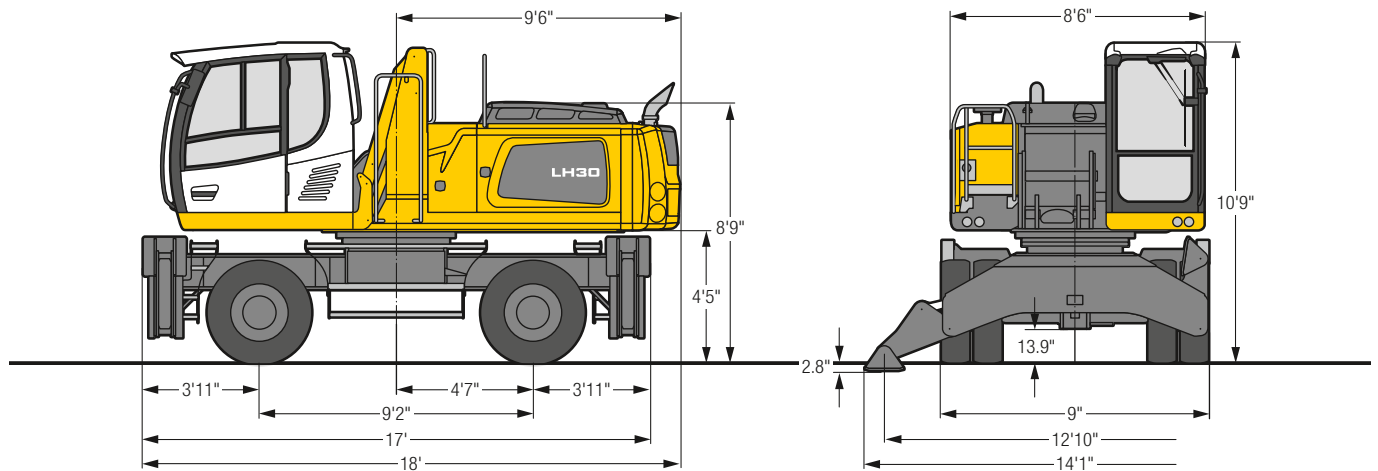

\* 9'11" with heavy counterweight

# LH 30 M – Choice of Cab Elevation

## Cab Elevation LHC (Hydraulic Elevation)

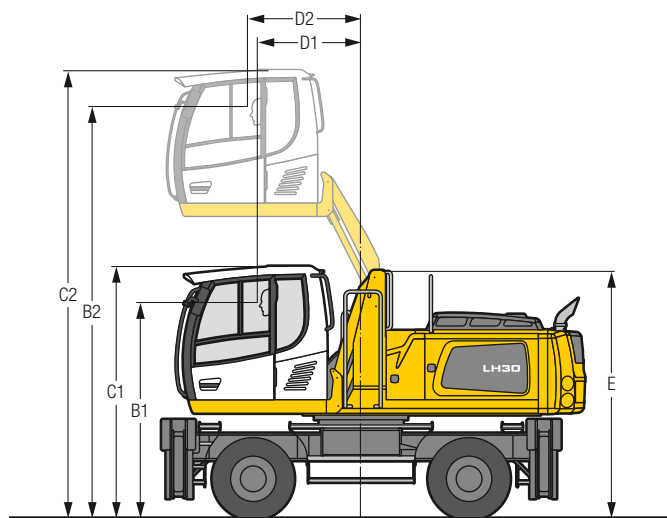

## Cab Elevation LHC (30° Tilt Function as an Option)

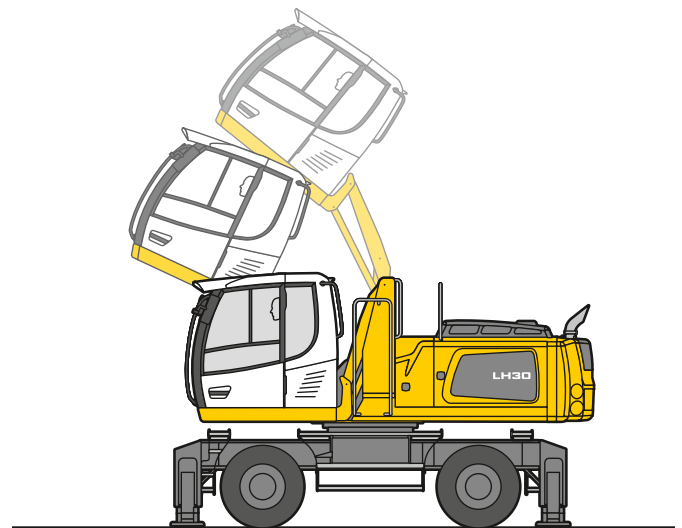

Increase type	LHC 255
B1	9' 3"
B2	17' 7"
C1	10' 9"
C2	19' 1"
D1	4' 5"
D2	4'10"
E	10' 7"

The hydraulically adjustable cab allows the driver, that he can choose his field of view freely and at any time within the stroke.

Tires 10.00-20



# LH 30 M – Equipment GK13 with Heavy Counterweight

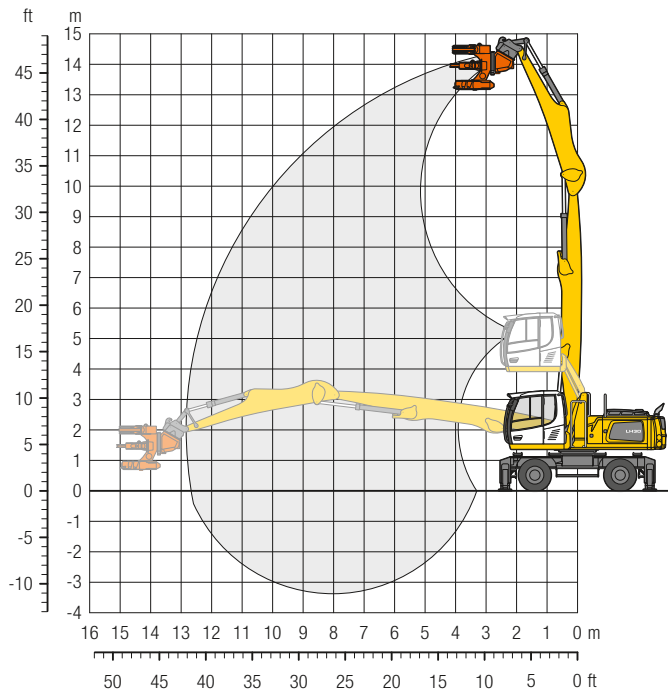

## Operating Weight

The operating weight includes the basic machine with 4 point outriggers, hydr. cab elevation, 8 solid tires plus intermediate rings, straight boom 25'7", stick with tipping kinematics 16'5", quick coupler SWA 48 LIKUFIX and Woodcracker® C350.

Weight 68,900 lb

ft in	10 ft	15 ft	20 ft	25 ft	30 ft	35 ft	40 ft	45 ft	50 ft	55 ft	60 ft	ft in
<b>55</b>												
<b>50</b>												
<b>45</b>												12,8* 12,8*
<b>40</b>												12,8* 12,8*
<b>35</b>												18' 4"
<b>30</b>												8,0 9,9*
<b>25</b>												9,9* 9,9*
<b>20</b>												26' 7"
<b>15</b>												5,6 7,7
<b>10</b>												8,6* 8,6*
<b>5</b>												4,3 6,2
<b>0</b>												7,9* 7,9*
<b>-5</b>												35'11"
<b>-10</b>												3,5 5,2
												7,6* 7,6*
												38' 8"
												3,0 4,6
												40'10"
												7,4* 7,4*
												2,7 4,2
												42' 1"
												6,9* 6,9*
												2,5 4,0
												42'10"
												6,2* 6,2*
												2,4 3,9
												42'11"
												5,4* 5,4*
												2,5 3,9
												42' 5"
												4,6* 4,6*
												2,6 4,1*
												40' 7"
												4,1* 4,1*
												3,4 5,0*
												35'
												5,0* 5,0*

**Height** **Can be slewed through 360°** **In longitudinal position of undercarriage** **Max. reach** \* Limited by hydr. capacity

The lift capacities on the stick end without attachment are stated in lb x 1,000 and are valid on a firm, level supporting surface with blocked oscillating axle. These capacities can be slewed through 360° with the undercarriage in the transverse position. Capacities in the longitudinal position of the undercarriage (+/- 15°) are specified over the steering axle with the stabilizers raised and over the rigid axle with the stabilizers down. Indicated loads based on the ISO 10567 standard and do not exceed 75% of tipping or 87% of hydraulic capacity. The lift capacity of the unit is limited by its stability, the lifting capability of the hydraulic elements, or the maximum permissible lifting capacity of the load hook.

# LH 30 M – Equipment GSV15 with Heavy Counterweight

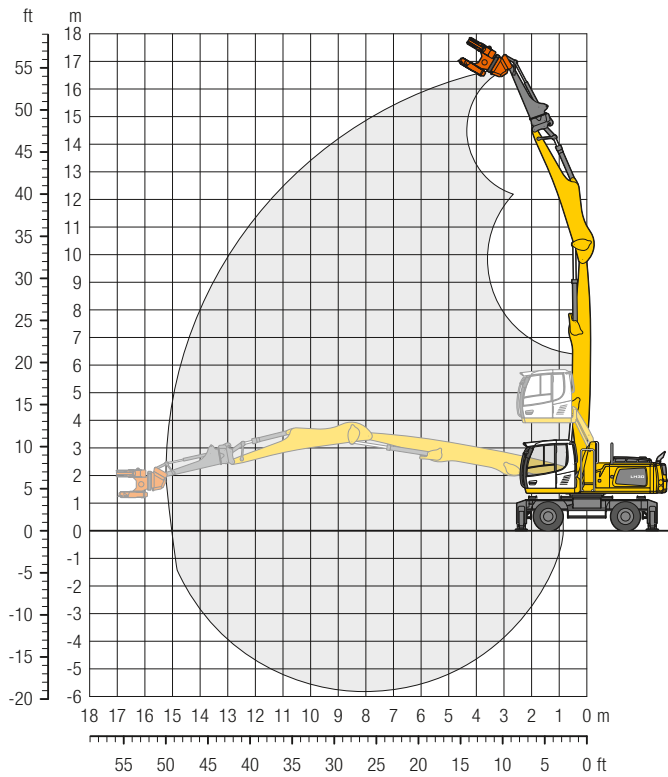

## Operating Weight

The operating weight includes the basic machine with 4 point outriggers, hydr. cab elevation, 8 solid tires plus intermediate rings, straight boom 25'7", stick with tipping kinematics 16'5", quick coupler SWA 48 LIKUFIX, stick extension 7'5" and Woodcracker® C250.

Weight	68,600 lb
--------	-----------

ft in	10 ft	15 ft	20 ft	25 ft	30 ft	35 ft	40 ft	45 ft	50 ft	55 ft	60 ft	ft in		
<b>55</b>												16,8"	16,8"	<b>9' 7"</b>
												16,8"	16,8"	
<b>50</b>												8,7"	8,7"	<b>23'11"</b>
												11,7"	11,7"	
<b>45</b>												10,1"	11,1"	<b>31' 6"</b>
												11,1"	11,1"	
<b>40</b>												10,7"	11,5"	<b>36'11"</b>
												7,3"	9,8"	
<b>35</b>												10,9"	11,2"	<b>40'11"</b>
												7,5"	9,8"	
<b>30</b>												11,2"	11,2"	<b>44'</b>
												9,8"	9,8"	
<b>25</b>												10,8"	11,1"	<b>46' 5"</b>
												7,5"	9,8"	
<b>20</b>												11,1"	11,1"	<b>48' 1"</b>
												9,8"	9,8"	
<b>15</b>												10,6"	11,3"	<b>49' 2"</b>
												7,3"	9,8"	
<b>10</b>												11,3"	11,3"	<b>49'10"</b>
												9,9"	9,9"	
<b>5</b>												10,0"	11,8"	<b>49'11"</b>
												7,0"	9,4"	
<b>0</b>												11,8"	11,8"	<b>49' 5"</b>
												10,1"	10,1"	
<b>-5</b>												12,3"	12,3"	<b>48' 6"</b>
												9,3"	12,4"	
<b>-10</b>												10,4"	10,4"	<b>45' 5"</b>
												8,9"	8,9"	

Height Can be slewed through 360° In longitudinal position of undercarriage Max. reach \* Limited by hydr. capacity

The lift capacities on the end of the stick extension without attachment are stated in lb x 1,000 and are valid on a firm, level supporting surface with blocked oscillating axle. These capacities can be slewed through 360° with the undercarriage in the transverse position. Capacities in the longitudinal position of the undercarriage (+/- 15°) are specified over the steering axle with the stabilizers raised and over the rigid axle with the stabilizers down. Indicated loads based on the ISO 10567 standard and do not exceed 75% of tipping or 87% of hydraulic capacity. The lift capacity of the unit is limited by its stability, the lifting capability of the hydraulic elements, or the maximum permissible lifting capacity of the load hook.



# LH 30 M – Equipment GTS19 with Heavy Counterweight

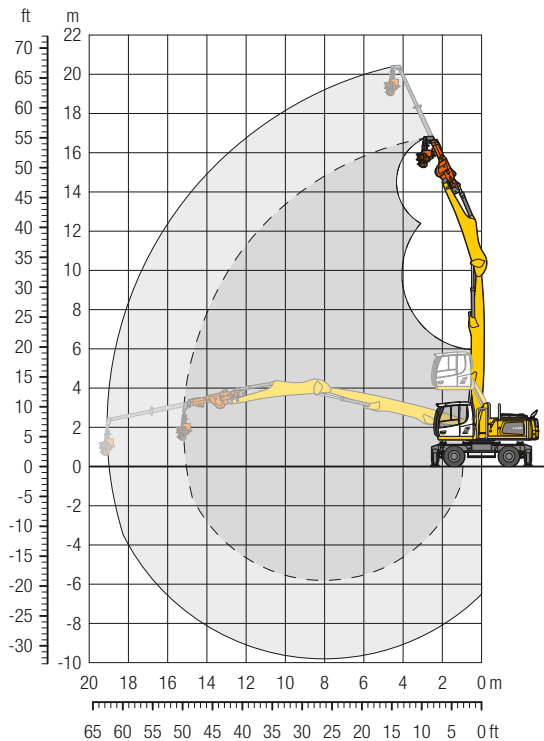

## Operating Weight

The operating weight includes the basic machine with 4 point outriggers, hydr. cab elevation, 8 solid tires plus intermediate rings, straight boom 25'7", stick with tipping kinematics 16'5", quick coupler SWA 48 LIKUFIX, telescope stage T 4000 with 13'1" and Woodcracker® CS510 crane.

Weight	68,500 lb
--------	-----------

ft in	Undercarriage	10 ft	15 ft	20 ft	25 ft	30 ft	35 ft	40 ft	45 ft	50 ft	55 ft	60 ft	ft in	
65	Stabilizers raised 4 pt. outriggers down			9,9* 9,9*									7,8* 7,8*	
60	Stabilizers raised 4 pt. outriggers down					7,4* 7,4*							5,3* 5,3*	
55	Stabilizers raised 4 pt. outriggers down						6,1 7,1*	3,8 4,6*					3,7 4,2*	
50	Stabilizers raised 4 pt. outriggers down						6,8 7,6*	4,7 6,6*	6,4 6,6*	4,4* 4,4*			2,6 3,6*	
45	Stabilizers raised 4 pt. outriggers down							5,2 6,7*	6,7* 6,1*	3,5 5,0	2,0 3,3		2,0 3,2*	
40	Stabilizers raised 4 pt. outriggers down							5,4 6,6*	6,6* 6,0*	3,8 6,0*	5,3 5,4*		1,5 2,9*	
35	Stabilizers raised 4 pt. outriggers down							5,5 6,5*	6,5* 6,0*	3,9 6,0*	5,4 5,4*		1,2 2,7*	
30	Stabilizers raised 4 pt. outriggers down							5,5 6,5*	6,5* 6,0*	4,0 6,0*	5,4 4,8*		0,9 2,6*	
25	Stabilizers raised 4 pt. outriggers down							5,4 6,6*	6,6* 6,0*	3,9 6,0*	5,4 4,8*	0,9 3,2*	1,9 2,5*	
20	Stabilizers raised 4 pt. outriggers down							5,2 6,7*	6,7* 6,1*	3,8 6,1*	5,2 5,5*		0,6 3,7	
15	Stabilizers raised 4 pt. outriggers down							6,8* 6,8*	6,8* 6,9*	4,9 6,2*	3,5 6,2*		1,9 2,4*	
10	Stabilizers raised 4 pt. outriggers down							6,3 7,3*	7,3* 7,1*	4,5 7,1*	3,2 6,3*		1,8 2,4*	
5	Stabilizers raised 4 pt. outriggers down					6,6* 6,6*	6,6* 8,4*	5,7 8,4*	7,7 8,4*	4,1 7,3*	2,9 6,3*	2,0 5,5*		1,7 2,2*
0	Stabilizers raised 4 pt. outriggers down		2,2* 2,2*	2,2* 6,3*	6,3* 6,3*	6,9 9,1*	9,1* 8,7*	5,0 8,7*	6,9 8,7*	3,6 7,4*	5,2 7,4*	2,6 6,3*		1,8 1,7*
-5	Stabilizers raised 4 pt. outriggers down		9,1* 9,1*	9,1* 12,2*	8,2 12,2*	11,4 10,6*	5,9 10,6*	8,3 8,8*	4,3 8,8*	6,2 7,4*	3,1 7,4*	4,7 6,2*		1,3 1,3*
-10	Stabilizers raised 4 pt. outriggers down	14,7 24,1*	21,5 24,1*	9,7 17,3*	13,9 17,3*	6,8 13,3*	9,8 13,3*	4,9 10,6*	7,3 10,6*	3,6 8,7*	5,5 8,7*	2,6 7,2*		1,3 1,3*

**Height** **Can be slewed through 360°** **In longitudinal position of undercarriage** **Max. reach** \* **Limited by hydr. capacity**

The lift capacities on the end of the extended telescope stage without attachment are stated in lb x 1,000 and are valid on a firm, level supporting surface with blocked oscillating axle. The maximum lift capacities of the telescopic stage from Westtech have to be considered separately ([www.westtech.at](http://www.westtech.at)). These capacities can be slewed through 360° with the undercarriage in the transverse position. Capacities in the longitudinal position of the undercarriage (+/- 15°) are specified over the steering axle with the stabilizers raised and over the rigid axle with the stabilizers down. Indicated loads based on the ISO 10567 standard and do not exceed 75% of tipping or 87% of hydraulic capacity. The lift capacity of the unit is limited by its stability, the lifting capability of the hydraulic elements, or the maximum permissible lifting capacity of the load hook.

# Technical Data

## LH 30 C Industry – Range Overview

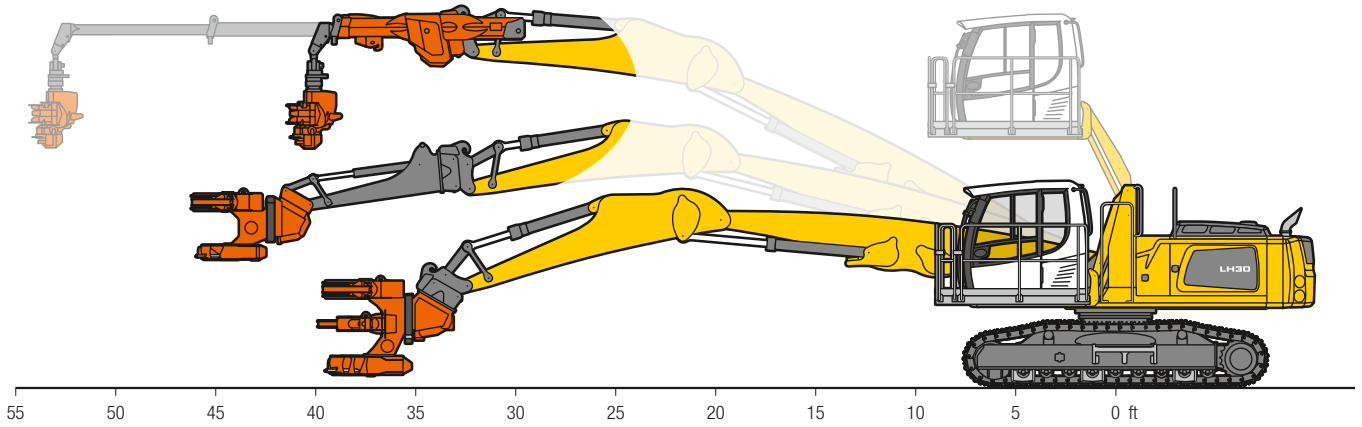

Operating weight*	lb	approx. 59,700 – 66,600		
Engine output (SAE J1349/ISO 9249)	kW/HP	140/188		
Emission stage	Stage	V	IIIA (compliant)	Tier 4f
Reach with direct mounting Woodcracker®	ft in	up to 37'9"		
Reach with stick extension and Woodcracker®	ft in	up to 44'3"		
Reach with telescope stage and Woodcracker®	ft in	up to 52'6"		

\* without attachment

# LH 30 C LC – Dimensions

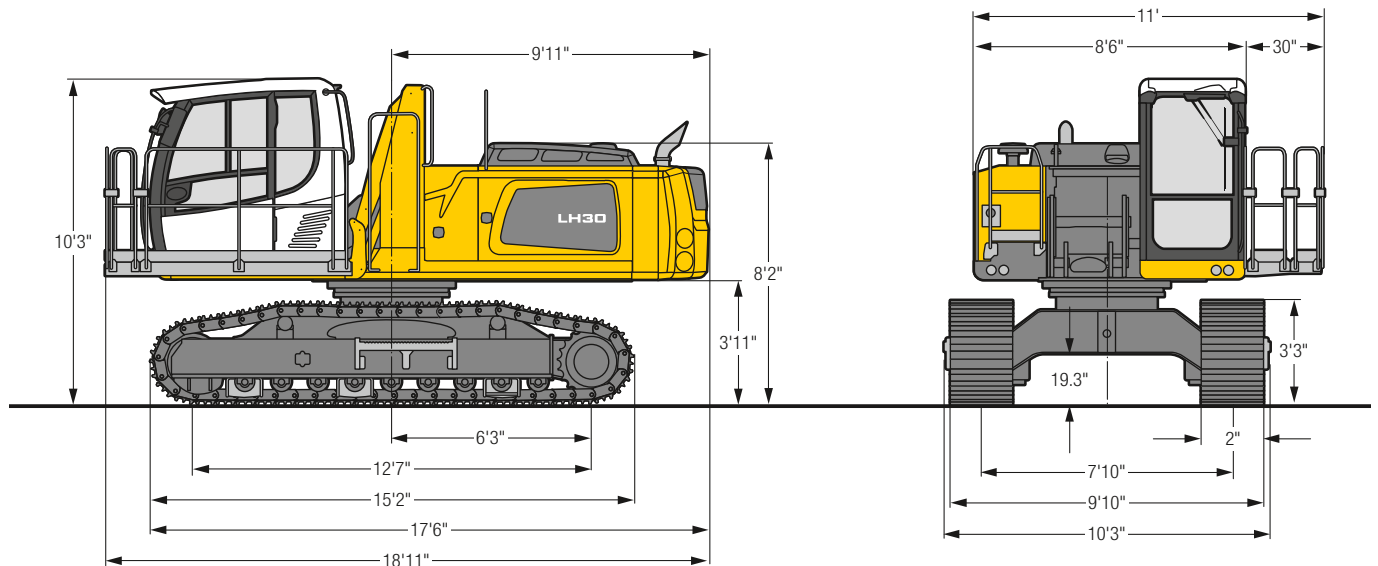

# LH 30 C LC – Choice of Cab Elevation

**Cab Elevation LHC  
(Hydraulic Elevation)**

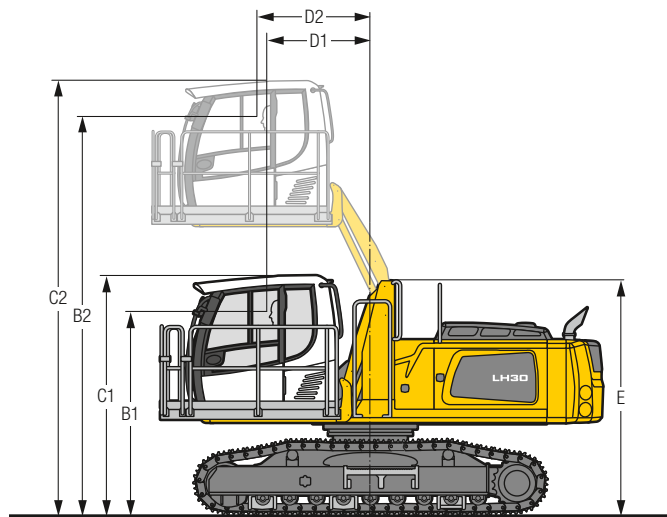

**Cab Elevation LHC  
(30° Tilt Function as an Option)**

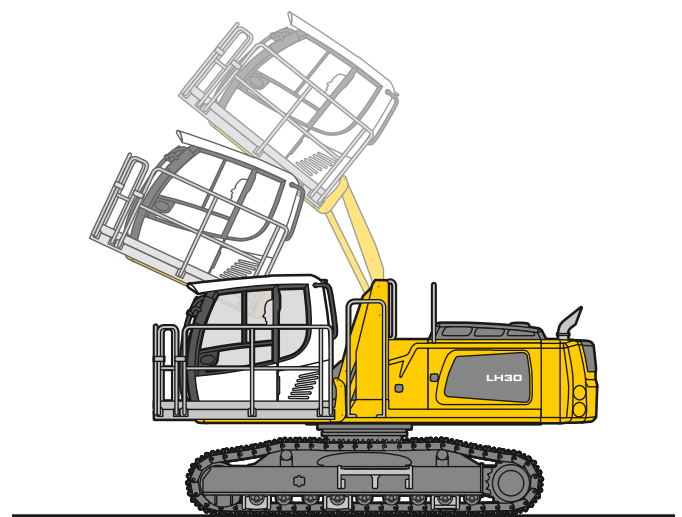

Increase type	LHC 255
B1	8' 8"
B2	17' 1"
C1	10' 3"
C2	18' 7"
D1	4' 5"
D2	4'10"
E	10'

The hydraulically adjustable cab allows the driver, that he can choose his field of view freely and at any time within the stroke.



# LH 30 C LC – Equipment GK10

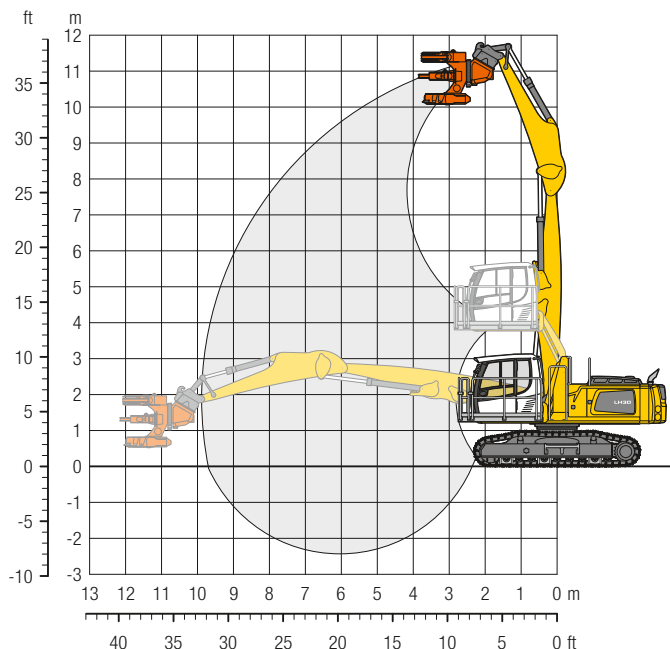

## Operating Weight and Ground Pressure

The operating weight includes the basic machine with hydr. cab elevation, straight boom 19', stick with tipping kinematics 13'1", quick coupler SWA 48 LIKUFIX and Woodcracker® C350.

Weight	66,300 lb
Pad width	24"
Ground pressure	on request

ft in	Undercarriage	10 ft		15 ft		20 ft		25 ft		30 ft		35 ft		40 ft		45 ft		50 ft		ft in		
35	LC			16,9*	16,9*															15,5*	15,5*	15' 8"
30	LC			21,3*	21,3*	16,4	17,1*													12,0*	12,0*	22'10"
25	LC			21,0*	21,0*	16,6	17,8*	11,4	15,6*											9,7	10,6*	27' 2"
20	LC			21,6*	21,6*	16,4	18,1*	11,3	15,5*	8,2	10,6*									8,1	10,0*	30' 2"
15	LC			23,7*	23,7*	15,8	19,0*	11,1	15,7*	8,2	12,6									7,2	9,8*	32'
10	LC	40,1*	40,1*	23,5	26,6*	15,1	20,1*	10,7	16,1*	8,0	12,4									6,8	9,9*	33'
5	LC	14,3*	14,3*	21,7	28,5*	14,2	20,7*	10,2	16,0*	7,8	12,2									6,6	9,6*	33' 2"
0	LC	10,6*	10,6*	20,5	27,4*	13,6	19,9*	9,9	15,0*	7,6	11,0*									6,7	8,2*	32' 8"
-5	LC	13,8*	13,8*	20,1	23,1*	13,3	17,2*	9,7	12,7*											7,6	8,2*	30'

Height Can be slewed through 360° In longitudinal position of undercarriage Max. reach \* Limited by hydr. capacity

The lift capacities on the stick end without attachment are stated in lb x 1,000 and can be slewed through 360° on a firm, level supporting surface. Capacities are valid for 24" wide triple grouser pads. Indicated loads based on the ISO 10567 standard and do not exceed 75% of tipping or 87% of hydraulic capacity. The lift capacity of the unit is limited by its stability, the lifting capability of the hydraulic elements, or the maximum permissible lifting capacity of the load hook.

# LH 30 C LC – Equipment GSV12

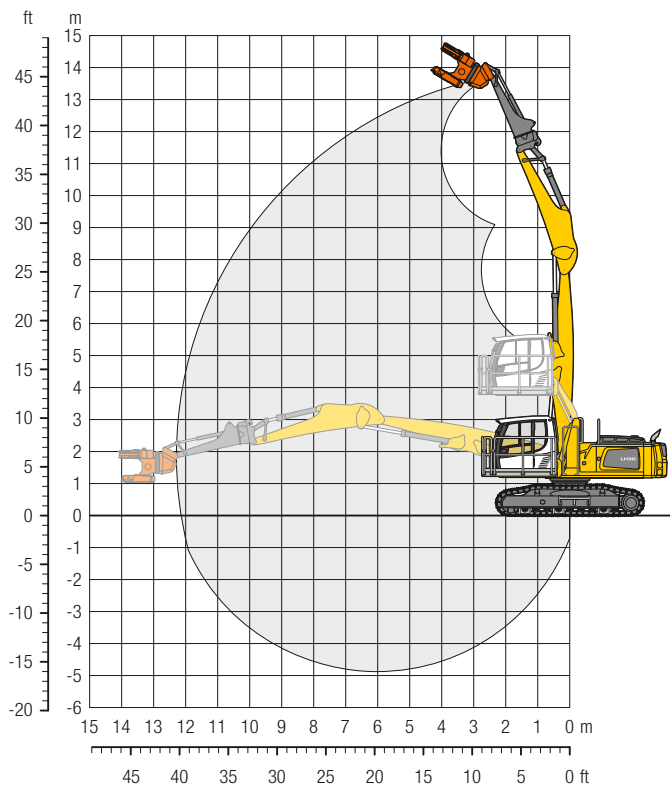

## Operating Weight and Ground Pressure

The operating weight includes the basic machine with hydr. cab elevation, straight boom 19', stick with tipping kinematics 13'1", quick coupler SWA 48 LIKUFIX, stick extension 7'5" and Woodcracker® C250.

Weight	65,900 lb
Pad width	24"
Ground pressure	on request

ft in	Undercarriage	10 ft		15 ft		20 ft		25 ft		30 ft		35 ft		40 ft		45 ft		50 ft		ft in		
		Can be slewed through 360°	In longitudinal position of undercarriage	Can be slewed through 360°	In longitudinal position of undercarriage	Can be slewed through 360°	In longitudinal position of undercarriage	Can be slewed through 360°	In longitudinal position of undercarriage	Can be slewed through 360°	In longitudinal position of undercarriage	Can be slewed through 360°	In longitudinal position of undercarriage	Can be slewed through 360°	In longitudinal position of undercarriage	Can be slewed through 360°	In longitudinal position of undercarriage	Can be slewed through 360°	In longitudinal position of undercarriage	Can be slewed through 360°	In longitudinal position of undercarriage	
55	LC																					
50	LC																					
45	LC																					
40	LC					11,7*	11,7*												10,2*	10,2*	21'	
35	LC					14,4*	14,4*	11,4*	11,4*										8,0*	8,0*	27' 8"	
30	LC							12,3	13,1*	8,7	10,2*								7,0*	7,0*	32' 2"	
25	LC							12,4	12,8*	8,9	11,7*	6,4	7,3*						6,2	6,4*	35' 5"	
20	LC							12,3	12,9*	8,8	11,7*	6,5	10,1						5,4	6,1*	37' 8"	
15	LC					14,8*	14,8*	11,9	13,5*	8,6	11,9*	6,4	10,0						5,0	5,9*	39' 2"	
10	LC					16,4	16,9*	11,3	14,3*	8,2	12,2*	6,2	9,8	4,7	6,0*				4,7	5,9*	40'	
5	LC	12,4*	12,4*	22,0*	22,0*	15,2	18,7*	10,6	15,1*	7,8	12,3	6,0	9,6	4,6	6,7*				4,6	6,1*	40' 2"	
0	LC	27,7*	27,7*	21,6	27,2*	14,0	19,8*	9,9	15,4*	7,4	11,9	5,7	9,3						4,6	6,1*	39' 8"	
- 5	LC	13,3*	13,3*	19,9	27,1*	13,0	19,5*	9,4	14,8*	7,1	11,5*	5,6	8,4*						4,9	5,4*	38' 4"	
-10	LC	14,2*	14,2*	19,0	23,9*	12,5	17,5*	9,1	13,1*	6,9	9,6*								5,7	6,2*	34' 7"	
-15	LC			17,9*	17,9*	12,3	13,3*	9,0	9,6*										8,4	8,8*	26' 2"	
-20	LC																					
-25	LC																					

**Height**
**Can be slewed through 360°**
**In longitudinal position of undercarriage**
**Max. reach**
**\* Limited by hydr. capacity**

The lift capacities on the end of the stick extension without attachment are stated in lb x 1,000 and can be slewed through 360° on a firm, level supporting surface. Capacities are valid for 24" wide triple grouser pads. Indicated loads based on the ISO 10567 standard and do not exceed 75% of tipping or 87% of hydraulic capacity. The lift capacity of the unit is limited by its stability, the lifting capability of the hydraulic elements, or the maximum permissible lifting capacity of the load hook.

# LH 30 C LC – Equipment GTS16

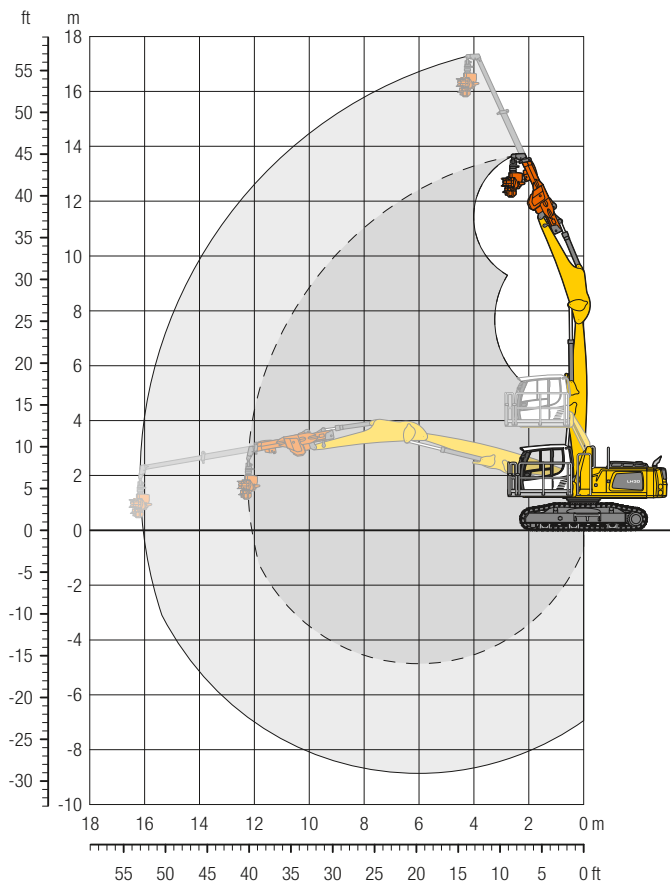

## Operating Weight and Ground Pressure

The operating weight includes the basic machine with hydr. cab elevation, straight boom 19', stick with tipping kinematics 13'1", quick coupler SWA 48 LIKUFIX, telescope stage T 4000 with 13'1" and Woodcracker® CS510 crane.

Weight	65,800 lb
Pad width	24"
Ground pressure	on request

ft in	Undercarriage	10 ft		15 ft		20 ft		25 ft		30 ft		35 ft		40 ft		45 ft		50 ft		ft in				
		Can be slewed through 360°	In longitudinal position of undercarriage	Can be slewed through 360°	In longitudinal position of undercarriage	Can be slewed through 360°	In longitudinal position of undercarriage	Can be slewed through 360°	In longitudinal position of undercarriage	Can be slewed through 360°	In longitudinal position of undercarriage	Can be slewed through 360°	In longitudinal position of undercarriage	Can be slewed through 360°	In longitudinal position of undercarriage	Can be slewed through 360°	In longitudinal position of undercarriage	Can be slewed through 360°	In longitudinal position of undercarriage	Can be slewed through 360°	In longitudinal position of undercarriage			
55	LC																				8,6*	8,6*	19' 4"	
50	LC							8,6*	8,6*													5,8*	5,8*	29' 2"
45	LC									8,1*	8,1*	5,4*	5,4*									4,7*	4,7*	35' 8"
40	LC											7,4*	7,4*	4,7*	4,7*							4,1*	4,1*	40' 7"
35	LC											8,1*	8,1*	6,2	6,6*							3,7*	3,7*	44' 4"
30	LC											7,9*	7,9*	6,4	7,4*	4,7	5,4*					3,5*	3,5*	47' 4"
25	LC											7,8*	7,8*	6,4	7,7*	4,8	6,5*					3,3*	3,3*	49' 6"
20	LC											7,8*	7,8*	6,4	7,7*	4,8	7,1*	3,6	4,4*	3,2*	3,2*	3,2*	3,2*	51' 2"
15	LC											8,1*	8,1*	6,2	7,8*	4,7	7,3*	3,5	5,3*	3,1	3,1*	3,1*	3,1*	52' 4"
10	LC											7,9	8,6*	6,0	8,1*	4,5	7,2	3,5	5,8	2,9	3,1*	3,1*	3,1*	52' 11"
5	LC								9,0*	9,0*	7,5	9,1*	5,6	8,3*	4,3	7,0	3,3	5,6	2,9	3,2*	2,9	3,2*	53'	
0	LC							8,6*	8,6*	9,3	10,8*	6,9	9,6*	5,3	8,4	4,1	6,7	3,2	5,5	2,9	3,2*	2,9	3,2*	52' 8"
-5	LC					9,5*	9,5*	11,6	13,0*	8,5	11,6*	6,4	10,0*	4,9	8,0	3,9	6,5	3,1	5,3*	2,9	3,4*	2,9	3,4*	51' 10"
-10	LC	29,6*	29,6*	22,9	24,0*	14,7	18,5*	10,3	14,7*	7,7	12,0*	5,9	9,6	4,6	7,7	3,7	6,3	3,1	3,9*	3,0	3,4*	3,0	3,4*	50' 6"
-15	LC	22,3*	22,3*	19,9	26,5*	13,0	19,2*	9,4	14,8*	7,1	11,6	5,5	9,1	4,4	7,4	3,6	5,3*							47' 6"
-20	LC	17,0*	17,0*	18,3	25,0*	12,0	18,1*	8,7	13,8*	6,7	10,8*	5,3	8,3*	4,3	5,9*									43'
-25	LC	17,1*	17,1*	17,6	20,8*	11,5	15,2*	8,4	11,4*	6,5	8,5*	5,2	5,9*											36'

Height Can be slewed through 360° In longitudinal position of undercarriage Max. reach \* Limited by hydr. capacity

The lift capacities on the end of the extended telescope stage without attachment are stated in lb x 1,000 and can be slewed through 360° on a firm, level supporting surface. The maximum lift capacities of the telescopic stage from Westtech have to be considered separately ([www.westtech.at](http://www.westtech.at)). Capacities are valid for 24" wide triple grouser pads. Indicated loads based on the ISO 10567 standard and do not exceed 75% of tipping or 87% of hydraulic capacity. The lift capacity of the unit is limited by its stability, the lifting capability of the hydraulic elements, or the maximum permissible lifting capacity of the load hook.





# Equipment

 Undercarriage	22 M	26 M	30 M	30 C
Trailer coupling			+	
Track pads, variants				+
Individual control outriggers	+	+	+	
Shuttle axle lock, automatic	•	•	•	
Outrigger monitoring system	+	+	+	
Dozer blade	+	+	+	
Tires, variants	+	+	+	
Protection for travel drive	+	+	+	
Protection for piston rods, outriggers	+	+	+	
Two storage compartments	•	•	•	
Undercarriage, variants	+	+		+

 Upper-carriage	22 M	26 M	30 M	30 C
Upper-carriage right side light, 1 piece, LED	•	•	•	•
Upper-carriage rear light, 2 pieces, LED	+	+	+	+
Heavy counterweight			+	
Tank refilling pump fuel	+	+	+	+
Railing on upper-carriage			+	+
Generator	+	+	+	+
Main battery switch for electrical system	•	•	•	•
Amber beacon, at upper-carriage, LED double flash	+	+	+	+
Protection for headlights	+	+	+	+
Protection for rear lights	+	+	+	+
Tool equipment, extended	+	+	+	+

 Hydraulic System	22 M	26 M	30 M	30 C
Electronic pump regulation	•	•	•	•
Liebherr hydraulic oil from -4 °F to +104 °F	•	•	•	•
Liebherr hydraulic oil, biologically degradable	+	+	+	+
Magnetic rod in hydraulic tank	•	•	•	•
Bypass filter	+	+	+	+
Preheating hydraulic oil	+	+	+	+

 Engine	22 M	26 M	30 M	30 C
Fuel anti-theft device	+	+	+	+
Air pre-filter with dust discharge	+	+	+	+
Automatic engine shut-down (time adjustable)	+	+	+	+
Preheating fuel	+	+	+	+
Preheating coolant			+	+
Preheating coolant *	+	+		
Preheating engine oil *	+	+	+	+

 Cooling System	22 M	26 M	30 M	30 C
Radiator, large-mesh, for dust-intensive operation	•	•	•	•
Reversible fan drive	+	+	+	+
Protective grid (close-mesh) in front of cooler intake, extendible	•	•		
Protective grid in front of cooler intake			•	•

 Operator's Cab	22 M	26 M	30 M	30 C
Stabilizer, control lever, left console	+	+	+	
Stabilizer, proportional control on left joystick	•	•	•	
Cab lights rear, halogen			+	+
Cab lights rear, LED			+	+
Cab lights front, halogen	+	+	+	+
Cab lights front, halogen (under rain cover)	•	•	•	•
Cab lights front, LED	+	+	+	+
Cab lights front, LED (under rain cover)	+	+	+	+
Armrest adjustable	•	•	•	•
Slewing gear brake Comfort, button on the left or right joystick	+	+	+	+
Operator's seat Comfort	•	•	•	•
Operator's seat Premium	+	+	+	+
Driving alarm				
(acoustic signal is emitted during travel, can be switched ON/OFF)	+	+	+	+
Fire extinguisher	+	+	+	+
Footrest	+	+	+	+
Horn, button on left joystick	•	•	•	•
Joystick steering (max. 7.5 mph)	•	•	•	•
Joystick and wheel steering (slim version)	+	+	+	
Cab elevation, hydraulic (LHC)	•	•	•	•
Cab elevation, hydraulic with tilt function (LHC)	+	+	+	+
Cab elevation, rigid (LFC)	+	+	+	+
Automatic air conditioning	•	•	•	•
Wheel steering (slim version)	+	+	+	
LiDAT, vehicle fleet management	•	•	•	•
Proportional control	•	•	•	•
Radio Comfort, control via display with handsfree set	+	+	+	+
Preparation for radio installation	•	•	•	•
Back-up alarm				
(acoustic signal is emitted traveling backward, can not be switched off)	+	+	+	
Amber beacon, on cabin, LED double flash	+	+	+	+
Windows made from impact-resistant laminated safety glass	+	+	+	+
Windscreen wiper, roof	+	+	+	+
Windshield wiper, entire windscreen	•	•	•	•
FOPS top guard	+	+	+	+
FGPS front guard, tiltable	+	+	+	+
Sun visor	+	+	+	+
Left control console, folding	•	•	•	•

 Equipment	22 M	26 M	30 M	30 C
Boom lights, 2 pieces, halogen	•	•	•	•
Boom lights, 2 pieces, LED	+	+	+	+
Stick lights, 2 pieces, halogen	•	•	•	•
Stick lights, 2 pieces, LED	+	+	+	+
Filter system for attachment	+	+	+	+
Height limitation and stick shutoff, electronically	+	+	+	+
Boom cylinder cushioning	+	+	+	+
Stick camera (with separate monitor), bottom side, with protection	+	+	+	+
Load holding valve tipping cylinder	+	+	+	+
Liebherr multi coupling system	+	+	+	+
Liebherr quick coupler, hydraulic	+	+	+	+
Pipe fracture safety valves hoist cylinders	•	•	•	•
Pipe fracture safety valves stick cylinders	•	•	•	•
Quick coupling system LIKUFIX	+	+	+	+
Quick coupling system MH 40B		+	+	+
Protection for piston rod, tipping cylinder	+	+	+	+
Protection for piston rods, hoist cylinder	+	+	+	+
Protection for piston rods, stick cylinder	+	+	+	+
Overload warning device	+	+	+	+

 Complete Machine	22 M	26 M	30 M	30 C
<b>Packages</b>				
Tree care and the wood industry	+	+	+	+
Recycling package	+	+		
<b>Lubrication</b>				
Lubrication undercarriage, manually – decentralized (grease points)	•	•	•	
Lubrication undercarriage, manually – centralized (one grease point)	+	+	+	
Central lubrication system for uppercarriage and equipment, automatically	•	•	•	•
Central lubrication system for undercarriage, automatically	+	+	+	
Centralized lubrication extended for attachment	+	+	+	+
<b>Special coating</b>				
Special coating, variants	+	+	+	+
<b>Monitoring</b>				
Rear view monitoring with camera	•	•	•	•
Side view monitoring with camera	•	•	•	•

• = Standard, + = Option  
 \* = country-dependent

Options and/or special equipments, supplied by vendors other than Liebherr, are only to be installed with the knowledge and approval of Liebherr in order to retain warranty.

# Attachments

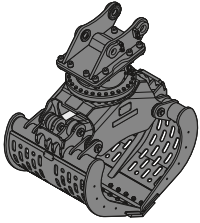

		per-forated			ribbed			closed			per-forated		
		ft in	ribbed	closed	per-forated	ribbed	closed	per-forated	ribbed	closed	per-forated		
<b>Grab model SG 25B</b>													
Width of shells	ft in	2'7"	2'7"	2'7"	3'3"	3'3"	3'3"	3'11"	3'11"	3'11"	4'7"		
Capacity	yd <sup>3</sup>	0.72	0.65	0.72	0.98	0.85	0.98	1.18	1.05	1.18	1.44		
Max. closing force	lbf	13,489	13,489	13,489	13,489	13,489	13,489	13,489	13,489	13,489	13,489		
Weight incl. adapter plate SWA	lb	2,735	2,835	2,780	2,875	3,020	2,930	3,020	3,210	3,085	3,165		

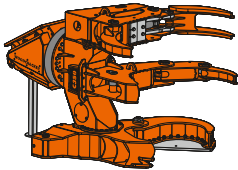

		C250		C350	
		in	ft in	in	ft in
Cutting diameter soft wood	in	13.0"		15.7"	
Cutting diameter hard wood	in	11"		13.8"	
Grab opening	ft in	3'1"		4'8"	
Diameter of shears	in	17.7"		27.6"	
Deadweight (basic – fully equipped)	lb	1,280 – 2,140		2,535 – 3,570	
Accumulator		optional		optional with quick coupler	

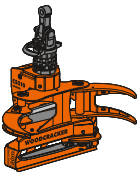

<b>Woodcracker® CS510 crane</b>		
Cutting diameter	in	21.3"
Grab opening	ft in	4'2"
Deadweight (basic – fully equipped)	lb	795 – 970
Chain lubrication saw		oil

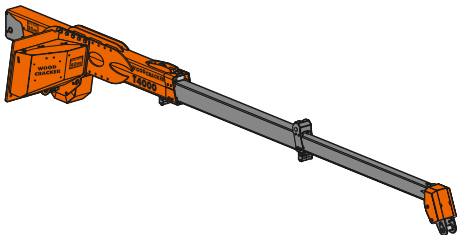

<b>Woodcracker® Telescope Stage T 400</b>		
Telescope stroke	ft in	13'1"
Telescope version		double
Deadweight	lb	1,455 – 1,545
Stroke torque ex excavator kinematics	lbf ft	67,856
Stroke force (fully extended)	lb	3,415
Telescope hose guide		inside

## WARNING

This product can expose you to chemicals including lead and lead compounds, which are known to the State of California to cause cancer and birth defects or other reproductive harm.  
For more information go to [www.P65warnings.ca.gov](http://www.P65warnings.ca.gov).

## WARNING

Breathing diesel engine exhaust exposes you to chemicals known to the State of California to cause cancer and birth defects or other reproductive harm.

- ▶ Always start and operate the engine in a well-ventilated area.
- ▶ If in an enclosed area, vent the exhaust to the outside.
- ▶ Do not modify or tamper with exhaust system.
- ▶ Do not idle the engine except as necessary.

For more information go to [www.P65warnings.ca.gov/diesel](http://www.P65warnings.ca.gov/diesel).

For further information on Westtech tools please refer to [www.westtech.at](http://www.westtech.at)