

HT100V CTL

Powered By Hyundai Tier 4 Final Engine

Net Power

69.7 hp (52kW) / 2,400 rpm

Standard Bucket

0.44 m³ (0.58 yd³)

Rated Operating Capacity

4,425 kg (9,755 lb)

ENGINE	
Make	Hyundai / 4HTI4
Emissions certification	EPA Tier 4-Final
Type	Diesel
Gross Power (SAE J1995)	73.6 hp (54.9 kW) / 2,400 rpm
Net Power (SAE J1349)	69.7 hp (52 kW) / 2,400 rpm
Max. Power	73.6 hp (54.9 kW) / 2,400 rpm
Peak Gross Torque	274 N·m (202 lbf·ft) / 1,500rpm
Displacement	2,435 cc (148.6 cu in)
Number of Cylinders	4 cylinders
Bore	87 mm (3.4")
Stroke	102.4 mm (4.0")

OPERATING SPECIFICATION	
Operating Weight	4,425 kg (9,755 lb)
Breakout Force (Bucket)	2,814 kgf (6,204 lbf)
Breakout Force (Lift Arm)	2,162 kgf (4,766 lbf)
Traction Force	2,940 kgf (6,482 lbf)
Lift Arm Path	Vertical
Control	ISO Pilot

RATED OPERATING CAPACITY	
35% Tipping Load	1,043 kg (2,300 lb)
Tipping Load	2,980 kg (6,570 lb)

BUCKET CAPACITY	
Heaped	0.44 m ³ (0.58 yd ³)
Struck	0.35 m ³ (0.46 yd ³)

CABIN	
ROPS	ISO 3471
FOPS	ISO 3449

UNDERCARRIAGE	
Track Width	400 mm (1' 4")
Ground Pressure	38.5 kPa (5.6 psi)
No. Of Track Roller (Per Side)	4
Track Ground Contact Area	0.574 m ² (0.686 yd ²)
Travel Speed (1-Speed)	N/A
Travel Speed (2-Speed) Low	7.5 km/h (4.7 mph)
Travel Speed (2-Speed) High	11.5 km/h (7.1 mph)
Track Tension Type	Grease
Track Suspension	N/A

HYDRAULIC SYSTEM	
HYDRAULIC FLOW - BASIC	
Hydraulic Pressure	230 bar (3,335 psi)
Hydraulic Flow	82.9 lpm (21.9 gpm)

CAPACITY	
Fuel tank	100 liters (26.4 US gal)
Engine oil (Filter included)	9 liters (2.4 US gal)
Engine coolant (Only Engine)	4.2 liters (1.1 US gal)
Engine coolant (Radiator Included)	10.4 liters (2.7 US gal)
Hydraulic tank	38 liters (10 US gal)

SOUND	
Inside Cab (ISO 6396:2008)	83 dB
Outside Cab	103 dB

*No DEF Fluid required

EQUIPMENT

STANDARD EQUIPMENT	
<ul style="list-style-type: none"> Enclosed Cab (ROPS/FOPS) Mechanical Suspension Seat 3" Retractable Seat Belt 12V Electric Outlet / USB Outlet Air Conditioner & Heater Horn / Backup Alarm Driving Lamp (Rear 2) Working Lamp (Front 2) Dial and Foot Throttle 	<ul style="list-style-type: none"> Hydraulic Quick Coupler Rubber Wide Track 15.7"(400mm) Boom Float Function Dual Air-Cleaner Elements Rearview Camera Bucket Self-leveling (Up Only) Rearview Mirror Two-Speed Travel Multifunction Lever Interior Cab Light/Courtesy Light

OPTIONAL EQUIPMENT	
<ul style="list-style-type: none"> 2" Retractable Seat Belt* Side Mirrors License Lamp Beacon Lamp Driving Lamp (Front 2/Rear 2) Working Lamp (Front 2/Rear 2) Mechanical Quick Coupler* Additional Counterweight 	<ul style="list-style-type: none"> Mech. Suspension Seat Polycarbonate Front Door* Bluetooth/USB Radio Telematics (Hi-MATE) 14-pin Coupler for Attachments Fire Extinguisher Tool Kit ... and much more.

* Factory Option

SPECIFICATIONS HT100V

Powered By Hyundai Tier 4 Final Engine

DIMENSIONS

All dimensions are approximate.

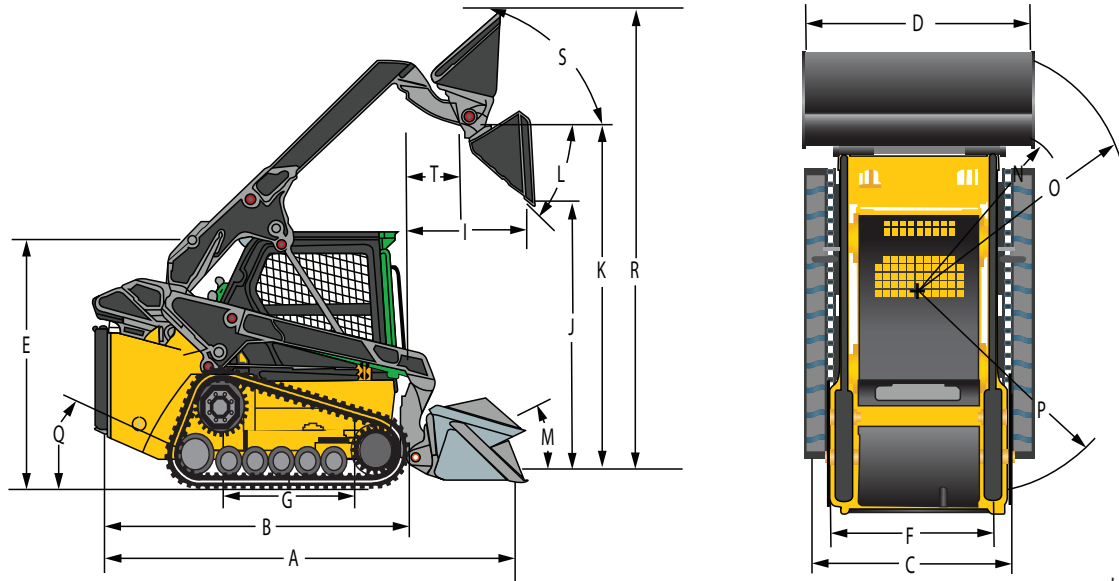

Unit : mm (fin)

DIMENSIONS		HT100V
A	Length w/bucket on ground	3,654 (12' 0")
B	Length w/o bucket	2,795 (9' 2")
C	Vehicle width over tire	1,794 (5' 11")
D	Width with bucket	1,890 (6' 3")
E	Height to top of cab	2,078 (6' 10")
F	Track tread	1,394 (4' 7")
G	Wheelbase	1,435 (4' 8")
H	Ground clearance	230 (0' 9")
I	Reach at max. lift and dump	916 (3' 0")
J	Height at max. lift and dump	2,468 (8' 1")
K	Hinge pin height at max. lift	3,211 (10' 6")
L	Max. dump angle	44.5°
M	Rollback angle on ground	29°
N	Turning radius from center - coupler	1,672 (5' 6")
O	Turning radius from center - bucket	2,289 (7' 6")
P	Turning radius from center - machine rear	1,720 (5' 8")
Q	Rear departure angle	25°
R	Max. overall height	4,060 (13' 4")
S	Rack back angle at max height	87.2°
T	Bucket pin reach at maximum lift	442 (1' 5")



www.hceamericas.com
6100 Atlantic Blvd., Norcross, GA 30071
TEL (678) 823-7777 FAX (678) 823-7778

Printed in U.S.A.

PLEASE CONTACT

1128-CTL-SP 12/2022v8